



PARTS CATALOGUE

1 AUGUST 2021

Version 9



COMPLETE SUSPENSION SOLUTIONS



**2019
WINNER**

Excellence in Export
Parramatta Chamber of Commerce



**2019
FINALIST**

NSW Defence Industry Award



**2019
FINALIST**

Excellence in Business
Parramatta Chamber of Commerce



**2019
FINALIST**

Excellence in Export

WWW.TOUGHDOG.COM.AU

Unless specified otherwise, all listings in this catalogue are for 4WD (Four Wheel Drive) vehicles only.

WARRANTY	5	JACKAROO, MONTEREY	
RECOVERY GEAR	24	UBS25, 26, 69, 73	65
GVM UPGRADES		RODEO	
FORD - RANGER PXIII	27	KB4, KBD4	66
ISUZU - D-MAX	28	TFS17, 54, 55, TFS25, 77	67
MAZDA -BT-50	29	RODEO & COLORADO - RA-RC	68
TOYOTA		COLORADO - RG, MMU142, GM1700	
HILUX 4WD & 2WD	30	07/2012-06/2016	70
LANDCRUISER 78 T CARRIER	31	06/2016 on.....	72
79 SINGLE/DUAL CAB	32	COLORADO 7 / TRAILBLAZER	74
200 SERIES - GX ONLY	33	HYUNDAI	
200 SERIES - GXL, VX, SAHARA	34	TERRACAN - HP	75
ASIA MOTORS		ISUZU	
ROCSTA	36	D-MAX	
DAEWOO		MY09-MY11	76
MUSSO	37	TFS85, V-CROSS, MY12	
DAIHATSU		05/2012-04/2016	78
F10, F20, F50, F60 Inc. scat	38	04/2016-08/2020	80
F25, F55, F65	39	08/2020 on.....	82
FEROZA - CX12, F300	40	MU-X - MY13 ON	83
FEROZA II - F310	41	JEEP	
ROCKY		CHEROKEE - XJ LIMITED, SPORT	84
F70, F75 / F80, F85 / F77, F87	42	GRAND CHEROKEE	
F73, F78 (COIL SPRINGS)	43	ZG WG, WJ.....	85
FORD		WV2	86
EVEREST		WRANGLER	
UA1	44	TJ.....	87
UA2.....	46	JK	88
EXPLORER - UN, UP, UQ	48	JL (EX RUBICON).....	89
BRONCO - THIRD GENERATION	49	GLADIATOR - JT	90
F250		LANDROVER	
2003-2006.....	50	80,88 SWB, 109 LWB - SERIES I, II, IIA & III	91
2016-2020.....	51	DEFENDER	
COURIER - PC, PD, PE, PG & PH	52	110 COUNTY	92
RANGER		90 SERIES	93
PJ & PK, 2.5L & 3.0L.....	53	110, 130 SERIES	94
PX & PXII	54	DISCOVERY	
PXIII	56	SERIES I	95
PXIII RAPTOR ONLY	58	SERIES II & III.....	96
GREAT WALL		RANGE ROVER	
UTE (WINGLE, SAILOR)	59	CLASSIC - NON AIR SUSPENSION	97
HOVER, SAFE, HAVAL	60	WITH AIR SUSPENSION.....	98
STEED	61	LADA	
HOLDEN		NIVA	99
FRONTERA - MB & MX	62	LDV	
JACKAROO, ISUZU TROOPER		T60.....	100
UBS13, 16, 52, 52I	63	MAZDA	
UBS16, 17, 52, 55	64	B2500, B2600, B4000	
		PC, PD, PE, PG, PH	101

TABLE OF CONTENTS



Unless specified otherwise, all listings in this catalogue are for 4WD (Four Wheel Drive) vehicles only.

BT-50		GQ CAB CHASSIS (COIL/COIL)	158
B2500, B3000	102	Y62 (NON HYDRAULIC ONLY).....	160
UP, UR	104	TERRANO II - R20.....	162
TF.....	106	RAM	
MERCEDES-BENZ		1500 DS SERIES	163
X-CLASS UTE	108	2500 SERIES	164
MITSUBISHI		SSANGYONG	
CHALLENGER		MUSO (INC SPORT UTE)	165
PA (LEAF REAR).....	109	SUZUKI	
PA II (COIL REAR)	110	JIMNY	
CHALLENGER/PAJERO SPORT		SN413 (JB33, 43, 48)	166
PB & PC.....	111	JB74	168
L200 4WD - MA, MB, MC, MD	112	SIERRA - LEAF SPRING.....	170
L300 4WD - SC, SD, SE, SF, SG, SH.....	113	VITARA - INC GRAND VITARA & XL7	172
PAJERO/MONTERO		TOYOTA	
LEAF REAR	114	FORTUNER	
COIL REAR.....	115	2004-12/2015	174
NM-NX.....	116	2015 on.....	176
PAJERO SPORT - QE	118	4RUNNER	
TRITON		IFS/LEAF REAR.....	178
ME-MK	119	IFS/COIL REAR.....	180
ML-MN	120	HILUX	
MQ.....	122	LEAF/LEAF	182
MR	124	TORSION BAR FRONT	
NISSAN		10/1988-1997	184
NAVARA		10/1997-005	186
D21, D22.....	126	KUN26, GGN25R (COIL/LEAF)	188
D40 - 2.5L, 4.0L.....	128	GUN125R, 126R, GGN125R (COIL/LEAF)....	190
D40, 3.0L STX-550 V6.....	130	2WD - HILUX WORKMATE	192
NP300		LANDCRUISER	
COIL REAR.....	132	40, 42 SERIES	194
COIL REAR (S5)	133	45, 47 SERIES	196
LEAF REAR	134	60, 61, 62 SERIES	198
PATHFINDER		70 SERIES BUNDERA.....	199
WNYD21, WHYD21	135	71, 74 SERIES	201
R50 (S I, II, III).....	136	70, 73, 74 SERIES	202
R51 2.5L, 4.0L	137	75 SERIES.....	204
R51 3.0L V6	138	76 SERIES WAGON	206
PATROL		77 SERIES	208
MQ, MK	140	78 SERIES (COIL SPRINGS).....	210
GQ (Y60) 2" LIFT	142	78, 79 SERIES (SINGLE CAB).....	212
GU (Y61) 2" LIFT	144	78, 79 SERIES (DUAL CAB).....	214
GQ, GU		80 & 100 SERIES	
(Y60, Y61) 3" LIFT	146	2"	216
(Y60, Y61) 4" LIFT	148	3"	218
(Y60, Y61) 5" LIFT	150	4"	220
(Y60, Y61) 6" LIFT	152	5"	222
GQ CAB CHASSIS (LEAF/LEAF)	154	6"	224
GQ CAB CHASSIS (COIL/LEAF).....	156	100 SERIES (IFS).....	226

All prices exclude freight. Include only permanent accessories & weights when selecting springs. Towing weight is not included.



Unless specified otherwise, all listings in this catalogue are for 4WD (Four Wheel Drive) vehicles only.

200 SERIES	228
PRADO	
95 SERIES	230
120 SERIES	232
150 SERIES	234
FJ CRUISER.....	236
RAV4 - SXA, 10, 11	238
TUNDRA - UCK, UPK, USK 55, 56	239
UAZ	
UAZ, HUNTER, PATRIOT	240
VOLKSWAGEN	
AMAROK	241
ROCK DOG.....	242
FITTING SHEET.....	243
CLAIMS FORM.....	244
DISCLAIMER FORM	245
PURCHASE ORDER FORM.....	246

LIMITED WARRANTY

TERMS & CONDITIONS



This warranty is provided by 4 Way Suspension Products Pty Ltd, of 14 Darling Street Marsden Park, NSW, 2765, Australia through its dealers and agents in the relevant territory.

Please note: All Warranty Claims are to be returned to the place of original purchase

Our goods come with guarantees that cannot be excluded under the Australian Consumer Law. You are entitled to a replacement or refund for a major failure and compensation for any other reasonably foreseeable loss or damage. You are also entitled to have the goods repaired or replaced if the goods fail to be of acceptable quality and the failure does not amount to a major failure.

The benefits under our limited warranty are in addition to other rights and remedies under applicable law in relation to the product. At 4 Way Suspension Products Pty Ltd, we want you to have complete confidence in each and every 4 Way product you own. That's why we back our products with a manufacturer's warranty.

ACCOUNTS

Account applications that are approved must comply with the following Term & Conditions

1. All export orders must be prepaid before shipment.
2. Credit terms are 30 days from the end of the trading month.
3. Credit will be suspended if payment is not made within the trading terms.
4. Unpaid accounts at 30 days will be placed on stop supply.
5. If no credit arrangement exists, all goods must be prepaid before leaving 4 Way Suspension premises.
6. If the applicant is a company, the Director's Guarantee must be completed by all relevant parties.

FREIGHT & INSURANCE

All prices are quoted Ex-Warehouse and do not include freight. Ownership of the goods passes to the buyer at the time they leave the 4 Way Suspension Premises, providing that payment has been made according to the applicable account terms. Unless specified otherwise, freight will be added to the total cost of goods using the Supplier's preferred freight company.

CREDIT & WARRANTY RETURNS

Goods for credit or exchange must be returned within fourteen (14) days of invoice date accompanied by a completed **Returns Form**. Goods returned for the purpose of warranty claim must also be accompanied by the returns form along with a copy of the customer invoice. Freight for returned goods can be arranged by the returning party or by 4 Way Suspension, but in both cases, the associated costs remain the responsibility of the returning party.

15% OF THE TOTAL VALUE OF THE RETURNED GOODS WILL BE CHARGED IN THE EVENT THAT REPACKAGING IS REQUIRED

WARRANTY EXCLUSIONS

1. Parts that have been incorrectly installed.
2. Struts that have been assembled with the use of any tool other than hand tools (no rattle guns or impact tools)
3. Load bearing strut bushes that have been tightened while hanging. Strut bushes must be tightened while the vehicle is on the ground supporting its own weight.
4. Interference between shock absorber and other suspension components.
5. Parts that have been involved in a motor vehicle accident or have been bent or have been physically damaged by impact of any kind.
6. Parts showing evidence of improper tightening of the mounting bolts causing parts to wear or bend.
7. Gripping tool marks (vice grips or multi grips) or any other tool made marks on the polished chrome section of the shock absorber shaft.
8. All parts subjected to abuse.
9. All parts used in racing or competition events of any description.
10. Fair wear & tear components (including bushings – warranted for 12 months from date of purchase as a component of the shock absorber)

11. Any special-order parts (in which case the warranty is limited to manufacturing defects)*

12. Parts fitted to vehicles weighing more than original GVM or the revised GVM specified by a Tough Dog GVM upgrade.

*Please Note: Any components built to a special order or specification outside the catalogue listings is covered by warranty limited to manufacturing defects. The manufacturer is unable to guarantee the suitability of components for an application for which has not been tested. Failure arising as a result of the application is excluded.

PROOF OF PURCHASE

A copy of proof of purchase by the retail customer must be attached to the claim including the kilometre reading at the time of fitment (if applicable). Each 4WD Suspension fitted must have a fitting sheet completed and kept on file by either the vehicle owner or the fitment centre performing the work. Failure to produce the fitting sheet may affect the warranty of the product. Warranty is limited to coverage of the original purchaser and is not transferrable with transfer of ownership of the vehicle.

WARRANTY PERIODS

Product	Recreational Wty	Commercial Wty
53mm Ralph & 45mm Adjustable	4 Year/unlimited km	3 Year/unlimited km
35mm Nitro Gas Shocks	3 Year/unlimited km	Not Applicable
Foam Cell & 40mm Adjustable	4 Year/unlimited km	3 Year/unlimited km
RTC/EXT/SV Dampers	4 Year/unlimited km	3 Year/unlimited km
Leaf Springs	4 Year/unlimited km	3 Year/unlimited km
Coil Springs (up to 2")	4 Year/unlimited km	3 Year/unlimited km
Coil Springs (above 2")	3 Year/unlimited km	3 Year/unlimited km
Upper Control Arms	4 Year/unlimited km	3 Year/unlimited km
AirAssist Products	4 Year/unlimited km	3 Year/unlimited km
GVM Upgrades	4 Year/unlimited km	3 Year/unlimited km
Recovery Equipment	3 Year material & manufacture	3 Year material & manufacture

SELF FIT (DIY) SUSPENSIONS

DIY suspension fitment does not affect the warranty application or term as long as the following conditions are adhered to:

1. A fitting sheet is completed prior to the suspension being fitted and filed for later reference.
2. The above fitment sheet accurately and clearly includes bottom of rim to wheel arch measurements for all four corners of the vehicle both before and after fitment, as well as at the 500km check service.
3. U-Bolts must be replaced at the time of fitment. U-Bolts are a 'stretch fit' item, and should not be torqued to tightness twice. Re-using U-Bolts puts the vehicle and occupants at risk

WARRANTY LIMITS

4 Way Suspension Products Pty Ltd provides this product warranty which is limited to the repair or replacement of defective or faulty parts and does not include any costs incurred in labour for the removal or re-fitment of parts or damage incurred as a result of the product's fitment.

All prices exclude freight. Include only permanent accessories & weights when selecting springs. Towing weight is not included.



MAKING TRACKS SINCE 1985

Tough Dog has been “making tracks across the world” since 1985, and have grown rapidly as a result of the excellent reputation their quality gear commands. Today, Tough Dog products are sought after the world over, and the distribution network spans 41 countries around the world.

With some of the harshest conditions right here in Australia to test out products, the gear that makes it to the market is a cut above the rest.

In 2018, Tough Dog took up residence in the new Headquarters in Marsden Park. Featuring dedicated spaces for Research & Development,

Design & Manufacture, and Bulk Production, the new home of Tough Dog marks the beginning of a new chapter in our international story. Our efforts in the export market were also recognised, with 3 runner-up positions and a win in the WSABE Excellence in Export category.

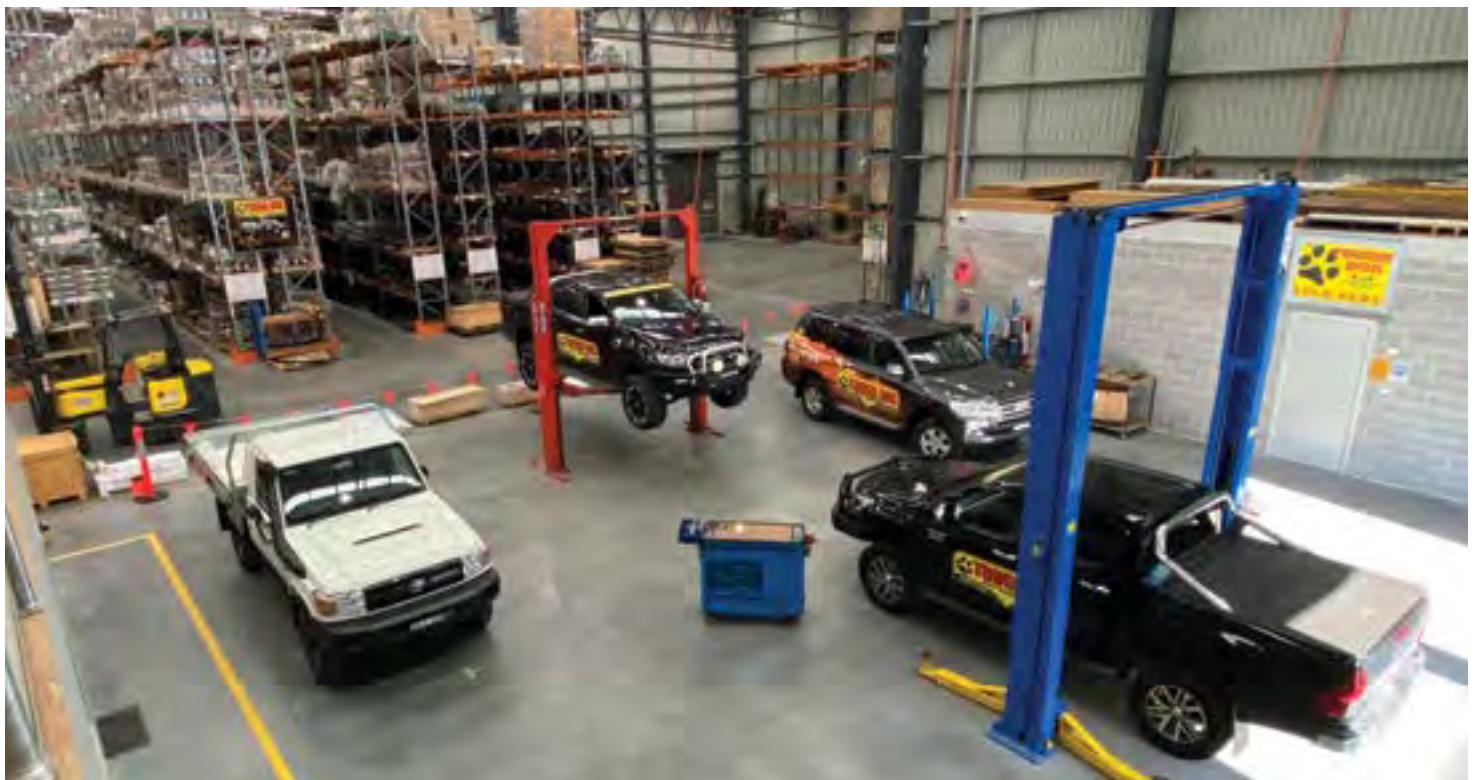

Fitting sheet (located page 243) must be completed when suspension fitted. Failure to comply may affect warranty.

JOIN THE PACK... ONLINE!

Finding the right Tough Dog suspension kit for any application has never been easier than with our online kit builder. Just choose the vehicle, accessories, and shock choice that you need, and the suitable kits will be displayed!

It could not be easier. If you're in Australia, you can even order your kit online, and collect it from your local authorised Tough Dog Dealer. Come & "Join The Pack" online today!



SELECT YOUR VEHICLE AND FRONT ACCESSORIES:

SELECT YOUR 4WD	FORD
MODEL	RANGER
YEAR/SERIES	PXIII RANGER
FRONT SETUP	STEEL BULLBAR



SELECT YOUR SHOCKS AND SPRINGS:



ADD OPTIONAL ACCESSORIES:

PINS & SHACKLES

UPPER CONTROL ARMS

'AIR ASSIST' AIR BAGS

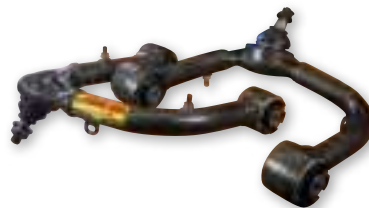

SELECT

SELECT

SELECT



FIND YOUR NEAREST DEALER:

ENTER YOUR POSTCODE

2765

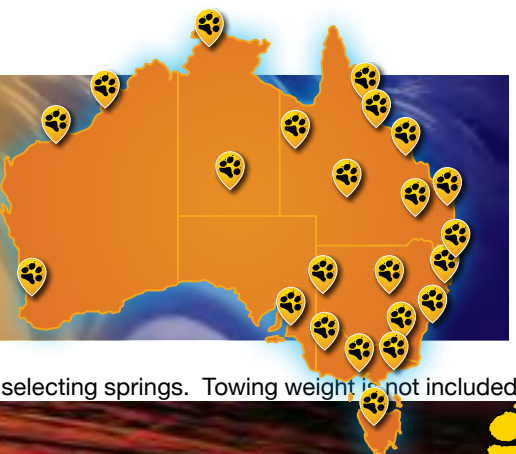

All prices exclude freight. Include only permanent accessories & weights when selecting springs. Towing weight is not included.

PERFORMANCE FROM THE INSIDE OUT

41mm FOAM CELL shock

- 🐾 Award Winning 'Best All-Round Performer'
- 🐾 41mm Bore Size*
- 🐾 60mm Outer Casing*
- 🐾 18mm Piston Rod
- 🐾 Reinforced Welded Mounting Points
- 🐾 4 Year Unlimited Kilometre Warranty (see catalogue for full warranty terms)

*Sizes may vary due to vehicle fitment

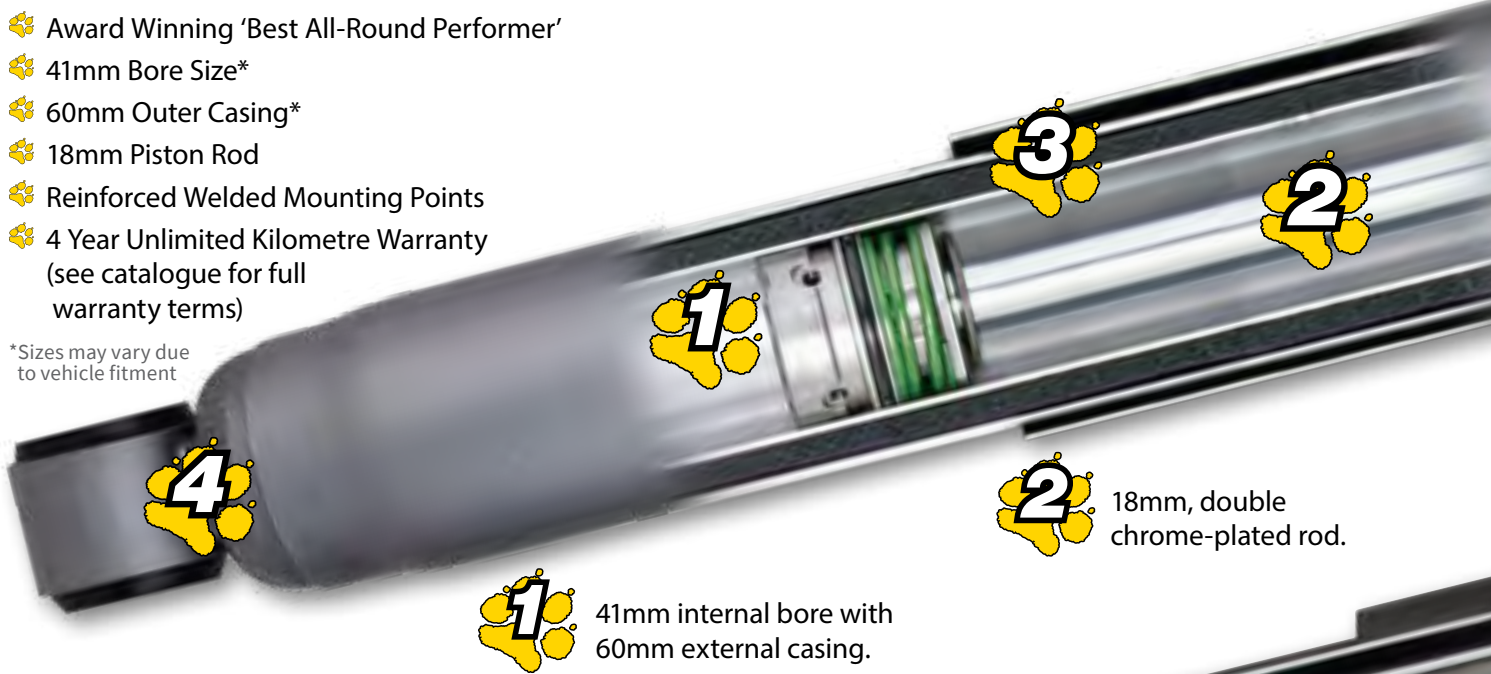

1 41mm internal bore with 60mm external casing.

2 18mm, double chrome-plated rod.

53mm RALPH shock

- 🐾 53mm Bore
- 🐾 70mm Outer Casing
- 🐾 22mm Piston Rod
- 🐾 Reinforced Welded Mounting Points
- 🐾 Huge Oil Reservoir
- 🐾 4 Year Unlimited Kilometre Warranty (see catalogue for full warranty terms)

*Sizes may vary due to vehicle fitment.

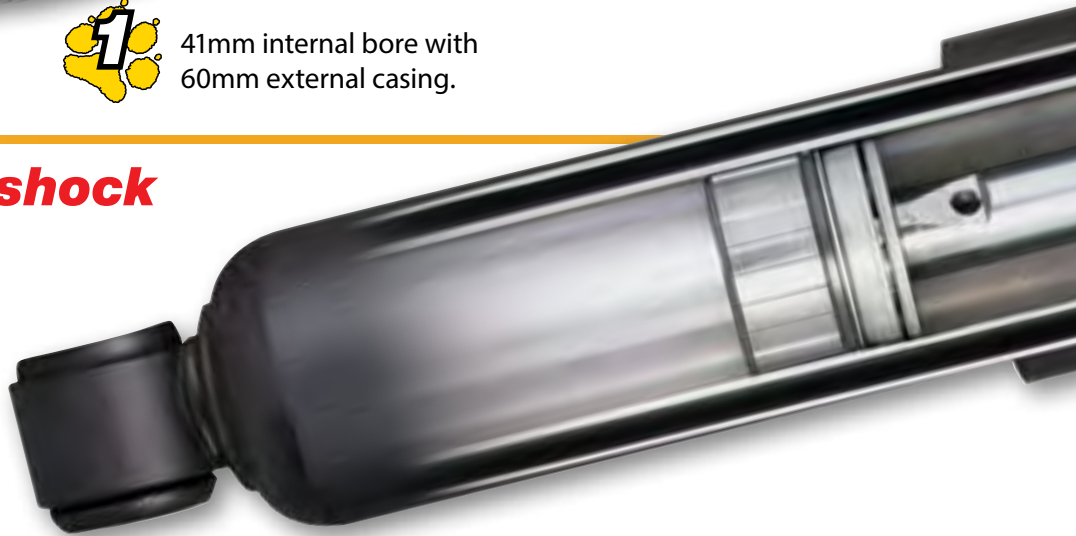

35mm NITRO GAS shock

- 🐾 35mm Bore
- 🐾 50mm Outer Casing
- 🐾 Medium Duty Use
- 🐾 Velocity Sensitive Valving
- 🐾 3 Year Unlimited Kilometre Warranty (see catalogue for full warranty terms)

*Sizes may vary due to vehicle fitment.

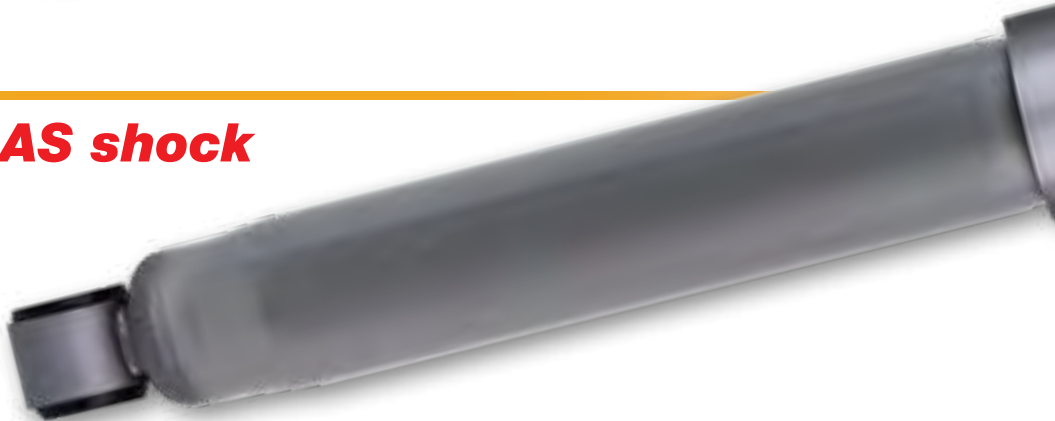

Fitting sheet (located page 243) must be completed when suspension fitted. Failure to comply may affect warranty.

BIG SHOCK, BIG PERFORMANCE



Double welded end fittings in all applications for maximum strength.



Micro-cellular foam insert that reduces shock fade.



COMPLETE STRUT ASSEMBLIES

Modern IFS vehicles use strut style suspension in the front axle, and the spring rate required can be more than 750lbs in some instances. This enormous pressure needs an industrial spring compressor to ensure correct assembly. Assembling the strut unit

prior to fitment to the vehicle is the most crucial part of any suspension fit out, and incorrect assembly can lead to premature suspension failure. Tough Dog offer their complete range of struts in complete assembly variants – at no extra cost!

All prices exclude freight. Include only permanent accessories & weights when selecting spring. Freight is not included.



45mm BIG BORE ADJUSTABLE shock

- 🌟 Huge 45mm Internal Bore with 70mm Outer Casing for Maximum Oil Capacity
- 🌟 Equipped with our Micro-Cellular Foam Insert that Reduces Shock Fade
- 🌟 9 Stage External Adjustment – Comprehensive Ride Control!
- 🌟 22mm, Chrome-Plated Piston Rod
- 🌟 External, On-Shaft Bump Stop on Most Part Numbers
- 🌟 4 Year Warranty (see catalogue for full warranty terms)

*Sizes may vary due to vehicle fitment.

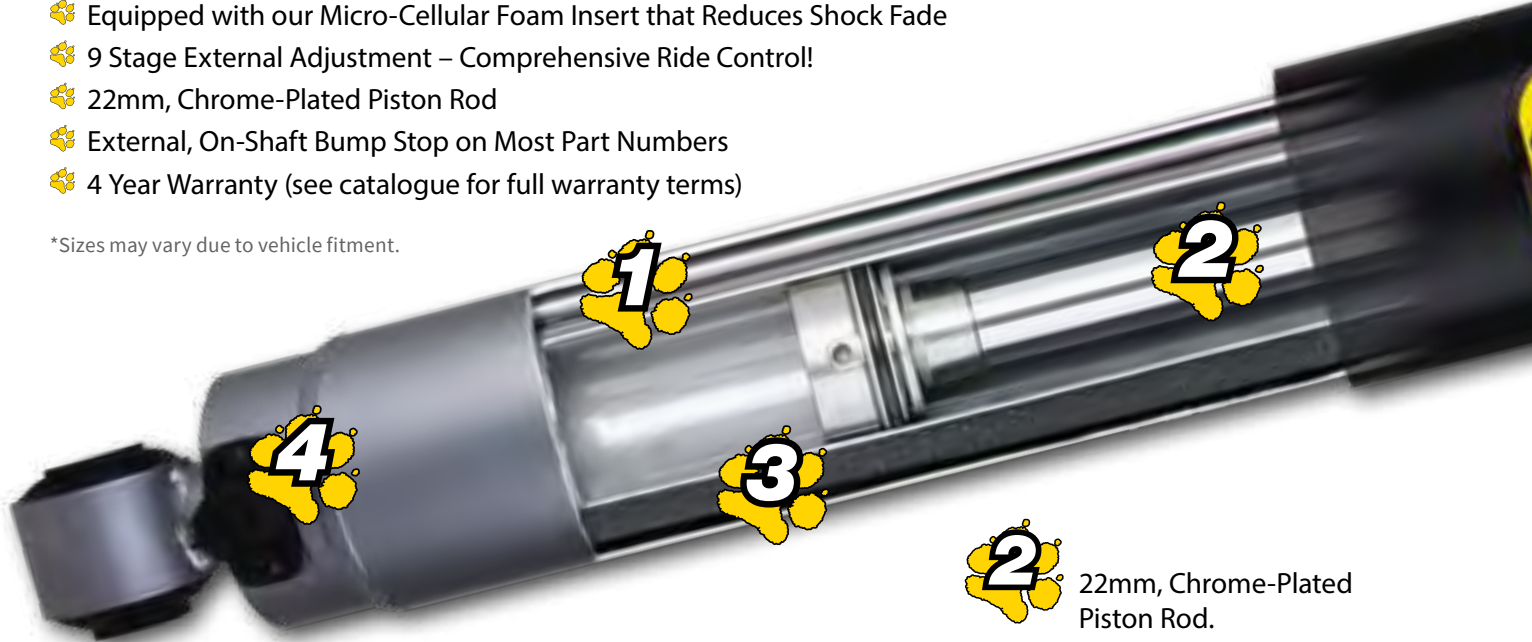

1 45mm Internal Bore with 70mm Outer Casing.

2 22mm, Chrome-Plated Piston Rod.

40mm ADJUSTABLE shock

- 🌟 40mm Internal Bore
- 🌟 60mm External Casing
- 🌟 18mm Piston Rod
- 🌟 Micro-Cellular Foam Insert
- 🌟 Reinforced Welded Eye Rings and Studs
- 🌟 4 Year Unlimited Km Warranty (see catalogue for full warranty terms)

*Sizes may vary due to vehicle fitment.



Complete solutions for most 4WDs
 visit www.toughdog.com.au to build your kit!



Fitting sheet (located page 243) must be completed when suspension fitted. Failure to comply may affect warranty.



9 Stage External Adjustment
 – Comprehensive Ride Control!



Equipped with our Micro-Cellular
 Foam Insert that Reduces
 Shock Fade.



**40MM & 45MM
 COMPLETE
 ASSEMBLY
 STRUTS
 AVAILABLE**



All prices exclude freight. Include only permanent accessories & weights when selecting. It is not included.

SPRINGS YOU CAN COUNT ON!

**MADE FROM
X5K STEEL**



COIL SPRINGS

Tough Dog coil springs are designed and manufactured in Australia to exacting standards to stand up to some of the harshest conditions found anywhere in the world.

Made from X5K spring steel, our coils are designed with less material while maintaining superior ride quality & load carrying characteristics. The spring retains its original memory even after heavy loading.

THE RESULT? A lighter, tougher coil that can handle just about anything you can throw at it.

- ✿ Shot Peened, Scragged and Load Tested for maximum durability
- ✿ Hot formed on precision mandrels to maintain spring memory
- ✿ Huge range of heights and load carrying options for most 4WD vehicles

LEAF SPRINGS

Designed in Australia, Tough Dog leaf springs offer a spring pack for just about any application you might require. Our springs are a proven performer in any situation.

Tough Dog leaf springs are a truly progressive rate leaf spring. Each leaf is set slightly higher than the leaf above so there is contact along the whole length of each leaf.

There are single stage and two stage springs available for different applications. Primary and secondary stage leaves ensure that the vehicle's ride remains uncompromised. As the spring is compressed under load, the heavier second stage leaves come into play to prevent excessive sag & remove high stresses from the primary stage.

0-300kg

Constant 300kg

Constant 500kg

Fitting sheet (located page 243) must be completed when suspension fitted. Failure to comply may affect warranty.

VARYING LOAD? NO WORRIES!

Tough Dog airbags are designed to exacting standards to stand up to some of the harshest conditions found anywhere in the world. If your load changes all the time, an 'Air Assist' suspension system could be for you.

'Air Assist' springs are specifically designed to level out and control the rear ride height of your vehicle.

- ✿ Laser Cut & Powder Coated Brackets
- ✿ Zinc Plated Roll Plates Top & Bottom
- ✿ No Drill Fitting (most applications)
- ✿ Eliminates Sway & Body Roll
- ✿ Guards Against Excessive Compression When Loaded
- ✿ 4 Year / Unlimited Kilometre Warranty



Heavy Duty Rubber



**5-100 psi (bellows)
5-60 psi (coil inserts)**



No Drill Fitting (most applications)



Suits Towing



Suits Heavy Load

BELLOWS AIRBAGS

Tough Dog 'Air Assist' rubber bellow airbags are designed for leaf spring vehicles where the load constantly varies.

Made from heavy duty rubber bellows with crimped end caps, these bellows will withstand the harshest environments found anywhere in the world.

COIL INSERT AIRBAGS

Tough Dog 'Air Assist' high density polyurethane airbags are designed for coil sprung vehicles to assist with varying loads and towing applications.

The heavy duty polyurethane bags can handle up to 60psi of pressure.



All prices exclude freight. Include only permanent accessories & weights when selecting springs. Towing weight is not included.

Quality steering components go a huge way to alleviating driver fatigue. Rough and unforgiving road surfaces can transfer through the wheels and up to the steering wheel.

If you're constantly fighting to keep the vehicle on track, eventually that effort will take its toll. Tough Dog steering dampers are on your side when it comes to taming steering shimmy and shake.



EXT

The Tough Dog EXT steering damper is our affordable, heavy duty replacement damper.

Featuring a 35mm internal bore and our Foam Cell insert, this damper will give you control and feeling back in your steering set up



RTC

The 'Return-to-Centre' damper is designed to re-centre your steering and help reduce shimmy and shake caused by rough road surfaces, reducing driver fatigue and increasing vehicle control.

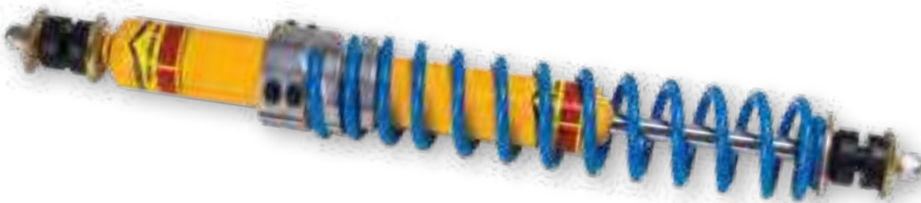

XHD RTC

These dampers are designed for vehicles with greater than 100mm of lift running large diameter or aggressive tyres. These dampers come with all necessary brackets.

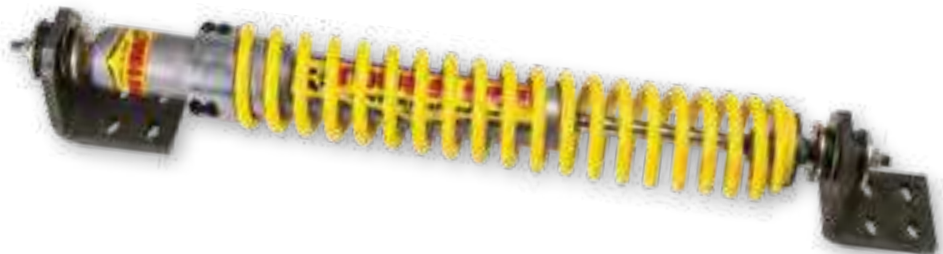

SV ADJUSTABLE

The 'SV' damper offers users the ability to adjust the damping force to suite driving style and vehicle requirements.

Available for most live axle vehicles, and up to 150mm lift in some applications.



Fitting sheet (located page 243) must be completed when suspension fitted. Failure to comply may affect warranty.

UPPER CONTROL ARMS

Tough Dog's Upper Control Arms are designed to return a vehicle's suspension and steering geometry to standard after it has been lifted, as well as allowing additional clearance between the coil and the upper arm during suspension travel.

Tough Dog UCAs can help get the maximum performance and lifespan from your suspension and steering components.



- ✿ Up to +3.5° Caster and up to -1.5° Camber (depending on final vehicle height)
- ✿ Fixed length and position design - guards against accidental misalignment during offroad use.
- ✿ Slimline tube design and ball joint housing to maximize clearance.
- ✿ Chromoly steel ball joint
- ✿ 1020 Grade Forged Bushing & Ball Joint Housings for high strength.
- ✿ Heavy Duty, High flex style bushing design - requires no lubrication and maximizes bushing life.
- ✿ Factory brake line mounting locations included.
- ✿ Designed to accept OEM components as replacements if needed.



IMPROVED CLEARANCE



HEAVY DUTY HIGH FLEX BUSHING



1020 GRADE FORGED HOUSINGS



CHROMOLY BALL JOINTS

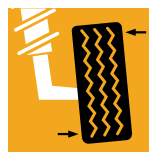

CORRECTS CASTER & CAMBER



CASTOR CORRECTION

Castor is the angle to which the steering pivot axis is tilted forward or rearward from vertical, as viewed from the side.

When a vehicle is lifted, the castor angle is adversely affected because of the change in the angles of the front radius arms.

Tough Dog provide a range of products to adjust camber from two degrees through to seven degrees to ensure a reliable straight steering feel is maintained at any lift height provided in the Tough Dog range.

OFFSET CAMBER PINS

Camber adjustment on live axle LandCruisers and Patrols can require an offset camber pin to be fitted. Available in 0.5, 0.75 and 1 degree of offset, these pins can help eliminate excessive and uneven tyre wear.



All prices exclude freight. Include only permanent accessories & weights when selecting springs. Towing weight is not included.

CARRY MORE - SAFELY & LEGALLY

The allowable payload on most modern 4WDs seems great on paper, but gets quickly eaten up when accessories, gear and passengers get loaded in.

Remaining under the vehicles Gross Vehicle Mass (GVM) can seem like an impossible feat.

Tough Dog Suspension is a recognised Second Stage Manufacturer (SSM) which allows us to develop and federally certify components to increase your vehicle's GVM. Maximise your allowable payload without risking your roadworthiness!

Each complete GVM kit has been extensively tested to ensure ADR compliance is maintained.



PRE-REGISTRATION VS POST-REGISTRATION

Certification of your GVM upgrade will occur on either a Federal or State level, depending on whether the vehicle has been registered or not.

Both Pre-Registration and Post-Registration kits must be supplied and installed through an authorised Tough Dog GVM installer.



When the GVM upgrade is completed prior to the first registration, the certification is done at a Federal level, and remains constant regardless of where in Australia the vehicle is registered.

When you collect and drive your new vehicle for the first time - it will be recognised as a Tough Dog upgraded vehicle.



If your vehicle is already registered, you're still able to take advantage of our GVM upgrade kits - Post Registration kits contain the same components as their pre-registration brothers, but require an additional signoff by a state engineer. Your local Tough Dog GVM approved dealer can help with certification.



Fitting sheet (located page 243) must be completed when suspension fitted. Failure to comply may affect warranty.

SAFETY & PERFORMANCE... BY DESIGN

Federal approval for GVM upgrades requires rigorous testing to ensure that the vehicle performs as well or better than when it left the original manufacturer.

You can be sure that your Tough Dog GVM will stop and handle well, even with the increased load on board.

Depending on the vehicle, testing is required for:

-  **Finite Element Analysis (FEA) testing:**
A check of the maximum load carrying capacity of the vehicle's axles.
-  **Brake Testing:** Laden and Unladen brake testing as well as testing under partial system failure to comply with ADR35/00.
-  **ESC Testing:** If required, this test ensures that the ESC system's response is the same or better than the original vehicle.



Every GVM kit comes complete with everything required, including necessary certification paperwork.

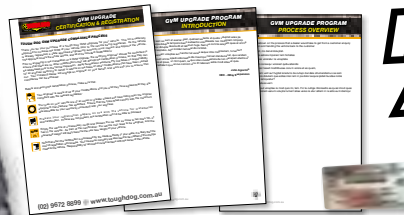



FEDERALLY APPROVED

4 YEAR WARRANTY*

*See catalogue for full warranty terms

UPGRADE TODAY

-  Specially Appointed Installers
-  Complete Peace of Mind
-  Find Your Nearest Installer at www.toughdog.com.au/dealers



Check out the latest range of certified kits at:

www.toughdog.com.au

All prices exclude freight. Include only permanent accessories & weights when selecting springs. Towing weight is not included.

4Way Suspension, the creators of Tough Dog suspension components, have identified a need in the armoured vehicle industry for a larger bore, extreme heavy duty,

comprehensive armoured vehicle replacement suspension solution. The first, and largest bore twin tube foam cell shock absorber is available, and it's available in your brand!

AVR SHOCK ABSORBERS

AVR 50mm Bore shock absorbers are the largest bore shocks available. The increased oil capacity results in superior handling and better vehicle control in all emergency situations.

- 1** 20mm Chrome Rod
- 2** Multi Lip Oil Seal
- 3** 70mm Outer Casing
- 4** Foam Cell Technology
- 5** High Temp Hydraulic Fluid
- 6** 50mm Internal Bore



IFS Vehicles transmit all of the weight of the vehicle through the lower strut eye bush. AVR utilise a multi layered design with a third metal ring laminated into the rubber for maximum strength and durability.

SWAY BARS

Controlling the body roll created by the substantial amount of weight added to the vehicle during the armoring process is imperative to maintaining good road holding characteristics. AVR have a range of Heavy Duty Sway Bars that will restore the handling qualities of the vehicle.

- 1** Solid steel construction
- 2** Direct Bolt-in Design
- 3** Complete fitting kit supplied
- 4** Australian Made Urethane Bushings



FITTING COMPONENTS

AVR complete armoured solutions means just that, we have the complete range of suspension components required for your project, including Australian made Urethane bushing kits, greasable pin and shackle replacements.



Fitting sheet (located page 243) must be completed when suspension fitted. Failure to comply may affect warranty.



COIL SPRINGS

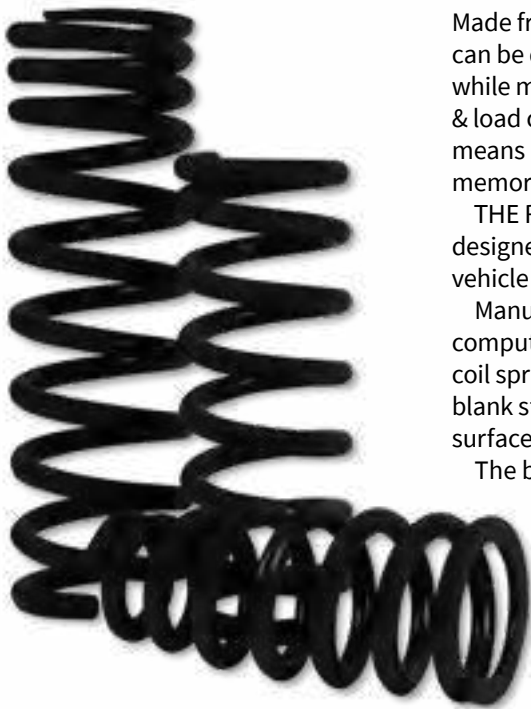

Made from X5K spring steel, our coils can be designed with less material while maintaining superior ride quality & load carrying characteristics. This means the spring retains its original memory even after heavy loading.

THE RESULT? A lighter, tougher coil designed specifically for armoured vehicle applications.

Manufactured using an exacting, computer controlled system, our AVR coil springs are CAD designed, and the blank steel is bar peeled to remove any surface defects.

The bar peeled steel is heated to

around 1000°C and then rolled into shape before being quenched in oil, which hardens the springs to 62HRC.

Once hardened, they are then tempered at 400°C, and if required, machine ground to suit the application.

After tempering, the coil is shot-peened, giving the coil a high intensity finish to ensure maximum fatigue life. Finally, each spring is phosphate coated for corrosion resistance, and powder coated to create the finished product.

- ✿ X5K spring steel
- ✿ Shot peened to relieve stress
- ✿ Scragged and load tested
- ✿ Hot formed to maintain spring memory
- ✿ Powdercoat finish



LEAF SPRINGS

Tough Dog leaf springs are a truly progressive rate leaf spring. Each leaf is set slightly higher than the leaf above so there is contact along the whole length of each leaf.

Flat bar steel in SUP9 and SUP9A grade is cut to length, then the centre hole, diamond cut ends, and other fixtures are cold pressed into the steel.

The military wraps and rolled eyes are formed, before the springs are heated to around 1000°C in a gas forge, and hot cambered to the required specifications. Quenched in oil to harden the springs, the leaves are then tempered by being re-heated in the forge. After tempering, the springs are shot-peened to a high

intensity finish and stress relieved to guard against sag in the spring.

Finally, each leaf is individually coated in primer and top coat to ensure that every part of the steel is coated. After assembly, the leaves are dipped in paint to ensure total coverage.



- ✿ SUP9 and SUP9A steel
- ✿ Shot peened to relieve stress
- ✿ Precision mandrel & die-formed
- ✿ Pre-stressed to maintain ride height
- ✿ Powdercoat finish

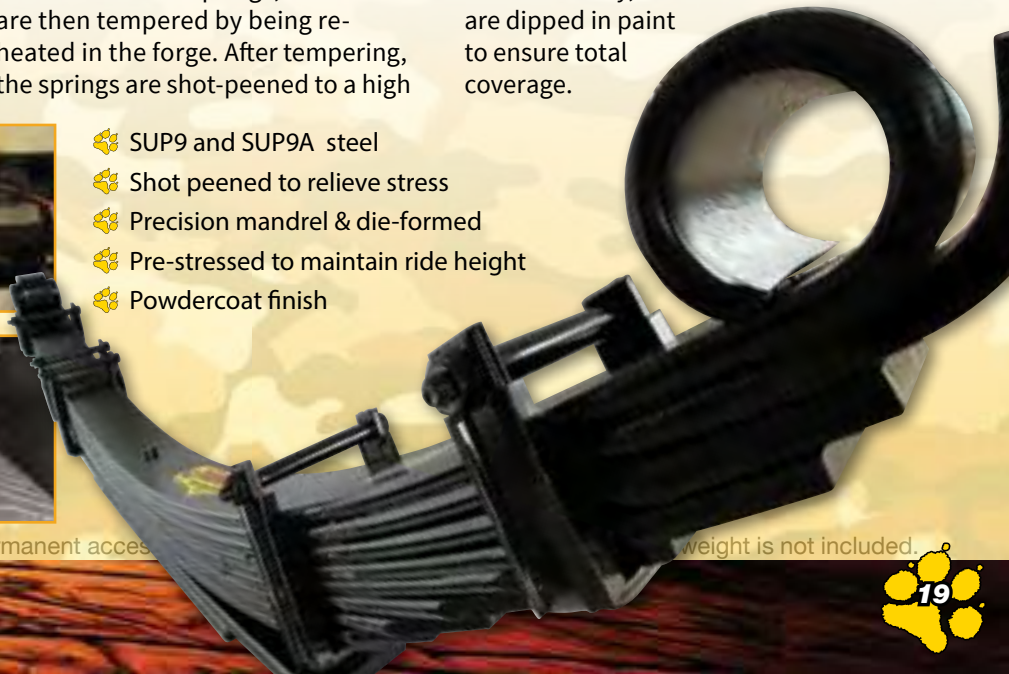

All prices exclude freight. Include only permanent accessories.

Weight is not included.



RECOVERY KIT WITH CHOICE OF 9M SNATCH STRAP: 8T OR 11T

When you get stopped in your tracks, the **Tough Dog Complete Recovery Kit** has everything you need to get back on track! Having a Tough Dog complete recovery kit on board gives you the confidence to know that no matter how stuck you get, you'll have the equipment to get back on track right there with you.

Every component is independently tested in Australia by NATA certified testing laboratories to ensure it won't let you down! With all the essentials for both snatch and winch recovery situations packed into the heavy duty bag, you'll always be prepared.

All components also available separately

- ✿ 1 x 9 metre - 8,000kg **OR** 11,000kg Snatch Strap
- ✿ 1 x 3 metre 10,000kg Tree Trunk Protector
- ✿ 1 x 20 metre 10,000kg winch extension strap
- ✿ 1 x 10,000kg Pulley Block
- ✿ 2 x 4.75T W.L.L Bow Shackles
- ✿ 1 x Leather/synthetic work gloves
- ✿ 1 x Recovery Damper Blanket
- ✿ Heavy duty carry bag
- ✿ 3 year warranty (material & manufacture)

Fitting sheet (located page 243) must be completed when suspension fitted. Failure to comply may affect warranty.

RECOVERY ACCESSORIES

PRODUCT	PART NO.
8T complete recovery kit	TDRK-08T
11T complete recovery kit	TDRK-11T
8T 9M snatch strap	TDRG-001
11T 9M snatch strap	TDRG-002
10T 3m Tree Trunk Protector / Equalizer Strap	TDRG-003
10T 20M Winch Extension Strap	TDRG-004
10T Pulley Block	TDRG-005
4.75T Bow Shackle	TDRG-006



SNATCH STRAPS

When you get stopped in your tracks, the Tough Dog snatch strap is the quick and easy answer for a vehicle assisted recovery. Made from 100% Nylon, snatch straps harness kinetic energy by stretching under load, getting you out of trouble quickly and easily.

WINCH EXTENSION STRAP



When you're out making tracks and you need a long winch recovery, the Tough Dog winch extension strap is the perfect partner to your winch. This strap has minimal stretch & maximum strength for winch recoveries.

TREE TRUNK PROTECTOR



The Tough Dog Tree Trunk Protector is designed for use as both an equaliser strap for snatching, or as a tree trunk protector when winching. Essential for every type of recovery!

4.75T BOW SHACKLE

An essential addition to every recovery kit, these bow shackles can be used in conjunction with winches or snatch straps to assist in recovery. Shackles should only be used on vehicles fitted with recovery rated points featuring closed eyelets.



WINCH PULLEY BLOCK

Complex winch recoveries often need a change of angle, or a multiplication of pulling force through a double line winch pull. The Tough Dog pulley block is a key part of any recovery kit, allowing you to alter the line direction of your winch without damaging your winch cable or rope.



HEAVY DUTY 1200 DENIER RECOVERY BAG



HEAVY DUTY RECOVERY GLOVES

All prices exclude freight. Include only permanent accessories & weights when selecting springs. Towing weight is not included.



TORSION BARS

Tough Dog Performance 4WD Torsion Bars offer a spring rate that is approximately 30% higher than OEM torsion bars.

Optimise your 4WD's ride & handling characteristics with quality torsion bars from ToughDog!

PANHARD RODS

Adjustable panhard rods allow the axle to be re-centred under the vehicle after the height has been modified.

Tough Dog panhard rods are bent from a single solid bar for strength, and are adjustable to cover a broad range of vehicle heights.



PINS & SHACKLES

Greasable pins and shackles help protect the bushes from premature wear because of the ingress of dirt and grit. Greasable components are particularly important to vehicles exposed to outback dust or high salt level environments like boat ramps and beach driving.

U-BOLT KITS

When U-bolts are tightened to secure the leaf pack in the vehicle from factory, the metal is stretched as a normal part of this process. It is important that U-bolts be replaced when a suspension system is changed, as a stretched U-bolt has lost its integral strength.

Tough Dog U-bolts are manufactured using high tensile steel & are designed with the correct length of thread for larger, heavy duty leaf spring packs.



URETHANE BUSHES & SPACERS

Tough Dog urethane is stronger than rubber components and has greater longevity and resistance to deterioration from chemical exposure. Urethane bushes respond well to greasing during operation, and are created to retain flexibility for ride comfort.

Replacement urethane bushes are available for all Tough Dog leaf springs as well as for a range of other suspension bushing locations in vehicles.

Fitting sheet (located page 243) must be completed when suspension fitted. Failure to comply may affect warranty.



BRAKE HOSES

Extended brake lines become a requirement for larger lift vehicles to prevent damage from stretching the existing lines. Tough Dog offer a brake line solution in both a tradition rubber style as well as a steel braided line for improved brake pedal response and feel.

STRUT TOPS

Replacement strut tops are available separately for most modern vehicles. These units are suitable for use with Tough Dog product and with original manufacturers struts as well.



Sway Bar Spacers

TDSK-021



TDSP-004-2



TDSP-010



TDSP-008

FITTING KITS

Tough Dog pays close attention to the fit and finish of every complete solution. We have a range of fitting brackets and vehicle specific components.

Check out our complete catalogue listing for components to suit your vehicle.

All prices exclude freight. Include only permanent accessories & weights when selecting springs. Towing weight is not included.

RECOVERY KITS & COMPONENTS

PART NO.	Qty	DESCRIPTION	NOTES
RECOVERY KITS			
TDRK-08T	1	8T Complete Recovery Kit	Includes 8 Tonne Snatch Strap
TDRK-11T	1	11T Complete Recovery Kit	Inclues 11 Tonne Snatch Strap
INDIVIDUAL RECOVERY COMPONENTS			
TDRG-001	1	8 Tonne Snatch Strap	9 Metres 20% Stretch
TDRG-002	1	11 Tonne Snatch Strap	9 Metres 20% Stretch
TDRG-003	1	10 Tonne Tree Trunk Protector	3 Metres Double Stitched
TDRG-004	1	10 Tonne Winch Extension Strap	20 Metres
TDRG-005	1	10 Tonne Pulley Block	Greasable Centre Pin
TDRG-006	1	4.75 Tonne W.L.L Bow Shackle	Hot Dipped Galvanised Coating

PRODUCT DETAILS

PART NO.	LENGTH	M.B.S	COLOUR	NOTES
RECOVERY COMPONENT SPECIFICATION				
TDRG-001	9 M	8,000KG	Yellow	100% Nylon, 20% Stretch
TDRG-002	9 M	11,000KG	Orange	100% Nylon, 20% Stretch
TDRG-003	9 M	10,000KG	Purple	
TDRG-004	20 M	10,000KG	Green	
TDRG-005		10,000KG	Yellow	Greasable Centre Pin
TDRG-006		4.75 W.L.L	Yellow	Hot Dipped Galvanised Coating
Damper Blanket	Not For Individual Sale		Black	PVC Blanket With Weight Pockets
Gloves	Not For Individual Sale		Black	Synthetic Outer Leather Palm With Grip & FingerPads
Storage Bag	Not For Individual Sale		Red/Black	1200 Denier Material, Self Supporting Main Opening

Fitting sheet (located page 243) must be completed when suspension fitted. Failure to comply may affect warranty.

COMPLETE KIT INCLUDES



1	8T Snatch Strap
OR	
1	11T Snatch Strap
1	10T Winch Extension Strap
1	10T Tree Trunk Protector
1	10T Pulley Block
2	4.75T W.L.L Bow Shackles
1	Pair Gloves
1	Recovery Damper Blanket
1	Heavy Duty Recovery Bag



8T & 11T Snatch Strap



10T Winch Extension Strap

10T Tree Trunk Protector



Heavy Duty 1200 Denier Recovery Bag



4.75T Bow Shackles



10T Pulley Block



Heavy Duty Gloves

GVM UPGRADES CAN ONLY BE ORDERED THROUGH A TOUGH DOG APPROVED GVM DEALER

WHAT IS A GVM UPGRADE?

The GVM, or Gross Vehicle Mass of any vehicle is the weight in KG that the manufacturer has specified as being the maximum that the vehicle can weigh when fully loaded. Tough Dog GVM upgrades allow a vehicle to be certified to carry a greater amount than the original manufacturer, without breaching applicable ADRs or laws.

GVM upgrades for new vehicles are undertaken at the Second Stage of Manufacture (SSM) to the vehicle (after the First Stage of Manufacture) and are only certifiable by the Federal Government via the Department of Infrastructure, Transport, Regional Development and Communications.



FEDERAL OR STATE APPROVAL - PRE OR POST REGISTRATION

You can upgrade the GVM of a vehicle using either Federal approval or state based approval, depending on whether the vehicle has been registered or not. If the vehicle has never been registered, Federal approval can be applied, the GVM kit comes complete with an additional compliance plate which will be fixed to the vehicle.

If the vehicle is already registered, the evidence used in Federal compliance is used in conjunction with a vehicle inspection by an authorised state engineer to certify the vehicle. Federal compliance cannot be achieved on a vehicle that has already been registered.

SAFETY FIRST - NEVER OVERLOAD YOUR VEHICLE YOU MUST NOT EXCEED THE MAX. CERTIFIED GVM

ALWAYS BE AWARE OF:

Fitment of a GVM Kit **MUST** be carried out by an Authorised Tough Dog fitting facility. DIY fitment or fitment by a non-authorised fitting station will result in the kit not achieving certification.

FRONT & REAR AXLE LOADS:

The maximum load applied to the individual axles must not be exceeded. Tough Dog GVM kits specify the maximum axle loading in both the front and rear axles, the owner or operator is responsible to ensure the vehicle so as not to exceed the maximum rating per axle.

TYRE LOAD RATINGS:

Tyres fitted to the vehicles **MUST** meet or exceed the original tyre load ratings to remain compliant. Compliance is the responsibility of the owner or operator.

MINIMUM PAYLOAD

Some Tough Dog GVM kits specify a minimum payload that the vehicle must achieve. This is a requirement of the kit. Compliance testing is carried out to a minimum (unladen) and maximum (laden) weights. The weight of the vehicle must fall within that window to remain compliant.



GVM UPGRADES

FORD - RANGER PXIII

08/2018 ON



GVM UPGRADES CAN ONLY BE ORDERED THROUGH A TOUGH DOG APPROVED GVM DEALER

VARIANT AND SPECIFICATION INFORMATION

Original GVM	3200 KG	Suitable for the following vehicle variants: Single, Space & Dual Cab, 4x2 Hi-Rider & 4WD ONLY Note - Additional Load (permanent fixtures or cargo) must not cause the front & rear individual axle loads to be exceeded. Weight is not transferrable from one axle to the other
Revised Tough Dog GVM	3510 KG	
Revised max front axle load	1480 KG	
Revised max rear axle load	2030 KG	
IPA Approval Number	50816	

KIT OPTIONS

PART NO.	MIN. KG	REGISTRATION	NOTES	
Suitable for Single Cab & Space Cab vehicles only				
GVM KITS	TDGVM-017	600 KG	Pre Registration (Federal Approval) Bar	Front Foam Cell Assembled Struts x 2 Rear Foam Cell Shocks x 2 Rear Leaf Springs x 2
	TDGVM-021	600 KG	Pre Registration (Federal Approval) Bar & Winch	Rear U-Bolts x 2 Rear Leaf Spring Bush Kit x 1
	TDGVM-018	600 KG	Post Registration (State Approval) Bar	Rear Greasable Shackle Set x 1 Rear Greasable Pin Set x 1
	TDGVM-022	600 KG	Post Registration (State Approval) Bar & Winch	Transmission Spacer Kit x 1 Fitting Instruction Kit x 1
	Suitable for Double Cab vehicles only			
	TDGVM-019	400 KG	Pre Registration (Federal Approval) Bar	Front Foam Cell Assembled Struts x 2 Rear Foam Cell Shocks x 2 Rear Leaf Springs x 2
	TDGVM-023	400 KG	Pre Registration (Federal Approval) Bar & Winch	Rear U-Bolts x 2 Rear Leaf Spring Bush Kit x 1
	TDGVM-020	400 KG	Post Registration (State Approval) Bar	Rear Greasable Shackle Set x 1 Rear Greasable Pin Set x 1
TDGVM-024	400 KG	Post Registration (State Approval) Bar & Winch	Transmission Spacer Kit x 1 Fitting Instruction Kit x 1	

All prices exclude freight. Include only permanent accessories & weights when selecting springs. Towing weight is not included.





GVM UPGRADES CAN ONLY BE ORDERED THROUGH A TOUGH DOG APPROVED GVM DEALER

VARIANT AND SPECIFICATION INFORMATION

Original GVM	3000 KG (4X2) - 3100 KG (4X4)	Suitable for the following vehicle variants: SINGLE, SPACE & CREW CAB 4X4 / 4X2 HI-RIDER Note - Additional Load (permanent fixtures or cargo) must not cause the front & rear individual axle loads to be exceeded. Weight is not transferrable from one axle to the other
Revised Tough Dog GVM	3695 KG	
Revised max front axle load	1595 KG	
Revised max rear axle load	2100 KG	
IPA Approval Number	51585	

KIT OPTIONS

PART NO.	MIN. KG	REGISTRATION	NOTES	
Suitable for Single Cab & Space Cab vehicles only				
GVM KITS	TDGVM-027	400 KG	Pre Registration (Federal Approval)	Front Foam Cell Assembled Struts x 2 Rear Foam Cell Shocks x 2 Rear Leaf Springs x 2 Rear U-Bolts x 2
	TDGVM-028	400 KG	Post Registration (State Approval)	Rear Leaf Spring Bush Kit x 1 Rear Greasable Shackle Set x 1 Rear Greasable Pin Set x 1 Fitting Instruction Kit x 1
Suitable for Double Cab vehicles only				
GVM KITS	TDGVM-029	300 KG	Pre Registration (Federal Approval)	Front Foam Cell Assembled Struts x 2 Rear Foam Cell Shocks x 2 Rear Leaf Springs x 2 Rear U-Bolts x 2
	TDGVM-030	300 KG	Post Registration (State Approval)	Rear Leaf Spring Bush Kit x 1 Rear Greasable Shackle Set x 1 Rear Greasable Pin Set x 1 Fitting Instruction Kit x 1

Fitting sheet (located page 243) must be completed when suspension fitted. Failure to comply may affect warranty.



GVM UPGRADES

MAZDA - BT-50
08/2020 ON



GVM UPGRADES CAN ONLY BE ORDERED THROUGH A TOUGH DOG APPROVED GVM DEALER

VARIANT AND SPECIFICATION INFORMATION

Original GVM	3000 KG (4X2) - 3100 KG (4X4)	Suitable for the following vehicle variants:
Revised Tough Dog GVM	3695 KG	SINGLE, FREESTYLE & DUAL CAB 4X4 / 4X2 HI-RIDER
Revised max front axle load	1595 KG	Note - Additional Load (permanent fixtures or cargo) must not cause the front & rear individual axle loads to be exceeded. Weight is not transferrable from one axle to the other
Revised max rear axle load	2100 KG	
IPA Approval Number	51584	

KIT OPTIONS

PART NO.	MIN. KG	REGISTRATION	NOTES	
Suitable for Single Cab & Super Cab vehicles only				
GVM KITS	TDGVM-031	400 KG	Pre Registration (Federal Approval)	Front Foam Cell Assembled Struts x 2 Rear Foam Cell Shocks x 2 Rear Leaf Springs x 2 Rear U-Bolts x 2
	TDGVM-032	400 KG	Post Registration (State Approval)	Rear Leaf Spring Bush Kit x 1 Rear Greasable Shackle Set x 1 Rear Greasable Pin Set x 1 Fitting Instruction Kit x 1
Suitable for Double Cab vehicles only				
GVM KITS	TDGVM-033	300 KG	Pre Registration (Federal Approval)	Front Foam Cell Assembled Struts x 2 Rear Foam Cell Shocks x 2 Rear Leaf Springs x 2 Rear U-Bolts x 2
	TDGVM-034	300 KG	Post Registration (State Approval)	Rear Leaf Spring Bush Kit x 1 Rear Greasable Shackle Set x 1 Rear Greasable Pin Set x 1 Fitting Instruction Kit x 1

All prices exclude freight. Include only permanent accessories & weights when selecting springs. Towing weight is not included.





GVM UPGRADES CAN ONLY BE ORDERED THROUGH A TOUGH DOG APPROVED GVM DEALER

VARIANT AND SPECIFICATION INFORMATION

Original GVM	2900 KG - 3100 KG	Suitable for the following vehicle variants:
Revised Tough Dog GVM	3510 KG	SINGLE, XTRA & DUAL 4X2 HI RIDER & 4WD
Revised max front axle load	1510 KG	Note - Additional Load (permanent fixtures or cargo) must not cause the front & rear individual axle loads to be exceeded. Weight is not transferrable from one axle to the other
Revised max rear axle load	2000 KG	
IPA Approval Number	50918	

KIT OPTIONS

GVM KITS	PART NO.	MIN. KG	REGISTRATION	NOTES
	TDGVM-013	300 KG	Pre Registration (Federal Approval)	Front Foam Cell Assembled Struts x 2 Rear Foam Cell Shocks x 2 Rear Leaf Springs x 2 Rear U-Bolts x 2 Rear Leaf Spring Bush Kit x 1 Rear Greasable Shackle Set x 1 Rear Greasable Pin Set x 1 Centre Bearing Spacer Kit x 1 Fitting Instruction Kit x 1
	TDGVM-014	300 KG	Post Registration (State Approval)	
	TDGVM-015	600 KG	Pre Registration (Federal Approval)	
	TDGVM-016	600 KG	Post Registration (State Approval)	

Fitting sheet (located page 243) must be completed when suspension fitted. Failure to comply may affect warranty.



GVM UPGRADES CAN ONLY BE ORDERED THROUGH A TOUGH DOG APPROVED GVM DEALER

VARIANT AND SPECIFICATION INFORMATION

Original GVM	3300 KG - 3330 KG	Suitable for the following vehicle variants:
Revised Tough Dog GVM	3950 KG	LANDCRUISER VDJ78 TROOP CARRIER VARIANTS
Revised max front axle load	1540 KG	Note - Additional Load (permanent fixtures or cargo) must not cause the front & rear individual axle loads to be exceeded. Weight is not transferrable from one axle to the other
Revised max rear axle load	2410 KG	
IPA Approval Number	50400	

KIT OPTIONS

PART NO.	MIN. KG	REGISTRATION	NOTES	
GVM KITS	TDGVM-009	0 KG	Pre Registration (Federal Approval)	Front Foam Cell Shocks x 2 Rear Foam Cell Shocks x 2
GVM KITS	TDGVM-010	0 KG	Post Registration (State Approval)	Front Coil Springs x 2 Rear Leaf Springs x 2 Front Castor Bush Kit x 1 Rear U-Bolts x 2
GVM KITS	TDGVM-011	700 KG	Pre Registration (Federal Approval)	Rear Leaf Spring Bush Kit x 1 Rear Greasable Shackle Set x 1 Rear Greasable Pin Set x 1
GVM KITS	TDGVM-012	700 KG	Post Registration (State Approval)	Cat 6 Side Direction Indicator Set x 1 Fitting Instruction Kit x 1



GVM UPGRADES CAN ONLY BE ORDERED THROUGH A TOUGH DOG APPROVED GVM DEALER

VARIANT AND SPECIFICATION INFORMATION

Original GVM	3300-3400 KG (S/Cab) 3300 KG (D/Cab)	Suitable for the following vehicle variants:
Revised Tough Dog GVM	3950 KG	
Revised max front axle load	1540 KG	Note - Additional Load (permanent fixtures or cargo) must not cause the front & rear individual axle loads to be exceeded. Weight is not transferrable from one axle to the other
Revised max rear axle load	2410 KG	
IPA Approval Number	50400	

KIT OPTIONS

	PART NO.	MIN. KG	REGISTRATION	NOTES
GVM KITS	TDGVM-005	0 KG	Pre Registration (Federal Approval)	Front Foam Cell Shocks x 2 Rear Foam Cell Shocks x 2
	TDGVM-006	0 KG	Post Registration (State Approval)	Front Coil Springs x 2 Rear Leaf Springs x 2 Front Castor Bush Kit x 1 Rear U-Bolts x 2
	TDGVM-007	700 KG	Pre Registration (Federal Approval)	Rear Leaf Spring Bush Kit x 1 Rear Greasable Shackle Set x 1 Rear Greasable Pin Set x 1
	TDGVM-008	700 KG	Post Registration (State Approval)	Cat 6 Side Direction Indicator Set x 1 Fitting Instruction Kit x 1

Fitting sheet (located page 243) must be completed when suspension fitted. Failure to comply may affect warranty.



GVM UPGRADES CAN ONLY BE ORDERED THROUGH A TOUGH DOG APPROVED GVM DEALER

VARIANT AND SPECIFICATION INFORMATION		
Original GVM	3300 KG (2011) 3350 KG (2011 On)	Suitable for the following vehicle variants: GX ONLY
Revised Tough Dog GVM	3830 KG (2011-08/2014) 3850 KG (08/2014 On)	
Max front axle load	1630KG (2011-08/2014) 1700 KG (08/2014 On)	
Revised max rear axle load	2200 KG	Note - Additional Load (permanent fixtures or cargo) must not cause the front & rear individual axle loads to be exceeded. Weight is not transferrable from one axle to the other
IPA Approval Number	50376	

KIT OPTIONS

	PART NO.	MIN. KG	REGISTRATION	NOTES
GVM KITS	TDGVM-003	0 KG	Pre Registration (Federal Approval)	Front Foam Cell Assembled Struts x 2 Rear Foam Cell Shocks x 2 Rear Coil Springs x 2 Cat 6 Side Direction Indicator Set x 1 Fitting Instruction Kit x 1
	TDGVM-026	0 KG	Post Registration (State Approval) 2011-08/2014 ONLY	
	TDGVM-004	0 KG	Post Registration (State Approval) 08/2014 On	



GVM UPGRADES CAN ONLY BE ORDERED THROUGH A TOUGH DOG APPROVED GVM DEALER

VARIANT AND SPECIFICATION INFORMATION		
Original GVM	3300 KG (2007-2011) 3350 KG (2012 On)	Suitable for the following vehicle variants:
Revised Tough Dog GVM	3830 KG (2007-08/2014) 3850 KG (08/2014 On)	GXL, VX, SAHARA
Max front axle load	1630KG (2007-08/2014) 1700 KG (08/2014 On)	Note - Additional Load (permanent fixtures or cargo) must not cause the front & rear individual axle loads to be exceeded. Weight is not transferrable from one axle to the other
Revised max rear axle load	2200 KG	
IPA Approval Number	50375	

KIT OPTIONS

	PART NO.	MIN. KG	REGISTRATION	NOTES
GVM KITS	TDGVM-001	0 KG	Pre Registration (Federal Approval)	Front Foam Cell Assembled Struts x 2 Rear Foam Cell Shocks x 2 Rear Coil Springs x 2 Fitting Instruction Kit x 1
	TDGVM-025	0 KG	Post Registration (State Approval) 2007-08/2014 ONLY	
	TDGVM-002	0 KG	Post Registration (State Approval) 08/2014 On	



THIS PAGE IS INTENTIONALLY BLANK



FRONT SUSPENSION

ESTIMATED LIFT: 50mm

PART NO.	Qty	DESCRIPTION	NOTES
SHOCK ABSORBERS			
BD1102T	2	Nitrogen Gas Shock	Suits OE Height Only
BM401102	2	40mm Adjustable Shock	
BD1104T	2	Nitrogen Gas Shock	Suits 50mm Lift
BM401104	2	40mm Adjustable Shock	
STEERING DAMPER			
SD5700	1	Steering Damper	
COMPONENTS			
TDUK-001	1	Urethane Shackle Bushing Kit	
TDUB-001	2	U-Bolt Kit	

REAR SUSPENSION

PART NO.	Qty	DESCRIPTION	NOTES
SHOCK ABSORBERS			
BD1364T	2	Nitrogen Gas Shock	Suits OE Height Only
BM401364	2	40mm Adjustable Shock	
BD1366T	2	Nitrogen Gas Shock	Suits 50mm Lift
BM401366	2	40mm Adjustable Shock	
COMPONENTS			
TDUK-001	1	Urethane Shackle Bushing Kit	
TDUB-001	2	U-Bolt Kit	

REPLACEMENT BUSHINGS

PART NO.	Qty	DESCRIPTION	NOTES
QUANTITY PER SHOCK			
TW959	2	Front Top Pin Mount	Pin Style Bushing
404702	1	Bottom Front Eying	Eying Bushing
404702	2	Top & Bottom Rear Eying	Eying Bushing

Fitting sheet (located page 243) must be completed when suspension fitted. Failure to comply may affect warranty.



DAEWOO

MUSSO

07/1998-2002



FRONT SUSPENSION

ESTIMATED LIFT: 35mm

PART NO.	Qty	DESCRIPTION	NOTES
SHOCK ABSORBERS			
BD2057T	2	Nitrogen Gas Shock	Suits up to 35mm Lift
TORSION BARS			
4WTB-1800	1	Replacement Torsion Bars (Pair)	26mm/1040mm
Adjust Torsion bars after fitting shocks - Ensure a minimum of 60mm droop is maintained			

REAR SUSPENSION

PART NO.	Qty	DESCRIPTION	NOTES
SHOCK ABSORBERS			
BD1104T	2	Nitrogen Gas Shock	Suits OE Height Only
BM401104	2	40mm Adjustable Shock	
BD1105T	2	Nitrogen Gas Shock	Suits 35mm Lift
BM401105	2	40mm Adjustable Shock	
COIL SPRINGS			
TDC100	1	0-300KG Load	35mm Lift (Pair)
TDC100H	1	CONSTANT 300Kg Load	35mm Lift (Pair)

REPLACEMENT BUSHINGS

PART NO.	Qty	DESCRIPTION	NOTES
QUANTITY PER SHOCK			
TW959	2	Suit top pin mount (F & R)	Pin style bushing
412772	1	Suits bottom eye mount (F & R)	Eyering bushing

All prices exclude freight. Include only permanent accessories & weights when selecting springs. Towing weight is not included.



FRONT SUSPENSION

ESTIMATED LIFT: 50mm

PART NO.	Qty	DESCRIPTION	NOTES
SHOCK ABSORBERS			
BD1364T	2	Nitrogen Gas Shock	Suits OE Height Only
BM401364	2	40mm Adjustable Shock	
BD1366T	2	Nitrogen Gas Shock	Suits 50mm Lift
BM401366	2	40mm Adjustable Shock	
COMPONENTS			
TDUK-019	1	Urethane Shackle Bushing Kit	All Excluding F50
TDUK-020	1	Urethane Shackle Bushing Kit	Suits F50 Only
TDUB-027	2	U-Bolt Kit	

REAR SUSPENSION

PART NO.	Qty	DESCRIPTION	NOTES
SHOCK ABSORBERS			
BD1366T	2	Nitrogen Gas Shock	Suits OE Height Only
BM401366	2	40mm 9 Stage Adjustable Shock	
BD1382T	2	Nitrogen Gas Shock	Suits 50mm Lift
BM401382	2	40mm 9 Stage Adjustable Shock	
COMPONENTS			
TDUK-019	1	Urethane Shackle Bushing Kit	All Excluding F50
TDUK-020	1	Urethane Shackle Bushing Kit	Suits F50 Only
TDUB-027	2	U-Bolt Kit	

REPLACEMENT BUSHINGS

PART NO.	Qty	DESCRIPTION	NOTES
QUANTITY PER SHOCK			
404702	2	Suits Top & Bottom, Front & Rear	Eyering bushing

Fitting sheet (located page 243) must be completed when suspension fitted. Failure to comply may affect warranty.



FRONT SUSPENSION

ESTIMATED LIFT: 50mm

PART NO.	Qty	DESCRIPTION	NOTES
SHOCK ABSORBERS			
BD1366T	2	Nitrogen Gas Shock	Suits OE Height Only
BM401366	2	40mm Adjustable Shock	
BD1382T	2	Nitrogen Gas Shock	Suits 50mm Lift
BM401382	2	40mm Adjustable Shock	
COMPONENTS			
TDUK-002	1	Urethane Shackle Bushing Kit	
TDUB-027	2	U-Bolt Kit	

REAR SUSPENSION

PART NO.	Qty	DESCRIPTION	NOTES
SHOCK ABSORBERS			
BD1400T	2	Nitrogen Gas Shock	Suits OE Height Only
BM401400	2	40mm Adjustable Shock	
BD1441T	2	Nitrogen Gas Shock	Suits 50mm Lift
BM401441	2	40mm Adjustable Shock	
COMPONENTS			
TDUK-023	1	Urethane Shackle Bushing Kit	
TDUB-027	2	U-Bolt Kit	

REPLACEMENT BUSHINGS

PART NO.	Qty	DESCRIPTION	NOTES
QUANTITY PER SHOCK			
404702	2	Suits Top & Bottom, Front mounts	Eyering bushing
404702	1	Suits Top rear mount	Eyering bushing
TW959	2	Suits bottom rear mount	Bushing



FRONT SUSPENSION

ESTIMATED LIFT: 40mm

PART NO.	Qty	DESCRIPTION	NOTES
SHOCK ABSORBERS			
BD2057T	2	Nitrogen Gas Shock	All Applications
TORSION BARS			
4WTB-0197	1	Replacement Torsion Bars (Pair)	26mm/1093mm
Adjust Torsion bars after fitting shocks - Ensure a minimum of 60mm droop is maintained			

REAR SUSPENSION

PART NO.	Qty	DESCRIPTION	NOTES
SHOCK ABSORBERS			
BD1102T	2	Nitrogen Gas Shock	Suit OE Height
BM401102	2	40mm Adjustable Shock	
BD1104T	2	Nitrogen Gas Shock	Suit 40mm Lift
BM401104	2	40mm Adjustable Shock	
LEAF SPRINGS			
T67	2	0-300KG Load	40mm Lift
COMPONENTS			
TDUK-003	1	Urethane Shackle Bushing Kit	
TDUB-027	2	U-Bolt Kit	

REPLACEMENT BUSHINGS

PART NO.	Qty	DESCRIPTION	NOTES
QUANTITY PER SHOCK			
TW959	2	Suits Top Front Pin Bushing	Pin Style Busing
412773	1	Suits Bottom Front Eye Busing	Eyering Bushing
TW959	2	Suits Top Rear Pin Bushing	Pin Style Busing
404702	1	Suits Bottom Rear Eye Bushing	Eyering Bushing

Fitting sheet (located page 243) must be completed when suspension fitted. Failure to comply may affect warranty.



DAIHATSU

FEROZA II - F310

04/1992-1998



FRONT SUSPENSION

ESTIMATED LIFT: 40mm

PART NO.	Qty	DESCRIPTION	NOTES
SHOCK ABSORBERS			
BD2057T	2	Nitrogen Gas Shock	All Applications
TORSION BARS			
4WTB-0197	1	Replacement Torsion Bars (Pair)	26mm/1093mm
Adjust Torsion bars after fitting shocks - Ensure a minimum of 60mm droop is maintained			

REAR SUSPENSION

PART NO.	Qty	DESCRIPTION	NOTES
SHOCK ABSORBERS			
BD1005T	2	Nitrogen Gas Shock	Suit OE Height
BM401005	2	40mm Adjustable Shock	
BD1007T	2	Nitrogen Gas Shock	Suit 40mm Lift
BM401007	2	40mm Adjustable Shock	
LEAF SPRINGS			
T76	2	0-300 KG Load	40mm Lift
COMPONENTS			
TDUK-022	1	Urethane Shackle Bushing Kit	
TDUB-027	2	U-Bolt Kit	

REPLACEMENT BUSHINGS

PART NO.	Qty	DESCRIPTION	NOTES
QUANTITY PER SHOCK			
TW959	2	Suits Top Front Pin Bushing	Pin Style Busing
412772	1	Suits Bottom Front Eye Busing	Eyering Bushing
TW959	4	Suits Top & Bottom Rear Pin Bushing	Pin Style Busing

All prices exclude freight. Include only permanent accessories & weights when selecting springs. Towing weight is not included.





FRONT SUSPENSION

ESTIMATED LIFT: 40mm

PART NO.	Qty	DESCRIPTION	NOTES
SHOCK ABSORBERS			
BD1102TB	2	Nitrogen Gas Shock	Suit OE Height
BM401102	2	40mm Adjustable Shock	
BD1104TB	2	Nitrogen Gas Shock	Suit 40mm Lift
BM401104	2	40mm Adjustable Shock	
LEAF SPRINGS			
1 Left Hand Side and 1 Right Hand Side leaf spring pack should be ordered			
LWB			
T65-LH	1	Petrol/Diesel/Bar	Suit LWB Except F77, F87 Left Hand Side
T65-RH	1	Petrol/Diesel/Bar	Suit LWB Except F77, F87 Right Hand Side
SWB			
T65C-LH	1	Petrol/Diesel/Bar	Suit SWB Except F77, F87 Left Hand Side
T65C-RH	1	Petrol/Diesel/Bar	Suit SWB Except F77, F87 Right Hand Side
ADDITIONAL COMPONENTS			
TDUK-002	1	Urethane Shackle Bushing Kit	Suits D/S (1 Kit Required Except F77, F87) 2 Kits required F77, F87 Suits P/S (1 Kit Required Except F77, F87) Not required F77, F87
TDUB-002	1	U-Bolt Kit	
TDUB-027	1	U-Bolt Kit	

REAR SUSPENSION

PART NO.	Qty	DESCRIPTION	NOTES
SHOCK ABSORBERS			
BD1400T	2	Nitrogen Gas Shock	Suit OE Height
BM401400	2	40mm Adjustable Shock	
BD1441T	2	Nitrogen Gas Shock	Suit 40mm Lift
BM401441	2	40mm Adjustable Shock	
LEAF SPRINGS			
T64	2	0-300KG Load	Suit LWB Except F77, F87
T64M	2	0-300KG Load	Suit SWB Except F77, F87
COMPONENTS			
TDUK-003	1	Urethane Shackle Bushing Kit	Except F77, F87
TDUB-027	2	U-Bolt Kit	

REPLACEMENT BUSHINGS

PART NO.	Qty	DESCRIPTION	NOTES
QUANTITY PER SHOCK			
TW959	2	Suits Top Pin - Front & Rear	Pin Style Bushing
404702	2	Suits Bottom Eye - Front & Rear	Eyering Bushing

Fitting sheet (located page 243) must be completed when suspension fitted. Failure to comply may affect warranty.



DAIHATSU

ROCKY - F73, F78 (COIL SPRINGS)

08/1998-1999



FRONT SUSPENSION

ESTIMATED LIFT: 40mm

PART NO.	Qty	DESCRIPTION	NOTES
SHOCK ABSORBERS			
FC42019B	2	Foam Cell Shock	
TORSION BARS			
4WTB-0198	1	Replacement Torsion Bars (Pair)	26mm/1093mm
Adjust Torsion bars after fitting shocks - Ensure a minimum of 60mm droop is maintained			

REAR SUSPENSION

PART NO.	Qty	DESCRIPTION	NOTES
SHOCK ABSORBERS			
FC41184	2	Foam Cell Shock	
BM401184	2	40mm Adjustable Shock	
COIL SPRINGS			
TDC066	1	0-300KG Load	40mm Lift (Pair)

REPLACEMENT BUSHINGS

PART NO.	Qty	DESCRIPTION	NOTES
QUANTITY PER SHOCK			
TW959	2	Suit Top Front Pin	Pin Style Bushing
412772	1	Suit Bottom Front Eye	Eyering Bushing
TW959	2	Suit Top Rear Pin	Pin Style Bushing
4W-SPF240-02	1	Suit Bottom Rear Eye	Eyering Style Bushing

All prices exclude freight. Include only permanent accessories & weights when selecting springs. Towing weight is not included.



FRONT SUSPENSION

ESTIMATED LIFT: 40mm

PART NO.	Qty	DESCRIPTION	NOTES
SHOCK ABSORBERS			
FC404500	2	Foam Cell Strut	
BM404500	2	40mm Adjustable Strut	9 Stage Adjustable
COIL SPRINGS			
TDC452	1	40mm Lift Spring (Pair)	Petrol/Diesel/Bar
TDC452HL	1	40mm Lift Spring (Pair)	Petrol/Diesel/Bar/Winch
COMPLETE STRUT ASSEMBLY			
1 Left Hand Side and 1 Right Hand Side strut assembly should be ordered			
MAZ-005-LH	1	BM404500/TDC452	Bar Left Hand Side
MAZ-005-RH	1	BM404500/TDC452	Bar Right Hand Side
MAZ-006-LH	1	BM404500/TDC452HL	Bar/Winch Left Hand Side
MAZ-006-RH	1	BM404500/TDC452HL	Bar/Winch Right Hand Side
MAZ-007-LH	1	FC404500/TDC452	Bar Left Hand Side
MAZ-007-RH	1	FC404500/TDC452	Bar Right Hand Side
MAZ-008-LH	1	FC404500/TDC452HL	Bar/Winch Left Hand Side
MAZ-008-RH	1	FC404500/TDC452HL	Bar/Winch Right Hand Side
ADDITIONAL COMPONENTS			
MAZ-4051	2	Strut Top	Replacement Strut Top
TDCA-003	1	Upper Control Arms (Pair)	Suit Up To 50mm Lift
TDSK-003	1	Bush Kit for TDCA-003	Replacement Bush Kit
TDSK-004	1	Ball Joint Kit for TDCA-003	Replacement Ball Joint

REPLACEMENT BUSHINGS

PART NO.	Qty	DESCRIPTION	NOTES
QUANTITY PER SHOCK			
ADJ00305	1	Suit Bottom Front Eye	Eyering Bonded Bushing
ADJ00312	1	Suit Bottom Rear Eye	Eyering Bonded Bushing

PLEASE NOTE:

Fitment of Tough Dog upper control arms to vehicles that have lifts fitted greater than 50mm may suffer from premature ball joint failure due to longer droop lengths. The use of strut spacers may also effect the performance and longevity of the UCA ball joint due to the limitations of the spherical bearing housing being breached or bound at full suspension droop. There will be no warranty either expressed or implied if the vehicle is used out of legal driving conditions that will include but is not limited to jumping of the vehicle.



FORD
EVEREST - UA1
2015-08/2018



REAR SUSPENSION

ESTIMATED LIFT:

PART NO.	Qty	DESCRIPTION	NOTES
SHOCK ABSORBERS			
FC43013	2	Foam Cell Shock	Suit Up To 40mm Lift
BM403013	2	40mm Adjustable Shock	Suit Up To 40mm Lift
COIL SPRINGS			
TDC453	1	0-300KG Load	40mm Lift
TDC453L	1	CONSTANT 300KG Load	40mm Lift
AIR ASSIST BAGS			
TDAA-004	1	Coil Insert Bag Kit	Suit 40mm Lift
TDAA-014	1	Coil Insert Bag Kit	Suit Standard Height Only

All prices exclude freight. Include only permanent accessories & weights when selecting springs. Towing weight is not included.





FORD
EVEREST - UA2
08/2018 ON



FRONT SUSPENSION

ESTIMATED LIFT: 40mm

PART NO.	Qty	DESCRIPTION	NOTES
SHOCK ABSORBERS			
FC404520	2	Foam Cell Strut	
BM404520	2	40mm Adjustable Strut	9 Stage Adjustable
COIL SPRINGS			
TDC1006	1	40mm Lift Spring (Pair)	Diesel No Accessories
TDC1007	1	40mm Lift Spring (Pair)	Diesel With Bar Or Bar & Winch
COMPLETE STRUT ASSEMBLY			
1 Left Hand Side and 1 Right Hand Side strut assembly should be ordered			
FOR-005-LH	1	BM404520/TDC1006	No Accessories Left Hand Side
FOR-005-RH	1	BM404520/TDC1006	No Accessories Right Hand Side
FOR-006-LH	1	BM404520/TDC1007	Bar or Bar & Winch Left Hand Side
FOR-006-RH	1	BM404520/TDC1007	Bar or Bar & Winch Right Hand Side
FOR-007-LH	1	FC404520/TDC1006	No Accessories Left Hand Side
FOR-007-RH	1	FC404520/TDC1006	No Accessories Right Hand Side
FOR-008-LH	1	FC404520/TDC1007	Bar Or Bar & Winch Left Hand Side
FOR-008-RH	1	FC404520/TDC1007	Bar Or Bar & Winch Right Hand Side
ADDITIONAL COMPONENTS			
FOR-4520	2	Strut Top	Replacement Strut Top
DB170/B	2	Bumpstop and Boot	Replacement Bumpstop and Boot
TDCA-003	1	Upper Control Arms (Pair)	Suit Up To 50mm Lift
TDSK-003	1	Bush Kit for TDCA-003	Replacement Bush Kit
TDSK-004	1	Ball Joint Kit for TDCA-003	Replacement Ball Joint

REPLACEMENT BUSHINGS

PART NO.	Qty	DESCRIPTION	NOTES
QUANTITY PER SHOCK			
ADJ00306	1	Suit Bottom Front Eye	Eyering Bonded Bushing
ADJ00312	1	Suit Bottom Rear Eye	Eyering Bonded Bushing

PLEASE NOTE:

Purchasing the replacement strut top (FOR-4520) will require use of the original bumpstop and boot or purchase of a replacement bumpstop and boot (DB170/B). Contact 4 Way Suspension to discuss.

Fitting sheet (located page 243) must be completed when suspension fitted. Failure to comply may affect warranty.



FORD
EVEREST - UA2
08/2018 ON



REAR SUSPENSION

ESTIMATED LIFT: 40mm

PART NO.	Qty	DESCRIPTION	NOTES
SHOCK ABSORBERS			
FC43013	2	Foam Cell Shock	Suit Up To 40mm Lift
BM403013	2	40mm Adjustable Shock	Suit Up To 40mm Lift
COIL SPRINGS			
TDC453	1	0-300KG Load (Pair)	40mm Lift
TDC453L	1	CONSTANT 300KG Load (Pair)	40mm Lift
AIR ASSIST BAGS			
TDAA-004	1	Coil Insert Bag Kit	Suit 40mm Lift
TDAA-014	1	Coil Insert Bag Kit	Suit Standard Height Only

PLEASE NOTE:

Fitment of Tough Dog upper control arms to vehicles that have lifts fitted greater than 50mm may suffer from premature ball joint failure due to longer droop lengths. The use of strut spacers may also effect the performance and longevity of the UCA ball joint due to the limitations of the spherical bearing housing being breached or bound at full suspension droop. There will be no warranty either expressed or implied if the vehicle is used out of legal driving conditions that will include but is not limited to jumping of the vehicle.





FORD

EXPLORER - UN, UP, UQ

10/1996-2005



FRONT SUSPENSION

No Springs Avail

PART NO.	Qty	DESCRIPTION	NOTES
SHOCK ABSORBERS			
FC41450B	2	Foam Cell Shock	Suit Up To 40mm Lift

REAR SUSPENSION

PART NO.	Qty	DESCRIPTION	NOTES
SHOCK ABSORBERS			
FC41446	2	Foam Cell Shock	Suit Up To 40mm Lift

PLEASE NOTE:

The "Limited" comes standard with (Self Levelling) air shocks. These can be retained or removed as desired. If the (Self Levelling) air shocks are removed, the self levelling indicator light in the dash will turn on and off intermittently. The air hoses should be sealed off and fastened to the chassis for later use if needed.

The air compressor MUST be turned off. The switch is located in the left hand rear inspection console. If further electrical work is required, please consult an Automotive Electrician.

Fitting sheet (located page 243) must be completed when suspension fitted. Failure to comply may affect warranty.



FORD
BRONCO - THIRD GENERATION
03/1981-1989



FRONT SUSPENSION

ESTIMATED LIFT: 30mm

PART NO.	Qty	DESCRIPTION	NOTES
SHOCK ABSORBERS - EXCLUDING QUAD SHOCK			
FC41130B	2	Foam Cell Shock	Suit Up To 30mm Lift
SHOCK ABSORBERS - QUAD SHOCK ONLY			
FC41102B	2	Foam Cell Shock	OE Height - Front Of Axle
FC41130B	2	Foam Cell Shock	OE Height - Rear Of Axle

REAR SUSPENSION

PART NO.	Qty	DESCRIPTION	NOTES
SHOCK ABSORBERS			
FC41379	2	Foam Cell Shock	Suit Up To 30mm Lift

REPLACEMENT BUSHINGS

PART NO.	Qty	DESCRIPTION	NOTES
QUANTITY PER SHOCK			
TW959	2	Suit Front Top Pin	Pin Style Bushing (#1102B ONLY)
404702	1	Suit Front Bottom Eying	Eying Bushing (#1102B ONLY)
404702	1	Suit Rear Top Eying	Eying Bushing
4W-SPF420-04	1	Suit Rear Bottom Eying	Notes

All prices exclude freight. Include only permanent accessories & weights when selecting springs. Towing weight is not included.



FRONT SUSPENSION

ESTIMATED LIFT: 100mm

PART NO.	Qty	DESCRIPTION	NOTES
SHOCK ABSORBERS			
TDR3500	2	Ralph Shock	Suit OE Height ONLY
BMX3500/4	2	45mm Adjustable Shock	Suit 100mm Lift
LEAF SPRINGS			
FS026	2	100mm Lift Spring	Petrol/Diesel/Up To Bar
FS026H	2	100mm Lift Spring	Petrol/Diesel/Bar/Winch
STEERING DAMPERS			
SS5250-XHD	1	XHD Return To Centre Damper	When fitted to OE Height vehicle, low ground clearance occurs.
SV5250	1	9 Stage Adjustable Damper	
ADDITIONAL COMPONENTS			
TDUK-064	1	Urethane Shackle Bushing Kit	Kit Fitted To Springs When Ordered
TDUB-033	2	U-Bolt Kit	
TDPR-250	1	Adjustable Panhard Rod	

REAR SUSPENSION

PART NO.	Qty	DESCRIPTION	NOTES
SHOCK ABSORBERS			
BMX3501	2	45mm Adjustable Shock	OE Height - Front Of Rear Axle
BMX3502	2	45mm Adjustable Shock	OE Height - Rear Of Real Axle
BMX3501/4	2	45mm Adjustable Shock	100mm Lift - Front Of Rear Axle
BMX3502/4	2	45mm Adjustable Shock	100mm Lift - Rear Of Rear Axle
LEAF SPRINGS			
FS027	2	0-500KG Load	100mm Lift
FS027H	2	CONSTANT 500KG Load	100mm Lift
ADDITIONAL COMPONENTS			
TDUK-064	1	Urethane Shackle Bushing Kit	Kit Fitted To Springs When Ordered
TDUB-034	2	U-Bolt Kit	

REPLACEMENT BUSHINGS

PART NO.	Qty	DESCRIPTION	NOTES
QUANTITY PER SHOCK			
TW038-16	1	Suit Top Mount	Eyering Bonded Bushing
TW038-12	1	Suit Bottom Mount	Eyering Bonded Bushing

Fitting sheet (located page 243) must be completed when suspension fitted. Failure to comply may affect warranty.



FORD
F250
2016-2020



FRONT SUSPENSION

ESTIMATED LIFT: OE HEIGHT

PART NO.	Qty	DESCRIPTION	NOTES
SHOCK ABSORBERS			
BMX3507	2	45mm Adjustable Shock	

REAR SUSPENSION

PART NO.	Qty	DESCRIPTION	NOTES
SHOCK ABSORBERS			
BMX3508	2	45mm Adjustable Shock	
AIR ASSIST BAGS			
TDAA-129	1	Coil Insert Bag Kit	Suit Standard Height Only

All prices exclude freight. Include only permanent accessories & weights when selecting springs. Towing weight is not included.





FRONT SUSPENSION

ESTIMATED LIFT: 40mm

PART NO.	Qty	DESCRIPTION	NOTES
SHOCK ABSORBERS			
FC42051B	2	Foam Cell Shock	Suit Up To 40mm Lift
TDSK-020	1	Shock Mount Strengthening Kit	Top Pin Mount Bracket
Please Note: Failure to fit TDSK-020 will cause top mount failure. Fitting instructions at toughdog.com.au			
TORSION BARS			
4WTB-1546	1	Replacement Torsion Bars (Pair)	26mm/926mm
Adjust Torsion bars after fitting shocks - Ensure a minimum of 60mm droop is maintained			

REAR SUSPENSION

PART NO.	Qty	DESCRIPTION	NOTES
SHOCK ABSORBERS			
FC41232	2	Foam Cell Shock	Suit Up To 40mm Lift
BM401232	2	40mm Adjustable Shock	Suit Up To 40mm Lift
LEAF SPRINGS			
FS365	2	0-300KG Load	40mm Lift
FS367	2	CONSTANT 300KG Load	40mm Lift
COMPONENTS			
TDUK-034	1	Urethane Bushing Kit	
TDUB-005	2	U-Bolt Kit	

REPLACEMENT BUSHINGS

PART NO.	Qty	DESCRIPTION	NOTES
QUANTITY PER SHOCK			
TW959 + TW961	1 ea	Suit Top Front Pin	Pin Style Bushing
4W-SPF420-05	1	Suit Bottom Front Eye	Suit Body # 42057 ONLY
4W-SPF420-02	1	Suit Bottom Front Eye	Suit Body # 42051 ONLY
ADJ00191	1	Suit Top Rear Eying	Suit Foam Cell Shocks
4W-SPF420-02	1	Suit Bottom Rear Eying	
230100	1	Suit Top Rear Eying	Suit 40mm Adjustable Shocks
230002	1	Suit Bottom Rear Eying	

Fitting sheet (located page 243) must be completed when suspension fitted. Failure to comply may affect warranty.



FRONT SUSPENSION

ESTIMATED LIFT: 45mm

PART NO.	Qty	DESCRIPTION	NOTES
SHOCK ABSORBERS			
FC42051B	2	Foam Cell Shock	Suit Up To 40mm Lift
TDSK-020	1	Shock Mount Strengthening Kit	Top Pin Mount Bracket
Please Note: Failure to fit TDSK-020 will cause top mount failure. Fitting instructions at toughdog.com.au			
TORSION BARS			
4WTB-1440	1	Replacement Torsion Bars (Pair)	27mm/1028mm
Adjust Torsion bars after fitting shocks - Ensure a minimum of 60mm droop is maintained			

REAR SUSPENSION

PART NO.	Qty	DESCRIPTION	NOTES
SHOCK ABSORBERS			
FC41232	2	Foam Cell Shock	Suit Up To 45mm Lift
BM401232	2	40mm Adjustable Shock	Suit Up To 45mm Lift
LEAF SPRINGS			
1 Left Hand Side and 1 Right Hand Side leaf spring pack should be ordered			
FS368C-LH	1	0-300KG Load	45mm Lift Left Hand Side
FS368C-RH	1	0-300KG Load	45mm Lift Right Hand Side
FS368L-LH	1	CONSTANT 300KG Load	45mm Lift Left Hand Side
FS368L-RH	1	CONSTANT 300KG Load	45mm Lift Right Hand Side
COMPONENTS			
TDUK-069	1	Urethane Shackle Bushing Kit	
TDUB-040	2	U-Bolt Kit	Suit FS368C-LH & -RH Only
TDUB-039	2	U-Bolt Kit	Suit FS368L-LH & -RH Only
TDGS-386/1	1	Greasable Shackle Kit	
TDGP-668	1	Greasable Pin Kit	
AIR ASSIST BAGS			
TDAA-101	1	Bellows Bag Kit	Suit 45mm Lift
TDAA-117	1	Bellows Bag Kit	Suit Standard Height Only

REPLACEMENT BUSHINGS

PART NO.	Qty	DESCRIPTION	NOTES
QUANTITY PER SHOCK			
TW959 + TW961	1 ea	Suit Top Front Pin	Pin Style Bushing
412772	1	Suit Bottom Front Eye	Eyering Bushing
ADJ00191	1	Suit Top Rear Eyering	
4W-SPF420-02	1	Suit Bottom Rear Eyering	Suit Foam Cell Shocks
230100	1	Suit Top Rear Eyering	
230002	1	Suit Bottom Rear Eyering	Suit 40mm Adjustable Shocks



FORD

RANGER - PX & PXII

11/2011-08/2018



FRONT SUSPENSION

ESTIMATED LIFT: 40mm

PART NO.	Qty	DESCRIPTION	NOTES
SHOCK ABSORBERS			
FC404500	2	Foam Cell Strut	
BM404500	2	40mm Adjustable Strut	9 Stage Adjustable
COIL SPRINGS			
TDC451	1	40mm Lift Spring (Pair)	Petrol/Diesel/Bar
TDC451HL	1	40mm Lift Spring (Pair)	Petrol/Diesel/Bar/Winch
COMPLETE STRUT ASSEMBLY			
1 Left Hand Side and 1 Right Hand Side strut assembly should be ordered			
MAZ-001-LH	1	BM404500/TDC451	Bar Left Hand Side
MAZ-001-RH	1	BM404500/TDC451	Bar Right Hand Side
MAZ-002-LH	1	BM404500/TDC451HL	Bar/Winch Left Hand Side
MAZ-002-RH	1	BM404500/TDC451HL	Bar/Winch Right Hand Side
MAZ-003-LH	1	FC404500/TDC451	Bar Left Hand Side
MAZ-003-RH	1	FC404500/TDC451	Bar Right Hand Side
MAZ-004-LH	1	FC404500/TDC451HL	Bar/Winch Left Hand Side
MAZ-004-RH	1	FC404500/TDC451HL	Bar/Winch Right Hand Side
COMPONENTS			
MAZ-4051	2	Strut Top	Replacement Strut Top
TDCA-003	1	Upper Control Arms (Pair)	Suit Up To 50mm Lift
TDSK-003	1	Bush Kit for TDCA-003	Replacement Bush Kit
TDSK-004	1	Ball Joint Kit for TDCA-003	Replacement Ball Joint

REPLACEMENT BUSHINGS

PART NO.	Qty	DESCRIPTION	NOTES
QUANTITY PER SHOCK			
ADJ00305	1	Suit Bottom Front Eye	Eyering Bonded Bushing
ADJ00191	1	Suit Top Rear Eyering	
4W-SPF420-02	1	Suit Bottom Rear Eyering	Suit Foam Cell Shocks
230100	1	Suit Top Rear Eyering	
230002	1	Suit Bottom Rear Eyering	Suit 40mm Adjustable Shocks

PLEASE NOTE:

Fitment of Tough Dog upper control arms to vehicles that have lifts fitted greater than 50mm may suffer from premature ball joint failure due to longer droop lengths. The use of strut spacers may also effect the performance and longevity of the UCA ball joint due to the limitations of the spherical bearing housing being breached or bound at full suspension droop. There will be no warranty either expressed or implied if the vehicle is used out of legal driving conditions that will include but is not limited to jumping of the vehicle.

Fitting sheet (located page 243) must be completed when suspension fitted. Failure to comply may affect warranty.



FORD

RANGER - PX & PXII

11/2011-08/2018



REAR SUSPENSION

ESTIMATED LIFT: 40mm

PART NO.	Qty	DESCRIPTION	NOTES
SHOCK ABSORBERS			
FC41232	2	Foam Cell Shock	Suit Up To 40mm Lift
BM401232	2	40mm Adjustable Shock	Suit Up To 40mm Lift
LEAF SPRINGS			
FS369C	2	0-300KG Load	40mm Lift
FS369L	2	CONSTANT 300KG Load	40mm Lift
FS369LL	2	CONSTANT 500KG Load	40mm Lift
COMPONENTS			
TDUK-070	1	Urethane Shackle Bushing Kit	
TDUB-039	2	U-Bolt Kit	Suit FS369L & LL Spring
TDUB-040	2	U-Bolt Kit	Suit FS369C Spring Only
TDGS-390	1	Greasable Shackle Kit	
TDGP-668	1	Greasable Pin Kit	
TDSP-007	1	Transmission Spacer Kit	Must be fitted to ALL Lift Kits
AIR ASSIST BAGS			
TDAA-102	1	Bellows Bag Kit	Suit 40mm Lift
TDAA-116	1	Bellows Bag Kit	Suit Standard Height ONLY

All prices exclude freight. Include only permanent accessories & weights when selecting springs. Towing weight is not included.



FORD
RANGER - PXIII
08/2018 ON



FRONT SUSPENSION

ESTIMATED LIFT: 40mm

PART NO.	Qty	DESCRIPTION	NOTES
SHOCK ABSORBERS			
FC404520	2	Foam Cell Strut	
BM404520	2	40mm Adjustable Strut	9 Stage Adjustable
COIL SPRINGS			
TDC455	1	40mm Lift Spring (Pair)	Petrol/Diesel/Bar
TDC455HL	1	40mm Lift Spring (Pair)	Petrol/Diesel/Bar/Winch
COMPLETE STRUT ASSEMBLY			
1 Left Hand Side and 1 Right Hand Side strut assembly should be ordered			
FOR-001-LH	1	BM404520/TDC455	Bar Left Hand Side
FOR-001-RH	1	BM404520/TDC455	Bar Right Hand Side
FOR-002-LH	1	BM404520/TDC455HL	Bar/Winch Left Hand Side
FOR-002-RH	1	BM404520/TDC455HL	Bar/Winch Right Hand Side
FOR-003-LH	1	FC404520/TDC455	Bar Left Hand Side
FOR-003-RH	1	FC404520/TDC455	Bar Right Hand Side
FOR-004-LH	1	FC404520/TDC455HL	Bar/Winch Left Hand Side
FOR-004-RH	1	FC404520/TDC455HL	Bar/Winch Right Hand Side
COMPONENTS			
FOR-4520	2	Strut Top	Replacement Strut Top
DB170/B	2	Bumpstop and Boot	Replacement Bumpstop and Boot
TDCA-003	1	Upper Control Arms (Pair)	Suit Up To 50mm Lift
TDSK-003	1	Bush Kit for TDCA-003	Replacement Bush Kit
TDSK-004	1	Ball Joint Kit for TDCA-003	Replacement Ball Joint

PLEASE NOTE:

Purchasing the replacement strut top (FOR-4520) will require use of the original bumpstop and boot or purchase of a replacement bumpstop and boot (DB170/B). Contact 4 Way Suspension to discuss.

PLEASE NOTE:

Fitment of Tough Dog upper control arms to vehicles that have lifts fitted greater than 50mm may suffer from premature ball joint failure due to longer droop lengths. The use of strut spacers may also effect the performance and longevity of the UCA ball joint due to the limitations of the spherical bearing housing being breached or bound at full suspension droop. There will be no warranty either expressed or implied if the vehicle is used out of legal driving conditions that will include but is not limited to jumping of the vehicle.

Fitting sheet (located page 243) must be completed when suspension fitted. Failure to comply may affect warranty.



FORD

RANGER - PXIII

08/2018 ON



REAR SUSPENSION

ESTIMATED LIFT: 40mm

PART NO.	Qty	DESCRIPTION	NOTES
SHOCK ABSORBERS			
FC41232	2	Foam Cell Shock	Suit Up To 40mm Lift
BM401232	2	40mm Adjustable Shock	Suit Up To 40mm Lift
LEAF SPRINGS			
FS369C	2	0-300KG Load	40mm Lift
FS369L	2	CONSTANT 300KG Load	40mm Lift
FS369LL	2	CONSTANT 500KG Load	40mm Lift
COMPONENTS			
TDUK-070	1	Urethane Shackle Bushing Kit	
TDUB-039	2	U-Bolt Kit	Suit FS369L & LL Spring
TDUB-040	2	U-Bolt Kit	Suit FS369C Spring Only
TDGS-390	1	Greasable Shackle Kit	
TDGP-668	1	Greasable Pin Kit	
TDSP-007	1	Transmission Spacer Kit	Must be fitted to All Lift Kits
AIR ASSIST BAGS			
TDAA-102	1	Bellows Bag Kit	Suit 40mm Lift
TDAA-116	1	Bellows Bag Kit	Suit Standard Height Only

REPLACEMENT BUSHINGS

PART NO.	Qty	DESCRIPTION	NOTES
QUANTITY PER SHOCK			
ADJ00306	1	Suit Bottom Front Eye	Eyering Bonded Bushing
ADJ00191	1	Suit Top Rear Eyering	Suit Foam Cell Shocks
4W-SPF420-02	1	Suit Bottom Rear Eyering	
230100	1	Suit Top Rear Eyering	Suit 40mm Adjustable Shocks
230002	1	Suit Bottom Rear Eyering	

All prices exclude freight. Include only permanent accessories & weights when selecting springs. Towing weight is not included.



FORD
RANGER - PXIII RAPTOR ONLY
08/2018 ON



FRONT SUSPENSION

ESTIMATED LIFT: 40mm

PART NO.	Qty	DESCRIPTION	NOTES
COIL SPRINGS			
TDC1022	1	OE Height (Pair)	Bar/Winch ONLY

REAR SUSPENSION

PART NO.	Qty	DESCRIPTION	NOTES
COIL SPRINGS			
TDC1023	1	150-300KG Load (Pair)	OE Height ONLY

PLEASE NOTE:

The Ford Ranger Raptor features shock absorbers from Fox Suspension, which are internal bypass style shock absorbers, and are therefore height sensitive in their ride control. When additional accessories like front steel bars, or rear tub accessories are fitted, the ride height of the vehicle is altered, which in turn alters the performance of the shock absorber.

Tough Dog coils are designed to return the vehicle to the original ride height to maintain the ride quality, and should therefore only be fitted in the event that the appropriate level of accessory or other permanent load is present to ensure that the vehicle's ride is not adversely affected.

Fitting sheet (located page 243) must be completed when suspension fitted. Failure to comply may affect warranty.



FRONT SUSPENSION

ESTIMATED LIFT: 45mm

PART NO.	Qty	DESCRIPTION	NOTES
SHOCK ABSORBERS			
FC42019B	2	Foam Cell Shock	Suit Up To 45mm Lift
TORSION BARS			
4WTB-1559	1	Replacement Torsion Bars (Pair)	30mm/1145mm
Adjust Torsion bars after fitting shocks - Ensure a minimum of 60mm droop is maintained			

REAR SUSPENSION

PART NO.	Qty	DESCRIPTION	NOTES
SHOCK ABSORBERS			
BD1382T	2	Nitrogen Gas Shock	
FC41382	2	Foam Cell Shock	Suit OE Height
BM401382	2	40mm Adjustable Shock	
BD1388T	2	Nitrogen Gas Shock	
FC41388	2	Foam Cell Shock	Suit 45mm Lift
BM401388	2	40mm Adjustable Shock	
LEAF SPRINGS			
FS213	2	0-300KG Load	45mm Lift
FS213H	2	CONSTANT 300KG Load	45mm Lift
COMPONENTS			
TDUK-065	1	Urethane Shackle Bushing Kit	
TDUB-039	2	U-Bolt Kit	
TDGS-386	1	Greasable Shackle Kit	
TDGP-668	1	Greasable Pin Kit	

REPLACEMENT BUSHINGS

PART NO.	Qty	DESCRIPTION	NOTES
QUANTITY PER SHOCK			
TW959	2	Suit Top Front Pin	Pin Style Bushing
412772	1	Suit Bottom Front Eying	Eying Bushing
404702	2	Suit Top & Bottom Rear Eying	Eying Bushing



FRONT SUSPENSION

ESTIMATED LIFT: 30mm

PART NO.	Qty	DESCRIPTION	NOTES
SHOCK ABSORBERS			
FC42019B	2	Foam Cell Shock	Suits Up To 30mm Lift
TORSION BARS			
4WTB-1559	1	Replacement Torsion Bars (Pair)	30mm/1145mm
Adjust Torsion bars after fitting shocks - Ensure a minimum of 60mm droop is maintained			

REAR SUSPENSION

PART NO.	Qty	DESCRIPTION	NOTES
SHOCK ABSORBERS			
FC41460	2	Foam Cell Shock	Suit Up To 30mm Lift
BM401460	2	40mm Adjustable Shock	Suit Up To 30mm Lift
COIL SPRINGS			
TDC045	1	0-300KG Load (Pair)	30mm Lift
TDC047	1	CONSTANT 300KG Load (Pair)	30mm Lift

REPLACEMENT BUSHINGS

PART NO.	Qty	DESCRIPTION	NOTES
QUANTITY PER SHOCK			
TW959	2	Suit Top Front Pin	Pin Style Bushing
412772	1	Suit Bottom Front Eye	Eyering Bushing
TW959	2	Suit Top Rear Pin	Pin Style Bushing
TW038-16	1	Suit Bottom Rear Eyering	Eyering Bushing

Fitting sheet (located page 243) must be completed when suspension fitted. Failure to comply may affect warranty.



FRONT SUSPENSION

ESTIMATED LIFT: 40mm

PART NO.	Qty	DESCRIPTION	NOTES
SHOCK ABSORBERS			
FC42019B	2	Foam Cell Shock	Suits Up To 30mm Lift
TORSION BARS			
4WTB-1559	1	Replacement Torsion Bars (Pair)	30mm/1145mm
Adjust Torsion bars after fitting shocks - Ensure a minimum of 60mm droop is maintained			

REAR SUSPENSION

PART NO.	Qty	DESCRIPTION	NOTES
SHOCK ABSORBERS			
BD1382T	2	Nitrogen Gas Shock	Suit Up TO 40mm Lift
FC41382	2	Foam Cell Shock	
BM401382	2	40mm Adjustable Shock	
LEAF SPRINGS			
FS213	2	0-300KG Load	40mm Lift
FS213H	2	CONSTANT 300KG Load	40mm Lift
COMPONENTS			
TDUK-065	1	Urethane Shackle Bushing Kit	
TDUB-017	2	U-Bolt Kit	
TDGS-386	1	Greasable Shackle Kit	
TDGP-668	1	Greasable Pin Kit	
TDSP-025	1	Handbrake Relocation Kit	

REPLACEMENT BUSHINGS

PART NO.	Qty	DESCRIPTION	NOTES
QUANTITY PER SHOCK			
TW959	2	Suit Top Front Pin	Pin Style Bushing
412772	1	Suit Bottom Front Eying	Eying Bushing
404702	2	Suit Top & Bottom Rear Eying	Eying Bushing



FRONT SUSPENSION

ESTIMATED LIFT: 40mm

PART NO.	Qty	DESCRIPTION	NOTES
SHOCK ABSORBERS			
FC42019B	2	Foam Cell Shock	Suits Up To 40mm Lift
TORSION BARS			
4WTB-1559	1	Replacement Torsion Bars (Pair)	40mm/1145mm
Adjust Torsion bars after fitting shocks - Ensure a minimum of 60mm droop is maintained			

REAR SUSPENSION

PART NO.	Qty	DESCRIPTION	NOTES
SHOCK ABSORBERS			
FC41200	2	Foam Cell Shock	Check Mounts before ordering
BM401200	2	40mm Adjustable Shock	Suit Eye/Eye Vehicles
FC41201B	2	Foam Cell Shock	Check Mounts before ordering
BM401201	2	40mm Adjustable Shock	Suit Pin/Eye Vehicles
COIL SPRINGS			
TDC290	1	0-300KG Load (Pair)	OE Height (10/95-99 ONLY)
TDC267	1	0-300KG Load (Pair)	40mm Lift
TDC267H	1	CONSTANT 300KG Load (Pair)	40mm Lift

Fitting sheet (located page 243) must be completed when suspension fitted. Failure to comply may affect warranty.



FRONT SUSPENSION

ESTIMATED LIFT: 45mm

PART NO.	Qty	DESCRIPTION	NOTES
SHOCK ABSORBERS			
BD2057T	2	Nitrogen Gas Shock	Suit Up To 45mm Lift
FC42057B	2	Foam Cell Shock	Suit Up To 45mm Lift
TORSION BARS			
4WTB-1546	1	Replacement Torsion Bars (Pair)	26mm/926mm
Adjust Torsion bars after fitting shocks - Ensure a minimum of 60mm droop is maintained			

REAR SUSPENSION

PART NO.	Qty	DESCRIPTION	NOTES
SHOCK ABSORBERS			
BD1382T	2	Nitrogen Gas Shock	
FC41382	2	Foam Cell Shock	Suit OE Height
BM401382	2	40mm Adjustable Shock	
BD1388T	2	Nitrogen Gas Shock	
FC41388	2	Foam Cell Shock	Suit 45mm Lift
BM401388	2	40mm Adjustable Shock	
LEAF SPRINGS			
FS113	2	0-300KG Load	45mm Lift
FS113H	2	CONSTANT 300KG Load	45mm Lift
COMPONENTS			
TDUK-004	1	Urethane Shackle Bushing Kit	
TDUB-006	2	U-Bolt Kit	
TDGP-668	1	Greasable Pin Kit	

REPLACEMENT BUSHINGS

PART NO.	Qty	DESCRIPTION	NOTES
QUANTITY PER SHOCK			
TW959	2	Suit Top Front Pin	Pin Style Bushing
412772	1	Suit Bottom Front Eye	Eyering Bushing
404702	2	Suit Top & Bottom Rear Eye	Eyering Bushing



FRONT SUSPENSION

ESTIMATED LIFT: 45mm

PART NO.	Qty	DESCRIPTION	NOTES
SHOCK ABSORBERS			
BD2057T	2	Nitrogen Gas Shock	Suit Up To 45mm Lift
FC42057B	2	Foam Cell Shock	Suit Up To 45mm Lift
TORSION BARS			
4WTB-1548	1	Replacement Torsion Bars (Pair)	26mm/997mm
Adjust Torsion bars after fitting shocks - Ensure a minimum of 60mm droop is maintained			

REAR SUSPENSION

PART NO.	Qty	DESCRIPTION	NOTES
SHOCK ABSORBERS			
BD1105T	2	Nitrogen Gas Shock	
FC41105	2	Foam Cell Shock	Suit OE Height
BM401105	2	40mm Adjustable Shock	
BD1106TB	2	Nitrogen Gas Shock	
FC41106	2	Foam Cell Shock	Suit 45mm Lift
BM401106	2	40mm Adjustable Shock	
LEAF SPRINGS			
FS113	2	0-300KG Load	45mm Lift
FS113H	2	CONSTANT 300KG Load	45mm Lift
COMPONENTS			
TDUK-004	1	Urethane Shackle Bushing Kit	
TDUB-006	2	U-Bolt Kit	
TDGP-668	1	Greasable Pin Kit	

REPLACEMENT BUSHINGS

PART NO.	Qty	DESCRIPTION	NOTES
QUANTITY PER SHOCK			
TW959	2	Suit Top Front Pin	Pin Style Bushing
412772	1	Suit Bottom Front Eye	Eyering Bushing
TW959	2	Suit Top Rear Pin	Pin Style Bushing
404702	1	Suit Bottom Rear Eye	Eyering Bushing



HOLDEN

JACKAROO, MONTEREY - UBS25, 26, 69, 73
05/1992-1998 & 09/1998-2004



FRONT SUSPENSION

ESTIMATED LIFT: 40mm

PART NO.	Qty	DESCRIPTION	NOTES
SHOCK ABSORBERS			
FC42019B	2	Foam Cell Shock	Suit Up To 40mm Lift
TORSION BARS			
4WTB-1549	1	Replacement Torsion Bars (Pair)	29.3mm/1220mm
Adjust Torsion bars after fitting shocks - Ensure a minimum of 60mm droop is maintained			

REAR SUSPENSION

PART NO.	Qty	DESCRIPTION	NOTES
SHOCK ABSORBERS			
FC41200	2	Foam Cell Shock	Suit Up To 40mm Lift
BM401200	2	40mm Adjustable Shock	Suit Up To 40mm Lift
COIL SPRINGS			
TDC267	1	0-300KG Load (Pair)	40mm Lift Suit UBS 25, 69
TDC267H	1	CONSTANT 300KG Load (Pair)	
TDC267HH	1	CONSTANT 500KG Load (Pair)	
TDC267H	1	0-300KG Load (Pair)	40mm Lift Suit UBS 26, 73 WIDE BODY
TDC267HH	1	CONSTANT 300KG Load (Pair)	

REPLACEMENT BUSHINGS

PART NO.	Qty	DESCRIPTION	NOTES
QUANTITY PER SHOCK			
TW959	2	Suit Top Front Pin	Pin Style Bushing
412772	1	Suit Bottom Front Eye	Eyering Bushing
415024	1	Suit Bottom Rear Eye	Eyering Bushing

All prices exclude freight. Include only permanent accessories & weights when selecting springs. Towing weight is not included.



FRONT SUSPENSION

ESTIMATED LIFT: 40mm

PART NO.	Qty	DESCRIPTION	NOTES
TORSION BARS			
4WTB-1536	1	Replacement Torsion Bars (Pair)	26mm/927mm (01/81-83 ONLY)
4WTB-1546	1	Replacement Torsion Bars (Pair)	26mm/926mm (83-88 ONLY)
Adjust Torsion bars after fitting shocks - Ensure a minimum of 60mm droop is maintained			

REAR SUSPENSION

PART NO.	Qty	DESCRIPTION	NOTES
SHOCK ABSORBERS			
BD1382T	2	Nitrogen Gas Shock	Suit OE Height
FC41382	2	Foam Cell Shock	
BM401382	2	40mm Adjustable Shock	
BD1388T	2	Nitrogen Gas Shock	Suit 40mm Lift
FC41388	2	Foam Cell Shock	
BM401388	2	40mm Adjustable Shock	
LEAF SPRINGS			
FS113	2	0-300KG Load	40mm Lift
FS113H	2	CONSTANT 300KG Load	40mm Lift
FS113HM	2	CONSTANT 500KG Load	40mm Lift
ADDITIONAL COMPONENTS			
TDUK-004	1	Urethane Shackle Bushing Kit	
TDUB-006	2	U-Bolt Kit	
TDGS-386	1	Greasable Shackle Kit	
TDGP-668	1	Greasable Pin Kit	

REPLACEMENT BUSHINGS

PART NO.	Qty	DESCRIPTION	NOTES
QUANTITY PER SHOCK			
404702	2	Suit Top & Bottom Rear Eye	Eyering Bushing

Fitting sheet (located page 243) must be completed when suspension fitted. Failure to comply may affect warranty.



HOLDEN

RODEO - TFS17, 54, 55, TFS25, 77
08/1988-2003



FRONT SUSPENSION

ESTIMATED LIFT: 40mm

PART NO.	Qty	DESCRIPTION	NOTES
SHOCK ABSORBERS			
BD2057T	2	Nitrogen Gas Shock	Suit Up To 40mm Lift
TORSION BARS			
4WTB-1548	1	Replacement Torsion Bars (Pair)	26mm/997mm - 36mm Spline
4WTB-1566	1	Replacement Torsion Bars (Pair)	27mm/998mm - 33mm Spline
Check Spline & Diameter prior to ordering			
Adjust Torsion bars after fitting shocks - Ensure a minimum of 60mm droop is maintained			

REAR SUSPENSION

PART NO.	Qty	DESCRIPTION	NOTES
SHOCK ABSORBERS			
BD1382T	2	Nitrogen Gas Shock	
FC41382	2	Foam Cell Shock	Suit OE Height
BM401382	2	40mm Adjustable Shock	
BD1388T	2	Nitrogen Gas Shock	
FC41388	2	Foam Cell Shock	Suit 40mm Lift
BM401388	2	40mm Adjustable Shock	
LEAF SPRINGS			
Check Number of Leaves - Rare special editions have heavier factory leaf packs			
FS113	2	0-300KG Load	40mm Lift
FS113H	2	CONSTANT 300KG Load	40mm Lift
FS113HM	2	CONSTANT 500KG Load	40mm Lift
ADDITIONAL COMPONENTS			
TDUK-065	1	Urethane Shackle Bushing Kit	
TDUB-005	2	U-Bolt Kit	
TDGS-386	1	Greasabe Shackle Kit	
TDGP-668	1	Greasable Pin Kit	

REPLACEMENT BUSHINGS

PART NO.	Qty	DESCRIPTION	NOTES
QUANTITY PER SHOCK			
TW959	2	Suit Top Front Pin	Pin Style Bushing
412772	1	Suit Bottom Front Eye	Eyering Bushing
404702	2	Suit Top & Bottom Rear Eye	Eyering Bushing

All prices exclude freight. Include only permanent accessories & weights when selecting springs. Towing weight is not included.



FRONT SUSPENSION

ESTIMATED LIFT: 45mm

PART NO.	Qty	DESCRIPTION	NOTES
SHOCK ABSORBERS			
FC42019B	2	Foam Cell Shock	Suit Up To 45mm Lift
TORSION BARS			
4WTB-1559	1	Replacement Torsion Bars (Pair)	30mm/1145mm
Adjust Torsion bars after fitting shocks - Ensure a minimum of 60mm droop is maintained			

REAR SUSPENSION

PART NO.	Qty	DESCRIPTION	NOTES
SHOCK ABSORBERS			
BD1382T	2	Nitrogen Gas Shock	
FC41382	2	Foam Cell Shock	Suit OE Height
BM401382	2	40mm Adjustable Shock	
BD1388T	2	Nitrogen Gas Shock	
FC41388	2	Foam Cell Shock	Suit 45mm Lift
BM401388	2	40mm Adjustable Shock	
LEAF SPRINGS			
FS213	2	0-300KG Load	45mm Lift
FS213H	2	CONSTANT 300KG Load	45mm Lift
ADDITIONAL COMPONENTS			
TDUK-065	1	Urethane Shackle Bushing Kit	
TDUB-039	2	U-Bolt Kit	
TDGS-386	1	Greasable Shackle Kit	
TDGP-668	1	Greasable Pin Kit	
AIR ASSIST BAGS			
TDAA-103	1	Bellows Bag Kit	Suit 45mm Lift

REPLACEMENT BUSHINGS

PART NO.	Qty	DESCRIPTION	NOTES
QUANTITY PER SHOCK			
TW959	2	Suit Top Front Pin	Pin Style Bushing
412772	1	Suit Bottom Front Eye	Eyering Bushing
404702	2	Suit Top & Bottom Rear Eye	Eyering Bushing

Fitting sheet (located page 243) must be completed when suspension fitted. Failure to comply may affect warranty.



THIS PAGE IS INTENTIONALLY BLANK



HOLDEN

COLORADO - RG, MMU142, GM1700

07/2012-06/2016



FRONT SUSPENSION

ESTIMATED LIFT: 40mm

PART NO.	Qty	DESCRIPTION	NOTES
SHOCK ABSORBERS			
FC404200	2	Foam Cell Strut	
BM404200	2	40mm Adjustable Strut	9 Stage Adjustable
COIL SPRINGS			
TDC270	1	40mm Lift Spring (Pair)	Petrol/Diesel/Bar
TDC974	1	40mm Lift Spring (Pair)	Petrol/Diesel/Bar/Winch
COMPLETE STRUT ASSEMBLY			
HOL-001	2	BM404200/TDC270	Petrol/Diesel/Bar
HOL-002	2	BM404200/TDC974	Petrol/Diesel/Bar/Winch
HOL-003	2	FC404200/TDC270	Petrol/Diesel/Bar
HOL-004	2	FC404200/TDC974	Petrol/Diesel/Bar/Winch
ADDITIONAL COMPONENTS			
TOY-1081	2	Strut Top	Replacement Strut Top

REPLACEMENT BUSHINGS

PART NO.	Qty	DESCRIPTION	NOTES
QUANTITY PER SHOCK			
ADJ300/40A	1	Suit Bottom Front Eye	Eyering Bonded Bushing
404702	2	Suit Top & Bottom Rear Eye	Eyering Bushing

Fitting sheet (located page 243) must be completed when suspension fitted. Failure to comply may affect warranty.



HOLDEN

COLORADO - RG, MMU142, GM1700 07/2012-06/2016



REAR SUSPENSION

ESTIMATED LIFT: 40mm

PART NO.	Qty	DESCRIPTION	NOTES
SHOCK ABSORBERS			
BD1382T	2	Nitrogen Gas Shock	Suit Up To 40mm Lift
FC41382	2	Foam Cell Shock	Suit Up To 40mm Lift
BM401382	2	40mm Adjustable Shock	Suit Up To 40mm Lift
LEAF SPRINGS			
FS214C	2	0-300KG Load	40mm Lift
FS214L	2	CONSTANT 300KG Load	40mm Lift
FS214LL	2	CONSTANT 500KG Load	40mm Lift
ADDITIONAL COMPONENTS			
TDUK-071	1	Urethane Shackle Bushing Kit	
TDUB-016	2	U-Bolt Kit	
TDGS-391	1	Greasable Shackle Kit	
TDGP-668	1	Greasable Pin Kit	
AIR ASSIST BAGS			
TDAA-104	1	Bellows Bag Kit	Suit 40mm Lift
TDAA-118	1	Bellows Bag Kit	Suit Standard Height Only

All prices exclude freight. Include only permanent accessories & weights when selecting springs. Towing weight is not included.





HOLDEN

COLORADO - RG, MMU142, GM1700

06/2016 ON



FRONT SUSPENSION

ESTIMATED LIFT: 40mm

PART NO.	Qty	DESCRIPTION	NOTES
SHOCK ABSORBERS			
FC404200	2	Foam Cell Strut	
BM404200	2	40mm Adjustable Strut	9 Stage Adjustable
COIL SPRINGS			
TDC270	1	40mm Lift Spring (Pair)	Petrol/Diesel/Bar
TDC974	1	40mm Lift Spring (Pair)	Petrol/Diesel/Bar/Winch
COMPLETE STRUT ASSEMBLY			
HOL-001	2	BM404200/TDC270	Petrol/Diesel/Bar
HOL-002	2	BM404200/TDC974	Petrol/Diesel/Bar/Winch
HOL-003	2	FC404200/TDC270	Petrol/Diesel/Bar
HOL-004	2	FC404200/TDC974	Petrol/Diesel/Bar/Winch
ADDITIONAL COMPONENTS			
TOY-1081	2	Strut Top	Replacement Strut Top

REPLACEMENT BUSHINGS

PART NO.	Qty	DESCRIPTION	NOTES
QUANTITY PER SHOCK			
ADJ300/40A	1	Suit Bottom Front Eye	Eyering Bonded Bushing
404702	2	Suit Top & Bottom Rear Eye	Eyering Bushing

Fitting sheet (located page 243) must be completed when suspension fitted. Failure to comply may affect warranty.



HOLDEN

**COLORADO - RG, MMU142, GM1700
06/2016 ON**



REAR SUSPENSION

ESTIMATED LIFT: 40mm

PART NO.	Qty	DESCRIPTION	NOTES
SHOCK ABSORBERS			
BD1382T	2	Nitrogen Gas Shock	Suit Up To 40mm Lift
FC41382	2	Foam Cell Shock	Suit Up To 40mm Lift
BM401382	2	40mm Adjustable Shock	Suit Up To 40mm Lift
LEAF SPRINGS			
FS214C	2	0-300KG Load	40mm Lift
FS214L	2	CONSTANT 300KG Load	40mm Lift
FS214LL	2	CONSTANT 500KG Load	40mm Lift
ADDITIONAL COMPONENTS			
TDUK-071	1	Urethane Shackle Bushing Kit	
TDUB-016	2	U-Bolt Kit	
TDGS-391	1	Greasable Shackle Kit	
TDGP-668	1	Greasable Pin Kit	
TDSK-021	1	Handbrake Relocation Kit	Required for MY17 (06/16) On
AIR ASSIST BAGS			
TDAA-104	1	Bellows Bag Kit	Suit 40mm Lift
TDAA-118	1	Bellows Bag Kit	Suit Standard Height Only

All prices exclude freight. Include only permanent accessories & weights when selecting springs. Towing weight is not included.



HOLDEN

COLORADO 7 / TRAILBLAZER

12/2012 ON



FRONT SUSPENSION

ESTIMATED LIFT: 40mm

PART NO.	Qty	DESCRIPTION	NOTES
SHOCK ABSORBERS			
FC404200	2	Foam Cell Strut	
BM404200	2	40mm Adjustable Strut	9 Stage Adjustable
COIL SPRINGS			
TDC270	1	40mm Lift Spring (Pair)	Petrol/Diesel/Bar
TDC974	1	40mm Lift Spring (Pair)	Petrol/Diesel/Bar/Winch
COMPLETE STRUT ASSEMBLY			
HOL-001	2	BM404200/TDC270	Petrol/Diesel/Bar
HOL-002	2	BM404200/TDC974	Petrol/Diesel/Bar/Winch
HOL-003	2	FC404200/TDC270	Petrol/Diesel/Bar
HOL-004	2	FC404200/TDC974	Petrol/Diesel/Bar/Winch
ADDITIONAL COMPONENTS			
TOY-1081	1	Strut Top	Replacement Strut Top

REAR SUSPENSION

PART NO.	Qty	DESCRIPTION	NOTES
SHOCK ABSORBERS			
BD1125T	2	Nitrogen Gas Shock	Suit Up To 40mm Lift
FC41125	2	Foam Cell Shock	Suit Up To 40mm Lift
BM401125	2	40mm Adjustable Shock	Suit Up To 40mm Lift
COIL SPRINGS			
TDC271	1	0-300KG Load (Pair)	40mm Lift
TDC271H	1	CONSTANT 300KG Load (Pair)	40mm Lift
AIR ASSIST BAGS			
TDAA-005	1	Coil Insert Bag Kit	Suit 40mm Lift
TDAA-013	1	Coil Insert Bag Kit	Suit Standard Height Only

REPLACEMENT BUSHINGS

PART NO.	Qty	DESCRIPTION	NOTES
QUANTITY PER SHOCK			
ADJ300/40A	1	Suit Bottom Front Eye	Eyering Bonded Bushing
TW040-14	1	Suit Rear Bottom Eye	Eyering Bush
TW959	2	Suit Rear Top Pin	Pin Style Bushing

Fitting sheet (located page 243) must be completed when suspension fitted. Failure to comply may affect warranty.



FRONT SUSPENSION

ESTIMATED LIFT: 45mm

PART NO.	Qty	DESCRIPTION	NOTES
SHOCK ABSORBERS			
FC42059B	2	Foam Cell Shock	Suit Up To 45mm Lift
TORSION BARS			
4WTB-1725	1	Replacement Torsion Bars (Pair)	27.5mm/1275mm
Adjust Torsion bars after fitting shocks - Ensure a minimum of 60mm droop is maintained			

REAR SUSPENSION

PART NO.	Qty	DESCRIPTION	NOTES
SHOCK ABSORBERS			
FC41120B	2	Foam Cell Shock	Suit OE Height
BM401120	2	40mm Adjustable Shock	
FC41121B	2	Foam Cell Shock	Suit 45mm Lift
BM401121	2	40mm Adjustable Shock	
COIL SPRINGS			
TDC680	1	0-300KG Load (Pair)	45mm Lift
TDC632SL	1	CONSTANT 300KG Load (Pair)	45mm Lift

REPLACEMENT BUSHINGS

PART NO.	Qty	DESCRIPTION	NOTES
QUANTITY PER SHOCK			
402267	2	Suit Top Front Pin	Pin Style Bushing
412773	1	Suit Bottom Front Eye	Eyering Bushing
402267	2	Suit Top Rear Pin	Pin Style Bushing
ADJ00191	1	Suit Bottom Rear Eye	Eyering Bushing



FRONT SUSPENSION

ESTIMATED LIFT: 45mm

PART NO.	Qty	DESCRIPTION	NOTES
SHOCK ABSORBERS			
FC42019B	2	Foam Cell Shock	Suit Up To 45mm Lift
TORSION BARS			
4WTB-1559	1	Replacement Torsion Bars (Pair)	30mm/1145mm
Adjust Torsion bars after fitting shocks - Ensure a minimum of 60mm droop is maintained			

REAR SUSPENSION

PART NO.	Qty	DESCRIPTION	NOTES
SHOCK ABSORBERS			
BD1382T	2	Nitrogen Gas Shock	
FC41382	2	Foam Cell Shock	Suit OE Height
BM401382	2	40mm Adjustable Shock	
BD1388T	2	Nitrogen Gas Shock	
FC41388	2	Foam Cell Shock	Suit 45mm Lift
BM401388	2	40mm Adjustable Shock	
LEAF SPRINGS			
FS213	2	0-300KG Load	45mm Lift
FS213H	2	CONSTANT 300KG Load	45mm Lift
ADDITIONAL COMPONENTS			
TDUK-065	1	Urethane Shackle Bushing Kit	
TDUB-039	2	U-Bolt Kit	
TDGS-386	1	Greasable Shackle Kit	
TDGP-668	1	Greasable Pin Kit	
AIR ASSIST BAGS			
TDAA-103	1	Bellows Bag Kit	Suit 45mm Lift

REPLACEMENT BUSHINGS

PART NO.	Qty	DESCRIPTION	NOTES
QUANTITY PER SHOCK			
TW959	2	Suit Top Front Pin	Pin Style Bushing
412772	1	Suit Bottom Front Eye	Eyering Bushing
404702	1	Suit Top & Bottom Rear Eye	Eyering Bushing

Fitting sheet (located page 243) must be completed when suspension fitted. Failure to comply may affect warranty.



THIS PAGE IS INTENTIONALLY BLANK

All prices exclude freight. Include only permanent accessories & weights when selecting springs. Towing weight is not included.





FRONT SUSPENSION

ESTIMATED LIFT: 40mm

PART NO.	Qty	DESCRIPTION	NOTES
SHOCK ABSORBERS			
FC404200	2	Foam Cell Strut	
BM404200	2	40mm Adjustable Strut	9 Stage Adjustable
COIL SPRINGS			
TDC270	1	40mm Lift Spring (Pair)	Petrol/Diesel/Up To Alloy Bar
TDC974	1	40mm Lift Spring (Pair)	Petrol/Diesel/Bar
TDC974H	1	40mm Lift Spring (Pair)	Petrol/Diesel/Bar/Winch
COMPLETE STRUT ASSEMBLY			
HOL-001	2	BM404200/TDC270	Petrol/Diesel/Up To Alloy Bar
HOL-002	2	BM404200/TDC974	Petrol/Diesel/Bar
HOL-005	2	BM404200/TDC974H	Petrol/Diesel/Bar/Winch
HOL-003	2	FC404200/TDC270	Petrol/Diesel/Up To Alloy Bar
HOL-004	2	FC404200/TDC974	Petrol/Diesel/Bar
HOL-006	2	FC404200/TDC974H	Petrol/Diesel/Bar/Winch
ADDITIONAL COMPONENTS			
TOY-1081	1	Strut Top	Replacement Strut Top

REPLACEMENT BUSHINGS

PART NO.	Qty	DESCRIPTION	NOTES
QUANTITY PER SHOCK			
ADJ300/40A	1	Suit Bottom Front Eye	Eyering Bonded Bushing
404702	2	Suit Top & Bottom Rear Eyering	Eyering Bushing
TW038-16	2	Suit Top & Bottom Rear Eyering	Eyering Bushing - Super Soft Only

Fitting sheet (located page 243) must be completed when suspension fitted. Failure to comply may affect warranty.



ISUZU

D-MAX - TFS85, V-CROSS, MY12
05/2012-04/2016



REAR SUSPENSION

ESTIMATED LIFT: 40mm

PART NO.	Qty	DESCRIPTION	NOTES
SHOCK ABSORBERS			
BD1382T	2	Nitrogen Gas Shock	Suit Up To 40mm Lift
FC43032	2	Foam Cell Shock	Suit 40mm Lift ONLY - Super Soft*
FC41382	2	Foam Cell Shock	Suit Up To 40mm Lift
BM401382	2	40mm Adjustable Shock	Suit Up To 40mm Lift
LEAF SPRINGS			
FS214C	2	0-300KG Load	40mm Lift
FS214L	2	CONSTANT 300KG Load	40mm Lift
FS214LL	2	CONSTANT 500KG Load	40mm Lift
ADDITIONAL COMPONENTS			
TDUK-071	1	Urethane Shackle Bushing Kit	
TDUB-016	2	U-Bolt Kit	
TDGS-391	1	Greasable Shackle Kit	
TDGP-668	1	Greasable Pin Kit	
TDSK-021	1	Handbrake Relocation Kit	MUST be fitted to ALL kits
AIR ASSIST BAGS			
TDAA-104	1	Bellows Bag Kit	Suit 40mm Lift
TDAA-118	1	Bellows Bag Kit	Suit Standard Height Only

All prices exclude freight. Include only permanent accessories & weights when selecting springs. Towing weight is not included.



FRONT SUSPENSION

ESTIMATED LIFT: 40mm

PART NO.	Qty	DESCRIPTION	NOTES
SHOCK ABSORBERS			
FC404200	2	Foam Cell Strut	
BM404200	2	40mm Adjustable Strut	9 Stage Adjustable
COIL SPRINGS			
TDC270	1	40mm Lift Spring (Pair)	Petrol/Diesel/Up To Alloy Bar
TDC974	1	40mm Lift Spring (Pair)	Petrol/Diesel/Bar
TDC974H	1	40mm Lift Spring (Pair)	Petrol/Diesel/Bar/Winch
COMPLETE STRUT ASSEMBLY			
HOL-001	2	BM404200/TDC270	Petrol/Diesel/Up To Alloy Bar
HOL-002	2	BM404200/TDC974	Petrol/Diesel/Bar
HOL-005	2	BM404200/TDC974H	Petrol/Diesel/Bar/Winch
HOL-003	2	FC404200/TDC270	Petrol/Diesel/Up To Alloy Bar
HOL-004	2	FC404200/TDC974	Petrol/Diesel/Bar
HOL-006	2	FC404200/TDC974H	Petrol/Diesel/Bar/Winch
ADDITIONAL COMPONENTS			
TOY-1081	1	Strut Top	Replacement Strut Top

REPLACEMENT BUSHINGS

PART NO.	Qty	DESCRIPTION	NOTES
QUANTITY PER SHOCK			
ADJ300/40A	1	Suit Bottom Front Eye	Eyering Bonded Bushing
404702	2	Suit Top & Bottom Rear Eyering	Eyering Bushing
TW038-16	2	Suit Top & Bottom Rear Eyering	Eyering Bushing - Super Soft Only

Fitting sheet (located page 243) must be completed when suspension fitted. Failure to comply may affect warranty.



ISUZU

D-MAX - TFS85, V-CROSS, MY12 04/2016-08/2020



REAR SUSPENSION

ESTIMATED LIFT: 40mm

PART NO.	Qty	DESCRIPTION	NOTES
SHOCK ABSORBERS			
BD1382T	2	Nitrogen Gas Shock	Suit Up To 40mm Lift
FC43032	2	Foam Cell Shock	Suit 40mm Lift ONLY - Super Soft*
FC41382	2	Foam Cell Shock	Suit Up To 40mm Lift
BM401382	2	40mm Adjustable Shock	Suit Up To 40mm Lift
LEAF SPRINGS			
FS214C	2	0-300KG Load	40mm Lift
FS214L	2	CONSTANT 300KG Load	40mm Lift
FS214LL	2	CONSTANT 500KG Load	40mm Lift
ADDITIONAL COMPONENTS			
TDUK-071	1	Urethane Shackle Bushing Kit	
TDUB-016	2	U-Bolt Kit	
TDGS-391	1	Greasable Shackle Kit	
TDGP-668	1	Greasable Pin Kit	
AIR ASSIST BAGS			
TDAA-104	1	Bellows Bag Kit	Suit 40mm Lift
TDAA-118	1	Bellows Bag Kit	Suit Standard Height Only

All prices exclude freight. Include only permanent accessories & weights when selecting springs. Towing weight is not included.





FRONT SUSPENSION

ESTIMATED LIFT: 40mm

PART NO.	Qty	DESCRIPTION	NOTES
SHOCK ABSORBERS			
FC404929	2	Foam Cell Strut	
BM404929	2	40mm Adjustable Strut	9 Stage Adjustable
COIL SPRINGS			
TDC974	1	40mm Lift Spring (Pair)	Diesel
TDC974H	1	40mm Lift Spring (Pair)	Diesel/Bar & Winch
COMPLETE STRUT ASSEMBLY			
ISU-001	2	BM404929/TDC974	Diesel Up To Bar
ISU-002	2	BM404929/TDC974H	Diesel/Bar & Winch
ISU-003	2	FC404929/TDC974	Diesel Up To Bar
ISU-004	2	FC404929/TDC974H	Diesel/Bar & Winch
ADDITIONAL COMPONENTS			
ISU-4929	1	Strut Top	Replacement Strut Top

REAR SUSPENSION

PART NO.	Qty	DESCRIPTION	NOTES
SHOCK ABSORBERS			
FC43035	2	Foam Cell Shock	Suit Up To 40mm Lift
BM403035	2	40mm Adjustable Shock	Suit Up To 40mm Lift
LEAF SPRINGS			
FS215C	2	0-300KG Load	40mm Lift
FS214L	2	CONSTANT 300KG Load	40mm Lift
FS214LL	2	CONSTANT 500KG Load	40mm Lift
ADDITIONAL COMPONENTS			
TDUK-085	1	Urethane Shackle Bushing Kit	
TDUB-016	2	U-Bolt Kit	
TDGS-902	1	Greasable Shackle Kit	
TDGP-668	1	Greasable Pin Kit	
TDSK-021	1	Handbrake Relocation Kit	Fit with FS214L & FS214LL
AIR ASSIST BAGS			
TDAA-131	1	Bellows Bag Kit	Suit 40mm Lift
TDAA-130	1	Bellows Bag Kit	Suit Standard Height Only

REPLACEMENT BUSHINGS

PART NO.	Qty	DESCRIPTION	NOTES
QUANTITY PER SHOCK			
ADJ300/40A	1	Suit Bottom Front Eye	Eyering Bonded Bushing
TW038-16	2	Suit Top & Bottom Rear Eyering	Eyering Bushing

Fitting sheet (located page 243) must be completed when suspension fitted. Failure to comply may affect warranty.



FRONT SUSPENSION

ESTIMATED LIFT: 40mm

PART NO.	Qty	DESCRIPTION	NOTES
SHOCK ABSORBERS			
FC404200	2	Foam Cell Strut	
BM404200	2	40mm Adjustable Strut	9 Stage Adjustable
COIL SPRINGS			
TDC270	1	40mm Lift Spring (Pair)	Petrol/Diesel/ Up To Alloy Bar
TDC974	1	40mm Lift Spring (Pair)	Petrol/Diesel/ Bar
TDC974H	1	40mm Lift Spring (Pair)	Pertol/Diesel/Bar/Winch
COMPLETE STRUT ASSEMBLY			
HOL-001	2	BM404200/TDC270	Petrol/Diesel/Up To Alloy Bar
HOL-002	2	BM404200/TDC974	Petrol/Diesel/Bar
HOL-005	2	BM404200/TDC974H	Petrol/Diesel/Bar/Winch
HOL-003	2	FC404200/TDC270	Petrol/Diesel/Up To Alloy Bar
HOL-004	2	FC404200/TDC974	Petrol/Diesel/Bar
HOL-006	2	FC404200/TDC974H	Petrol/Diesel/Bar/Winch
ADDITIONAL COMPONENTS			
TOY-1081	1	Strut Top	Replacement Strut Top

REAR SUSPENSION

PART NO.	Qty	DESCRIPTION	NOTES
SHOCK ABSORBERS			
BD1125T	2	Nitrogen Gas Shock	Suit Up To 40mm Lift
FC41125	2	Foam Cell Shock	Suit Up To 40mm Lift
BM401125	2	40mm Adjustable Shock	Suit Up To 40mm Lift
COIL SPRINGS			
TDC272	1	0-300KG Load (Pair)	40mm Lift
TDC272H	1	CONSTANT 300KG Load (Pair)	40mm Lift
AIR ASSIST BAGS			
TDAA-005	1	Coil Insert Bag Kit	Suit 40mm Lift
TDAA-013	1	Coil Insert Bag Kit	Suit Standard Height Only

REPLACEMENT BUSHINGS

PART NO.	Qty	DESCRIPTION	NOTES
QUANTITY PER SHOCK			
ADJ300/40A	1	Suit Bottom Front Eye	Eyering Bonded Bushing
TW959	2	Suit Top Rear Pin	Pin Style Bushing
TW040-14	1	Suit Bottom Rear Eye	Eyering Bushing



FRONT SUSPENSION

ESTIMATED LIFT: 35mm

PART NO.	Qty	DESCRIPTION	NOTES
SHOCK ABSORBERS			
FC41063	2	Foam Cell Shock	Suit OE Height
BM401063	2	40mm Adjustable Shock	
FC41068	2	Foam Cell Shock	Suit 35mm Lift
BM401068	2	40mm Adjustable Shock	
COIL SPRINGS			
TDC333	1	35mm Lift (Pair)	Petrol/Diesel/Bar
TDC352	1	35mm Lift (Pair)	Petrol/Diesel/Bar/Winch
STEERING DAMPERS			
SS5922-P/S	1	Return To Centre Damper	Power Steering
SV5922	1	9 Stage Adjustable Damper	

REAR SUSPENSION

PART NO.	Qty	DESCRIPTION	NOTES
SHOCK ABSORBERS			
FC41241	2	Foam Cell Shock	Suit OE Height
BM401241	2	40mm Adjustable Shock	
FC41249	2	Foam Cell Shock	Suit 35mm Lift
BM401249	2	40mm Adjustable Shock	
LEAF SPRINGS			
1 Left Hand Side and 1 Right Hand Side leaf spring pack should be ordered			
FS025H-LH	1	0-300KG Load	35mm Lift Left Hand Side
FS025H-RH	1	0-300KG Load	35mm Lift Right Hand Side
ADDITIONAL COMPONENTS			
TDUK-027	1	Urethane Bushing Kit	
TDUB-027	2	U-Bolt Kit	
TDSP-002	1	Transmission Spacer	

REPLACEMENT BUSHINGS

PART NO.	Qty	DESCRIPTION	NOTES
QUANTITY PER SHOCK			
TW959	2	Suit Top Front Pin	Pin Style Bushing
404702	1	Suit Bottom Rear Eye	Eyering Bushing
Bar Pin Style Bushings Not User Servicable - Contact 4 Way Suspension for Replacement Service			

Fitting sheet (located page 243) must be completed when suspension fitted. Failure to comply may affect warranty.



JEEP

GRAND CHEROKEE

WG, WJ - 06-1999-2005 ZG - 04-1996-1999



FRONT SUSPENSION

ESTIMATED LIFT: 30mm

PART NO.	Qty	DESCRIPTION	NOTES
SHOCK ABSORBERS			
FC41068	2	Foam Cell Shock	
BM401068	2	40mm Adjustable Shock	9 Stage Adjustable
COIL SPRINGS			
TDC358	1	30mm Lift Spring (Pair)	30mm Lift - ZG 04/1996-1999 Only
TDC360	1	30mm Lift Spring (Pair)	30mm Lift - WG, WJ 6/99-05 Only
STEERING DAMPERS			
SS5922-P/S	1	Return To Centre Damper	ZG ONLY
SV5922	1	9 Stage Adjustable Damper	
SS5924-P/S	1	Return To Centre Damper	WG, WJ ONLY
SV5924	1	9 Stage Adjustable Damper	

REAR SUSPENSION

PART NO.	Qty	DESCRIPTION	NOTES
SHOCK ABSORBERS			
FC41444	2	Foam Cell Shock	ZG ONLY
BM401444	2	40mm Adjustable Shock	
FC41190	2	Foam Cell Shock	WG, WJ ONLY
BM401190	2	40mm Adjustable Shock	
COIL SPRINGS			
TDC359	1	0-300KG Load (Pair)	30mm Lift - ZG 04/1996-1999 Only
TDC361	1	0-300KG Load (Pair)	30mm Lift - WG, WJ 6/99-05 Only

REPLACEMENT BUSHINGS

PART NO.	Qty	DESCRIPTION	NOTES
QUANTITY PER SHOCK			
TW959	2	Suit Top Front Pin	Pin Style Bushing
404702	1	Suit Bottom Rear Eye	Eyering Bushing
Bar Pin Style Bushings Not User Servicable - Contact 4 Way Suspension for Replacement Service			

All prices exclude freight. Include only permanent accessories & weights when selecting springs. Towing weight is not included.





FRONT SUSPENSION

ESTIMATED LIFT: 40mm

PART NO.	Qty	DESCRIPTION	NOTES
SHOCK ABSORBERS			
FC404930	2	Foam Cell Shock	
COIL SPRINGS			
TDC1038	1	40mm Lift Spring (Pair)	40mm Lift - 3.6 V6 Petrol
TDC1040	1	40mm Lift Spring (Pair)	40mm Lift - 3.2 Diesel
TDC1042	1	40mm Lift Spring (Pair)	40mm Lift - 5.7 V8 Petrol

REAR SUSPENSION

PART NO.	Qty	DESCRIPTION	NOTES
SHOCK ABSORBERS			
FC43038	2	Foam Cell Shock	
COIL SPRINGS			
TDC1039	1	0-300KG Load (Pair)	40mm Lift - V6/V8 Petrol
TDC1041	1	0-300KG Load (Pair)	40mm Lift - Diesel

PLEASE NOTE:

This Kit is NOT compatible with the Nivomat (self leveling suspension) models. Standard shocks have an OD of 51mm, where the Nivomat shocks have an OD of 63mm.

Also note that the rear of a vehicle with Nivomats may sag whilst the vehicle is parked because the Nivomat shocks are mechanical and the vehicle needs to be moving in order for the pump to build pressure and level the vehicle. Even though other shocks may fit, it is not recommended that the Nivomats are replaced with traditional shock absorbers.



JEEP
WRANGLER - TJ
10/1996-2007



FRONT SUSPENSION

ESTIMATED LIFT: 45mm

PART NO.	Qty	DESCRIPTION	NOTES
SHOCK ABSORBERS			
BD1063T	2	Nitrogen Gas Shock	Suit OE Height
BM401063	2	40mm Adjustable Shock	
BD1068T	2	Nitrogen Gas Shock	Suit 45mm Lift
BM401068	2	40mm Adjustable Shock	
COIL SPRINGS			
TDC354	1	40mm Lift Spring (Pair)	Suit Up To Bar (45mm Lift)
STEERING DAMPERS			
SS5922-P/S	1	Return To Centre Damper	Power Steering
SV5922	1	9 Stage Adjustable Damper	
TRANSMISSION SPACER			
TDSP-001	1	Transmission Spacer	Manual/Auto - 10/96-03 ONLY
TDSP-005	1	Transmission Spacer	Auto - 03-07 ONLY
TDSP-006	1	Transmission Spacer	Manual - 03-07 ONLY

REAR SUSPENSION

PART NO.	Qty	DESCRIPTION	NOTES
SHOCK ABSORBERS			
BD1443T	2	Nitrogen Gas Shock	Suit OE Height
BM401443	2	40mm Adjustable Shock	
BD1461T	2	Nitrogen Gas Shock	Suit 45mm Lift
BM401461	2	40mm Adjustable Shock	
COIL SPRINGS			
TDC355	1	0-300KG Load (Pair)	45mm Lift

REPLACEMENT BUSHINGS

PART NO.	Qty	DESCRIPTION	NOTES
QUANTITY PER SHOCK			
TW959	2	Suit Top Front Pin	Pin Style Bushing
Bar Pin Style Bushings Not User Servicable - Contact 4 Way Suspension for Replacement Service			

All prices exclude freight. Include only permanent accessories & weights when selecting springs. Towing weight is not included.





FRONT SUSPENSION

ESTIMATED LIFT: 40mm

PART NO.	Qty	DESCRIPTION	NOTES
SHOCK ABSORBERS			
BM401069	2	40mm Adjustable Shock	Suit Up To 40mm Lift
COIL SPRINGS			
TDC331	1	40mm Lift Spring (Pair)	Petrol SWB - Up To Bar
TDC332	1	40mm Lift Spring (Pair)	Petrol SWB - Bar/Winch
TDC337	1	40mm Lift Spring (Pair)	Petrol LWB - Up To Bar
TDC338	1	40mm Lift Spring (Pair)	Petrol LWB - Bar/Winch
TDC332	1	40mm Lift Spring (Pair)	Diesel SWB - Up To Bar
TDC338	1	40mm Lift Spring (Pair)	Diesel SWB - Bar/Winch
TDC338	1	40mm Lift Spring (Pair)	Diesel LWB - Up To Bar
TDC342	1	40mm Lift Spring (Pair)	Diesel LWB - Bar/Winch
STEERING DAMPERS			
SV5926	1	9 Stage Adjustable Damper	
PANHARD RODS			
TDPR-017	1	Adjustable Panhard Rod	
TDUK-035	1	Replacement Panhard Rod Bush	

REAR SUSPENSION

PART NO.	Qty	DESCRIPTION	NOTES
SHOCK ABSORBERS			
BM401463	2	40mm Adjustable Shock	Suit 40mm Lift
COIL SPRINGS			
TDC340	1	0-300KG Load (Pair)	40mm Lift (SWB ONLY)
TDC339	1	CONSTANT 300KG Load (SWB) (Pair)	40mm Lift (0-300KG LWB)
TDC341	1	CONSTANT 300KG Load (LWB) (Pair)	40mm Lift

REPLACEMENT BUSHINGS

PART NO.	Qty	DESCRIPTION	NOTES
QUANTITY PER SHOCK			
TW959	2	Suit Top Front Pin	Pin Style Bushing
4W-SPF420-04	1	Suit Bottom Front Eying	Eying Bushing
Bar Pin Style Bushings Not User Servicable - Contact 4 Way Suspension for Replacement Service			

Fitting sheet (located page 243) must be completed when suspension fitted. Failure to comply may affect warranty.



JEEP
WRANGLER - TJ (EX RUBICON)
08/2018 ON



FRONT SUSPENSION

ESTIMATED LIFT: 50mm

PART NO.	Qty	DESCRIPTION	NOTES
SHOCK ABSORBERS			
FC43028	2	Foam Cell Shock	Suit Up To 50mm Lift
BM403028	2	40mm Adjustable Shock	Suit Up To 50mm Lift
COIL SPRINGS			
TDC1018	1	40mm Lift Spring (Pair)	Diesel/Bar (LWB)
TDC1019	1	40mm Lift Spring (Pair)	Diesel/Bar/Winch (LWB)
STEERING DAMPERS			
SV5929	1	9 Stage Adjustable Damper	
PANHARD RODS			
TDPR-022	1	Adjustable Panhard Rod	
TDUK-035	1	Replacement Panhard Bush Kit	

REAR SUSPENSION

PART NO.	Qty	DESCRIPTION	NOTES
SHOCK ABSORBERS			
FC43029	2	Foam Cell Shock	Suit Up To 50mm Lift
BM403029	2	40mm Adjustable Shock	Suit Up To 50mm Lift
COIL SPRINGS			
TDC1020	1	0-150KG Load (Pair)	Suit 50mm Lift (LWB)
TDC1021	1	CONSTANT 150-300KG Load (Pair)	Suit 50mm Lift (LWB)

All prices exclude freight. Include only permanent accessories & weights when selecting springs. Towing weight is not included.



JEEP
GLADIATOR - JT
2019 ON



COMING SOON

Fitting sheet (located page 243) must be completed when suspension fitted. Failure to comply may affect warranty.



LANDROVER

**80,88 SWB, 109 LWB - SERIES I, II, IIA & III
1953-1983**



FRONT SUSPENSION

NO SPRINGS AVAILABLE

PART NO.	Qty	DESCRIPTION	NOTES
SHOCK ABSORBERS			
BD2000T	2	Nitrogen Gas Shock	Suit Up To 50mm Lift
FC42000	2	Foam Cell Shock	Suit Up To 50mm Lift
STEERING DAMPERS			
EXT5000	1	Heavy Duty Steering Damper	Suit Series I, II, IIA & III
SS5000-M/S	1	Return To Centre Damper	Suit Series I ONLY
SV5000	1	9 Stage Adjustable Damper	Suit Series II, IIA, III ONLY

REAR SUSPENSION

PART NO.	Qty	DESCRIPTION	NOTES
SHOCK ABSORBERS			
BD3005T	2	Nitrogen Gas Shock	Suit Series I, II, IIA, III SWB
FC43005	2	Foam Cell Shock	
BD1399T	2	Nitrogen Gas Shock	Suit Series II, III LWB
FC41399	2	Foam Cell Shock	

REPLACEMENT BUSHINGS

PART NO.	Qty	DESCRIPTION	NOTES
QUANTITY PER SHOCK			
4W-SPF390	2	Suit Top & Bottom Front Eye	Eyering Bushing
4W-SPF390	2	Suit Top & Bottom Rear Eye	Eyering Bushing For #3005 Shocks
4W-SPF390	1	Suit Top Rear Mount	Eyering Bushing for #1399 Shocks
TW959	2	Suit Bottom Rear Pin Mount	Pin Bushing for #1399 Shocks
Bar Pin Style Bushings Not User Servicable - Contact 4 Way Suspension for Replacement Service			

All prices exclude freight. Include only permanent accessories & weights when selecting springs. Towing weight is not included.





FRONT SUSPENSION

ESTIMATED LIFT: 30mm

PART NO.	Qty	DESCRIPTION	NOTES
SHOCK ABSORBERS			
FC41049	2	Foam Cell Shock	Suit Up To 30mm Lift
BM401049	2	40mm Adjustable Shock	Suit Up To 30mm Lift
BMX1049/2	2	45mm Adjustable Shock	Suit Up To 30mm Lift
TDR1049B	2	'Raph' Shock	Suit Up To 30mm Lift
COIL SPRINGS			
TDC511	1	30mm Lift Spring (Pair)	Petrol/Bar
TDC513	1	30mm Lift Spring (Pair)	Diesel/Bar
TDC508H	1	30mm Lift Spring (Pair)	Petrol/Diesel/Bar/Winch
STEERING DAMPERS			
EXT5009	1	Heavy Duty Steering Damper	
SS5009-P/S	1	Return To Centre Steering Damper	
SV5009	1	9 Stage Adjustable Damper	
PANHARD RODS			
TDPR-002	1	Panhard Rod (14mm Sleeve)	Up To Chassis #2A626645
TDPR-018	1	Panhard Rod (16mm Sleeve)	Up To Chassis #2A626646

REAR SUSPENSION

PART NO.	Qty	DESCRIPTION	NOTES
SHOCK ABSORBERS			
FC41397	2	Foam Cell Shock	Suit Up To 30mm Lift
BM401397	2	40mm Adjustable Shock	Fit this part number if the lower rubber bushes are conical in shape and fit into a metal housing.
BMX1397/2	2	45mm Adjustable Shock	
TDR1397	2	'Ralph' Shock	
FC41398	2	Foam Cell Shock	Suit Up To 30mm Lift
BM401398	2	40mm Adjustable Shock	Fit this part number if the lower rubber bushes are flat and approx. 45mm in diameter.
BMX1398/2	2	45mm Adjustable Shock	
TDR1398	2	'Ralph' Shock	
COIL SPRINGS			
TDC512	1	0-300KG Load (Pair)	30mm Lift
TDC512HH	1	CONSTANT 300KG Load (Pair)	30mm Lift

Fitting sheet (located page 243) must be completed when suspension fitted. Failure to comply may affect warranty.



FRONT SUSPENSION

ESTIMATED LIFT: 30mm

PART NO.	Qty	DESCRIPTION	NOTES
SHOCK ABSORBERS			
FC41049	2	Foam Cell Shock	Suit Up To 30mm Lift
BM401049	2	40mm Adjustable Shock	Suit Up To 30mm Lift
BMX1049/2	2	45mm Adjustable Shock	Suit Up To 30mm Lift
TDR1049B	2	'Ralph' Shock	Suit Up To 30mm Lift
COIL SPRINGS			
TDC505	1	30mm Lift Spring (Pair)	Petrol/Bar
TDC535	1	30mm Lift Spring (Pair)	Petrol/Bar/Winch & Diesel/Bar
TDC504	1	30mm Lift Spring (Pair)	Diesel/Bar/Winch
STEERING DAMPERS			
EXT5009	1	Heavy Duty Steering Damper	
SS5009-P/S	1	Return To Centre Steering Damper	
SV5009	1	9 Stage Adjustable Damper	
PANHARD RODS			
TDPR-002	1	Panhard Rod (14mm Sleeve)	Up To Chassis #2A626645
TDPR-018	1	Panhard Rod (16mm Sleeve)	Up To Chassis #2A626646
TDUK-028	1	Replacement Bushes - TDPR-002	2 Bushes In Kit
TDUK-029	1	Replacement Bushes - TDPR-018	2 Bushes In Kit

REAR SUSPENSION

PART NO.	Qty	DESCRIPTION	NOTES
SHOCK ABSORBERS			
FC41397	2	Foam Cell Shock	Suit Up To 30mm Lift
BM401397	2	40mm Adjustable Shock	Fit this part number if the lower rubber bushes are conical in shape and fit into a metal housing.
BMX1397/2	2	45mm Adjustable Shock	
TDR1397	2	'Ralph' Shock	
FC41398	2	Foam Cell Shock	Suit Up To 30mm Lift
BM401398	2	40mm Adjustable Shock	Fit this part number if the lower rubber bushes are flat and approx. 45mm in diameter.
BMX1398/2	2	45mm Adjustable Shock	
TDR1398	2	'Ralph' Shock	
COIL SPRINGS			
TDC518	1	0-300KG Load (Pair)	30mm Lift
TDC518H	1	CONSTANT 300KG Load (Pair)	30mm Lift
TDC504	1	CONSTANT 500KG Load (Pair)	30mm Lift



FRONT SUSPENSION

ESTIMATED LIFT: 30mm

PART NO.	Qty	DESCRIPTION	NOTES
SHOCK ABSORBERS			
FC41049	2	Foam Cell Shock	Suit Up To 30mm Lift
BM401049	2	40mm Adjustable Shock	Suit Up To 30mm Lift
BMX1049/2	2	45mm Adjustable Shock	Suit Up To 30mm Lift
TDR1049B	2	'Ralph' Shock	Suit Up To 30mm Lift
COIL SPRINGS			
TDC520	1	30mm Lift Spring (Pair)	110, 130 Series Bar
TDC514	1	30mm Lift Spring (Pair)	110, 130 Series Bar/Winch
STEERING DAMPERS			
EXT5009	1	Heavy Duty Steering Damper	
SS5009-P/S	1	Return To Centre Steering Damper	
SV5009	1	9 Stage Adjustable Damper	
PANHARD RODS			
TDPR-002	1	Panhard Rod (14mm Sleeve)	Up To Chassis #2A626645
TDPR-018	1	Panhard Rod (16mm Sleeve)	Up To Chassis #2A626646
TDUK-028	1	Replacement Bushes - TDPR-002	2 Bushes In Kit
TDUK-029	1	Replacement Bushes - TDPR-018	2 Bushes In Kit

REAR SUSPENSION

PART NO.	Qty	DESCRIPTION	NOTES
SHOCK ABSORBERS			
FC41397	2	Foam Cell Shock	Suit Up To 30mm Lift
BM401397	2	40mm Adjustable Shock	Fit this part number if the lower rubber bushes are conical in shape and fit into a metal housing.
BMX1397/2	2	45mm Adjustable Shock	
TDR1397	2	'Ralph' Shock	
FC41398	2	Foam Cell Shock	Suit Up To 30mm Lift
BM401398	2	40mm Adjustable Shock	Fit this part number if the lower rubber bushes are flat and approx. 45mm in diameter.
BMX1398/2	2	45mm Adjustable Shock	
TDR1398	2	'Ralph' Shock	
COIL SPRINGS			
TDC536	1	0-300KG Load (Pair)	30mm Lift - Suit 110 Series
TDC523	1	0-500KG Load (Pair)	30mm Lift - Suit 130 Series LWB
TDC522H	1	CONSTANT 500KG Load (Pair)	30mm Lift - Suit 130 Series LWB

REPLACEMENT BUSHINGS

PART NO.	Qty	DESCRIPTION	NOTES
QUANTITY PER SHOCK			
TW957	4	Suit Top & Bottom Front	
415024	1	Suit Top Rear	1397 Shocks
TW967	2	Suit Bottom Rear	1397 Shocks
ADJ00191	1	Suit Bottom Rear	1398 Shocks

Fitting sheet (located page 243) must be completed when suspension fitted. Failure to comply may affect warranty.



FRONT SUSPENSION

ESTIMATED LIFT: 30mm

PART NO.	Qty	DESCRIPTION	NOTES
SHOCK ABSORBERS			
FC41049	2	Foam Cell Shock	Suit Up To 30mm Lift
BM401049	2	40mm Adjustable SHock	Suit Up To 30mm Lift
BMX1049/2	2	45mm Adjustable Shock	Suit Up To 30mm Lift
TDR1049B	2	'Ralph' Shock	Suit Up To 30mm Lift
COIL SPRINGS			
TDC505	1	30mm Lift Spring (Pair)	Suit Up To Bar
TDC504	1	30mm Lift Spring (Pair)	Suit Bar/Winch
STEERING DAMPERS			
EXT5000	1	Heavy Duty Steering Damper	
SS5000-P/S	1	Return To Centre Damper	Power Steering
SV5000	1	9 Stage Adjustable Damper	
PANHARD RODS			
TDPR-002	1	Panhard Rod (14mm Sleeve)	Up To Chassis #2A626645
TDUK-028	1	Replacement Panhard Rod Bush	

REAR SUSPENSION

PART NO.	Qty	DESCRIPTION	NOTES
SHOCK ABSORBERS			
FC41397	2	Foam Cell Shock	Suit Up To 30mm Lift
BM401397	2	40mm Adjustable Shock	Fit this part number if the lower rubber bushes are conical in shape & fit into a metal housing.
BMX1397/2	2	45mm Adjustable Shock	
TDR1397	2	'Ralph' Shock	
FC41398	2	Foam Cell Shock	Suit Up To 30mm Lift
BM401398	2	40mm Adjustable Shock	Fit the part number if the lower rubber bushes are flat & approx. 45mm in diameter.
BMX1398/2	2	45mm Adjustable Shock	
TDR1398	2	'Ralph' Shock	
COIL SPRINGS			
TDC518	1	0-300KG Load (Pair)	30mm Lift
TDC518H	1	CONSTANT 300KG Load (Pair)	30mm Lift

REPLACEMENT BUSHINGS

PART NO.	Qty	DESCRIPTION	NOTES
QUANTITY PER SHOCK			
TW967	2	Suit Bottom Rear Pin	Pin Style Bushing #1397 Shocks
415024	1	Suit Top Rear Eye	Eyering Bushing #1397 Shocks
ADJ00191	1	Suit Top Rear Eye	Eyering Bushing #1398 Shocks
TW957	2	Suit Bottom Rear Pin	Eyering Bushing #1398 Shocks
TW957	4	Suit Top & Bottom Front	Pin Style Bushing #1049 Shocks



FRONT SUSPENSION

ESTIMATED LIFT: 35mm

PART NO.	Qty	DESCRIPTION	NOTES
SHOCK ABSORBERS			
FC41043	2	Foam Cell Shock	Suit Up To 35mm Lift (Series II ONLY)
BM401043	2	40mm Adjustable Shock	Suit Up To 35mm Lift (Series II ONLY)
COIL SPRINGS			
TDC530	1	35mm Lift Spring (Pair)	Suit Series II Up To Bar
TDC530H	1	35mm Lift Spring (Pair)	Suit Series II Bar/Winch
TDC545	1	40mm Lift Spring (Pair)	Suit Series III Up To Bar
TDC545H	1	40mm Lift Spring (Pair)	Suit Series III Bar/Winch
STEERING DAMPERS			
EXT5003	1	Heavy Duty Steering Damper	Series II ONLY
SS5003-P/S	1	Return To Centre Damper	Series II Only Power Steering
SV5003	1	9 Stage Adjustable Damper	Series II Only

REAR SUSPENSION

PART NO.	Qty	DESCRIPTION	NOTES
SHOCK ABSORBERS			
FC41396	2	Foam Cell Shock	Suit Up To 35mm Lift (Series II ONLY)
BM401396	2	40mm Adjustable Shock	Suit Up To 35mm Lift (Series II ONLY)
COIL SPRINGS			
TDC508	1	0-300KG Load (Pair)	35mm Lift (Series II ONLY)
TDC508H	1	CONSTANT 300KG Load (Pair)	35mm Lift (Series II ONLY)
TDC546	1	0-300KG Load (Pair)	40mm Lift (Series III ONLY)
TDC546H	1	CONSTANT 300KG Load (Pair)	40mm Lift (Series III ONLY)

Fitting sheet (located page 243) must be completed when suspension fitted. Failure to comply may affect warranty.



FRONT SUSPENSION

ESTIMATED LIFT: 35mm

PART NO.	Qty	DESCRIPTION	NOTES
SHOCK ABSORBERS			
FC41049	2	Foam Cell Shock	
BM401049	2	40mm Adjustable Shock	Suit Up To 35mm Lift Without Air Suspension
BMX1049/2	2	45mm Adjustable Shock	
TDR1049B	2	'Ralph' Shock	
COIL SPRINGS - NON AIR SUSPENSION MODELS			
TDC501	1	OE Height Spring (Pair)	Petrol/Bar
TDC505	1	35mm Lift Spring (Pair)	Diesel/Bar
TDC504	1	35mm Lift Spring (Pair)	Petrol/Diesel/Bar/Winch
STEERING DAMPERS			
EXT5000	1	Heavy Duty Steering Damper	
SS5000-P/S	1	Return To Centre Damper	Power Steering
SV5000	1	9 Stage Adjustable Damper	
PANHARD RODS			
TDPR-002	1	Panhard Rod (14mm Sleeve)	
TDPR-018	1	Panhard Rod (16mm Sleeve)	

REAR SUSPENSION

PART NO.	Qty	DESCRIPTION	NOTES
SHOCK ABSORBERS			
FC41398	2	Foam Cell Shock	
BM401398	2	40mm Adjustable Shock	Suit Up To 35mm Lift Without Air Suspension
BMX1398/2	2	45mm Adjustable Shock	
TDR1398	2	'Ralph' Shock	
COIL SPRINGS			
TDC504	1	0-300KG Load (Pair)	35mm Lift
TDC508	1	CONSTANT 300KG Load (Pair)	35mm Lift
TDC508H	1	CONSTANT 500KG Load (Pair)	35mm Lift



FRONT SUSPENSION

ESTIMATED LIFT: 35mm

PART NO.	Qty	DESCRIPTION	NOTES
SHOCK ABSORBERS			
FC41008	2	Foam Cell Shock	
BM401008	2	40mm Adjustable Shock	Suit Up To 35mm Lift
BMX1008/2	2	45mm Adjustable Shock	Suit all models WITH AIR SUSPENSION
TDR1008	2	'Ralph' Shock	
STEERING DAMPERS			
EXT5000	1	Heavy Duty Steering Damper	
SS5000-P/S	1	Return To Centre Damper	Power Steering
SV5000	1	9 Stage Adjustable Damper	
PANHARD RODS			
T DPR-002	1	Panhard Rod (14mm Sleeve)	

REAR SUSPENSION

PART NO.	Qty	DESCRIPTION	NOTES
SHOCK ABSORBERS			
FC41397	2	Foam Cell Shock	
BM401397	2	40mm Adjustable Shock	Suit Up To 35mm Lift
BMX1397/2	2	45mm Adjustable Shock	Suit all models WITH AIR SUSPENSION
TDR1397	1	'Ralph' Shock	

REPLACEMENT BUSHINGS

PART NO.	Qty	DESCRIPTION	NOTES
QUANTITY PER SHOCK			
TW957	2	Suit Top & Bottom Front Pin	Pin Style Bushing #1008 Shocks
415024	1	Suit Top Rear Eye	Eyering Bushing #1397 Shocks
TW967	2	Suits Bottom Rear Pin	Pin Style Bushing #1397 Shocks

Fitting sheet (located page 243) must be completed when suspension fitted. Failure to comply may affect warranty.



LADA
NIVA
07/1983-1998



FRONT SUSPENSION

ESTIMATED LIFT: 25mm

PART NO.	Qty	DESCRIPTION	NOTES
SHOCK ABSORBERS			
BD2006T	2	Nitrogen Gas Shock	Suit Up To 25mm Lift
COIL SPRINGS			
TDC402	1	25mm Lift Spring (Pair)	All Applications

REAR SUSPENSION

PART NO.	Qty	DESCRIPTION	NOTES
SHOCK ABSORBERS			
BD3020T	2	Nitrogen Gas Shock	Suit Up To 25mm Lift
COIL SPRINGS			
TDC403	1	25mm Lift Spring (Pair)	All Applications

REPLACEMENT BUSHINGS

PART NO.	Qty	DESCRIPTION	NOTES
QUANTITY PER SHOCK			
TW959	2	Suit Top Front Pin	Pin Style Bushing
412773	1	Suit Bottom Front Eye	Eyering Bushing
404702	1	Suit Top Rear Eye	Eyering Bushing
4W-SPF420-02	1	Suit Bottom Rear Eye	Eye Style Bushing

All prices exclude freight. Include only permanent accessories & weights when selecting springs. Towing weight is not included.





FRONT SUSPENSION

ESTIMATED LIFT: 40mm

PART NO.	Qty	DESCRIPTION	NOTES
SHOCK ABSORBERS			
FC404926	2	Foam Cell Strut	
BM404926	2	40mm Adjustable Strut	9 Stage Adjustable
COIL SPRINGS			
TDC270	1	40mm Lift Spring (Pair)	Petrol/Diesel/Up To Alloy Bar
TDC974	1	40mm Lift Spring (Pair)	Petrol/Diesel/Bar
TDC974H	1	40mm Lift Spring (Pair)	Petrol/Diesel/Bar/Winch
COMPLETE STRUT ASSEMBLY			
LDV-001	2	BM404925/TDC270	Petrol/Diesel/Up To Alloy Bar
LDV-002	2	BM404926/TDC974	Petrol/Diesel/Bar
LDV-003	2	BM404926/TDC974H	Petrol/Diesel/Bar/Winch
LDV-004	2	FC404926/TDC270	Petrol/Diesel/Up To Alloy Bar
LDV-005	2	FC404926/TDC974	Petrol/Diesel/Bar
LDV-006	2	FC404926/TDC974H	Petrol/Diesel/Bar/Winch
ADDITIONAL COMPONENTS			
TOY-1081	2	Strut Top	Replacement Strut Top

REAR SUSPENSION

PART NO.	Qty	DESCRIPTION	NOTES
SHOCK ABSORBERS			
FC43032	2	Foam Cell Shock	Suit Up To 40mm Lift
BM403032	2	40mm Adjustable Shock	Suit Up To 40mm Lift
LEAF SPRINGS			
FS214C	2	0-300KG Load	40mm Lift
FS214L	2	CONSTANT 300KG Load	40mm Lift
FS214LL	2	CONSTANT 500KG Load	40mm Lift
ADDITIONAL COMPONENTS			
TDUK-071	1	Urethane Shackle Bushing Kit	
TDUB-016	2	U-Bolt Kit	
TDGS-391	1	Greasable Shackle Kit	MUST Be Fitted With ALL Kits
TDGP-668	1	Greasable Pin Kit	MUST Be Fitted With ALL Kits
TDSP-020	1	Centre Bearing Spacer Kit	MUST Be Fitted With ALL Kits
TDSP-019	1	Headlight Leveling Relocator	MUST Be Fitted With ALL Kits
ADDITIONAL COMPONENTS			
TDAA-125	1	Bellows Bag Kit	Suit Standard Height ONLY
TDAA-126	1	Bellows Bag Kit	Suit 40mm Lift

Fitting sheet (located page 243) must be completed when suspension fitted. Failure to comply may affect warranty.



MAZDA

**B2500, B2600, B4000 - PC, PD, PE, PG, PH
1986-2006**



FRONT SUSPENSION

ESTIMATED LIFT: 40mm

PART NO.	Qty	DESCRIPTION	NOTES
SHOCK ABSORBERS			
FC42051B	2	Foam Cell Shock	Suit Up To 40mm Lift
TDSK-020	1	Shock Mount Strengthening Kit	Tip Pin Mount Bracket
Please Note - Failure to fit TDSK-020 will cause top mount failure			
TORSION BARS			
4WTB-1546	1	Replacement Torsion Bars (Pair)	26mm/926mm
Adjust Torsion bars after fitting shocks - Ensure a minimum of 60mm droop is maintained			

REAR SUSPENSION

PART NO.	Qty	DESCRIPTION	NOTES
SHOCK ABSORBERS			
FC41232	2	Foam Cell Shock	Suit Up To 40mm Lift
BM401232	2	40mm Adjustable Shock	Suit Up To 40mm Lift
LEAF SPRINGS			
FS365	2	0-300KG Load	40mm Lift
FS367	2	CONSTANT 300KG Lift	40mm Lift
COMPONENTS			
TDUK-034	1	Urethane Shackle Bushing Kit	
TDUB-005	2	U-Bolt Kit	

REPLACEMENT BUSHINGS

PART NO.	Qty	DESCRIPTION	NOTES
QUANTITY PER SHOCK			
TW959 + TW961	1	Suit Top Front Pin	Pin Style Bushing
4W-SPF420-05	1	Suit Bottom Front Eye	Suit Body #42057 ONLY
4W-SPF420-02	1	Suit Bottom Front Eye	Suit Body #42051 ONLY
ADJ00191	1	Suit Top Rear Eying	Suit Foam Cell Shocks
4W-SPF420-02	1	Suit Bottom Rear Eying	
230100	1	Suit Top Rear Eying	
230002	1	Suit Bottom Rear Eying	Suit 40mm Adjustable Shocks

All prices exclude freight. Include only permanent accessories & weights when selecting springs. Towing weight is not included.





MAZDA

BT-50 - B2500, B3000
11/2006-10/2011



FRONT SUSPENSION

ESTIMATED LIFT: 45mm

PART NO.	Qty	DESCRIPTION	NOTES
SHOCK ABSORBERS			
FC42051B	2	Foam Cell Shock	Suit Up To 40mm Lift
TDSK-020	1	Shock Mount Strengthening Kit	Top Pin Mount Bracket
Please Note - Failure to fit TDSK-020 will cause top mount failure			
TORSION BARS			
4WTB-1440	1	Replacement Torsion Bars (Pair)	27mm/1028mm
Adjust Torsion bars after fitting shocks - Ensure a minimum of 60mm droop is maintained			

REPLACEMENT BUSHINGS

PART NO.	Qty	DESCRIPTION	NOTES
QUANTITY PER SHOCK			
TW959 + TW961	1 ea	Suit Top Front Pin	Pin Style Bushing
4W-SPF420-05	1	Suit Bottom Front Eye	Suit Body #42057 ONLY
4W-SPF420-02	1	Suit Bottom Front Eye	Suit Body #42051 ONLY
ADJ00191	1	Suit Top Rear Eying	Suit Foam Cell Shocks
4W-SPF420-02	1	Suit Bottom Rear Eying	
230100	1	Suit Top Rear Eying	Suit 40mm Adjustable Shocks
230002	1	Suit Bottom Rear Eying	

Fitting sheet (located page 243) must be completed when suspension fitted. Failure to comply may affect warranty.



MAZDA
BT-50 - B2500, B3000
11/2006-10/2011



REAR SUSPENSION

ESTIMATED LIFT: 45mm

PART NO.	Qty	DESCRIPTION	NOTES
SHOCK ABSORBERS			
FC41232	2	Foam Cell Shock	Suit Up To 45mm Lift
BM401232	2	40mm Adjustable Shock	Suit Up To 45mm Lift
LEAF SPRINGS			
1 Left Hand Side and 1 Right Hand Side leaf spring pack should be ordered			
FS368C-LH	1	0-300KG Load	45mm Lift Left Hand Side
FS368C-RH	1	0-300KG Load	45mm Lift Right Hand Side
FS368L-LH	1	CONSTANT 300KG Load	45mm Lift Left Hand Side
FS368L-RH	1	CONSTANT 300KG Load	45mm Lift Right Hand Side
ADDITIONAL COMPONENTS			
TDUK-069	1	Urethane Shackle Bushing Kit	
TDUB-040	2	U-Bolt Kit	Suit FS368C-LH & -RH ONLY
TDUB-039	2	U-Bolt Kit	Suit FS368L-LH & -RH ONLY
TDGS-386/1	1	Greasable Shackle Kit	
TDGP-668	1	Greasable Pin Kit	
AIR ASSIST BAGS			
TDAA-101	1	Bellows Bag Kit	Suit 45mm Lift
TDAA-117	1	Bellows Bag Kit	Suit Standard Height ONLY

All prices exclude freight. Include only permanent accessories & weights when selecting springs. Towing weight is not included.



FRONT SUSPENSION

ESTIMATED LIFT: 40mm

PART NO.	Qty	DESCRIPTION	NOTES
SHOCK ABSORBERS			
FC404500	2	Foam Cell Strut	
BM404500	2	40mm Adjustable Strut	9 Stage Adjustable
COIL SPRINGS			
TDC451	1	40mm Lift Spring (Pair)	Petrol/Diesel/Bar
TDC451HL	1	40mm Lift Spring (Pair)	Petrol/Diesel/Bar/Winch
COMPLETE STRUT ASSEMBLY			
1 Left Hand Side and 1 Right Hand Side strut assembly should be ordered			
MAZ-001-LH	1	BM404500/TDC451	Bar Left Hand Side
MAZ-001-RH	1	BM404500/TDC451	Bar Right Hand Side
MAZ-002-LH	1	BM404500/TDC451HL	Bar/Winch Left Hand Side
MAZ-002-RH	1	BM404500/TDC451HL	Bar/Winch Right Hand Side
MAZ-003-LH	1	FC404500/TDC451	Bar Left Hand Side
MAZ-003-RH	1	FC404500/TDC451	Bar Right Hand Side
MAZ-004-LH	1	FC404500/TDC451HL	Bar/Winch Left Hand Side
MAZ-004-RH	1	FC404500/TDC451HL	Bar/Winch Right Hand Side
ADDITIONAL COMPONENTS			
MAZ-4051	2	Strut Top	Replacement Strut Top
TDCA-003	1	Upper Control Arms (Pair)	Suit Up To 50mm Lift
TDSK-003	1	Bush Kit for TDCA-003	Replacement Bush Kit
TDSK-004	1	Ball Joint Kit for TDCA-003	Replacement Ball Joint

REPLACEMENT BUSHINGS

PART NO.	Qty	DESCRIPTION	NOTES
QUANTITY PER SHOCK			
ADJ00305	1	Suit Bottom Front Eye	Eyering Bonded Bushing
ADJ00191	1	Suit Top Rear Eyering	Suit Foam Cell Shocks
4W-SPF420-02	1	Suit Bottom Rear Eyering	
230100	1	Suit Top Rear Eyering	Suit 40mm Adjustable Shocks
230002	1	Suit Bottom Rear Eyering	

PLEASE NOTE:

Fitment of Tough Dog upper control arms to vehicles that have lifts fitted greater than 50mm may suffer from premature ball joint failure due to longer droop lengths. The use of strut spacers may also effect the performance and longevity of the UCA ball joint due to the limitations of the spherical bearing housing being breached or bound at full suspension droop. There will be no warranty either expressed or implied if the vehicle is used out of legal driving conditions that will include but is not limited to jumping of the vehicle.



MAZDA
BT-50 - UP, UR
11/2011-08/2020



REAR SUSPENSION

ESTIMATED LIFT: 40mm

PART NO.	Qty	DESCRIPTION	NOTES
SHOCK ABSORBERS			
FC41232	2	Foam Cell Shock	Suit Up To 40mm Lift
BM401232	2	40mm Adjustable Shock	Suit Up To 40mm Lift
LEAF SPRINGS			
FS369C	2	0-300KG Load	40mm Lift
FS369L	2	CONSTANT 300KG Load	40mm Lift
FS369LL	2	CONSTANT 500KG Load	40mm Lift
ADDITIONAL COMPONENTS			
TDUK-070	1	Urethane Shackle Bushing Kit	
TDUB-039	2	U-Bolt Kit	Suit FS369L & FS369LL Spring
TDUB-040	2	U-Bolt Kit	Suit FS369C Spring ONLY
TDGS-390	1	Greasable Shackle Kit	
TDGP-668	1	Greasable Pin Kit	
TDSP-007	1	Transmission Spacer Kit	Must Be Fitted To ALL Lift Kits
AIR ASSIST BAGS			
TDAA-102	1	Bellows Air Bag	Suit 40mm Lift
TDAA-116	1	Bellows Air Bag	Suit Standard Height ONLY

All prices exclude freight. Include only permanent accessories & weights when selecting springs. Towing weight is not included.



FRONT SUSPENSION

ESTIMATED LIFT: 40mm

PART NO.	Qty	DESCRIPTION	NOTES
SHOCK ABSORBERS			
FC404929	2	Foam Cell Strut	
BM404929	2	40mm Adjustable Strut	9 Stage Adjustable
COIL SPRINGS			
TDC974	1	40mm Lift Spring (Pair)	Diesel
TDC974H	1	40mm Lift Spring (Pair)	Diesel/Bar & Winch
COMPLETE STRUT ASSEMBLY			
ISU-001	2	BM404929/TDC974	Diesel
ISU-002	2	BM404929/TDC974H	Diesel/ Bar & Winch
ISU-003	2	FC404929/TDC974	Diesel
ISU-004	2	FC404929/TDC974H	Diesel/Bar & Winch
ADDITIONAL COMPONENTS			
ISU-4929	2	Strut Top	Replacement Strut Top

REPLACEMENT BUSHINGS

PART NO.	Qty	DESCRIPTION	NOTES
QUANTITY PER SHOCK			
ADJ300/40A	1	Suit Bottom Front Eye	Eyering Bonded Bushing
TW038-16	2	Suit Top & Bottom Rear Eyering	Eyering Bushing

Fitting sheet (located page 243) must be completed when suspension fitted. Failure to comply may affect warranty.



MAZDA
BT-50 - TF
08/2020 ON



REAR SUSPENSION

ESTIMATED LIFT: 40mm

PART NO.	Qty	DESCRIPTION	NOTES
SHOCK ABSORBERS			
FC43035	2	Foam Cell Shock	Suit Up To 40mm Lift
BM403035	2	40mm Adjustable Shock	Suit Up To 40mm Lift
LEAF SPRINGS			
FS215C	2	0-300KG Load	40mm Lift
FS214L	2	CONSTANT 300KG Load	40mm Lift
FS214LL	2	CONSTANT 500KG Load	40mm Lift
ADDITIONAL COMPONENTS			
TDUK-085	1	Urethane Shackle Bushing Kit	
TDUB-016	2	U-Bolt Kit	
TDGS-902	1	Greasable Shackle Kit	
TDGP-668	1	Greasable Pin Kit	
TDSK-021	1	Handbrake Relocation Kit	Fit with FS214L & FS214LL
AIR ASSIST BAGS			
TDAA-130	1	Bellows Air Bag	Suit 40mm Lift
TDAA-131	1	Bellows Air Bag	Suit Standard Height ONLY

All prices exclude freight. Include only permanent accessories & weights when selecting springs. Towing weight is not included.



FRONT SUSPENSION

ESTIMATED LIFT: 35mm

PART NO.	Qty	DESCRIPTION	NOTES
SHOCK ABSORBERS			
FC404925	2	Foam Cell Strut	
BM404925	2	40mm Adjustable Strut	9 Stage Adjustable
COIL SPRINGS			
TDC1008	1	35mm Lift Spring (Pair)	Diesel/No Accessories
TDC1009	1	35mm Lift Spring (Pair)	Diesel/Bar & Diesel/Bar/Winch
COMPLETE STRUT ASSEMBLY			
MEC-001	2	BM404925/TDC1008	Diesel/No Accessories
MEC-002	2	BM404925/TDC1009	Diesel/Bar & Diesel/Bar/Winch
MEC-003	2	FC404925/TDC1008	Diesel/No Accessories
MEC-004	2	FC404925/TDC1009	Diesel/Bar & Diesel/Bar/Winch
ADDITIONAL COMPONENTS			
NIS-3030	2	Strut Top	Replacement Strut Top

REAR SUSPENSION

PART NO.	Qty	DESCRIPTION	NOTES
SHOCK ABSORBERS			
FC41369	2	Foam Cell Shock	Suit Up To 35mm Lift
BM401369	2	40mm Adjustable Shock	Suit Up To 35mm Lift
COIL SPRINGS			
TDC774	1	0-300KG Load (Pair)	35mm Lift
TDC774H	1	CONSTANT 300KG Load (Pair)	35mm Lift
TDC774VHL	1	CONSTANT 500KG Load (Pair)	35mm Lift
ADDITIONAL COMPONENTS			
TDPR-300	1	Adjustable Panhard Rod	
AIR ASSIST BAGS			
TDAA-007	1	Coil Insert Bag Kit	Suit 35mm Lift
TDAA-016	1	Coil Insert Bag Kit	Suit OE Height ONLY

REPLACEMENT BUSHINGS

PART NO.	Qty	DESCRIPTION	NOTES
QUANTITY PER SHOCK			
ADJ300/40A	1	Suit Bottom Front Eying	Eying Bonded Bushing
404702	1	Suit Top Rear Eying	Eying Bushing
TW040-14	1	Suit Bottom Rear Eying	Eying Bushing

Fitting sheet (located page 243) must be completed when suspension fitted. Failure to comply may affect warranty.



FRONT SUSPENSION

ESTIMATED LIFT: 35mm

PART NO.	Qty	DESCRIPTION	NOTES
SHOCK ABSORBERS			
FC42057B	2	Foam Cell Shock	Suit Up To 35mm Lift
TORSION BARS			
4WTB-0203	1	Replacement Torsion Bars (Pair)	27.5mm/1307mm
Adjust Torsion bars after fitting shocks - Ensure a minimum of 60mm droop is maintained			

REAR SUSPENSION

PART NO.	Qty	DESCRIPTION	NOTES
SHOCK ABSORBERS			
BD1382T	2	Nitrogen Gas Shock	Suit Up To 35mm Lift
FC41382	2	Foam Cell Shock	Suit Up To 35mm Lift
BM401382	2	40mm Adjustable Shock	Suit Up To 35mm Lift
LEAF SPRINGS			
FS021	2	0-300KG Load	35mm Lift
COMPONENTS			
TDSK-023	1	Anti Inversion Bracket Kit	MUST be fitted with ALL Leaf Springs
TDUK-066/31	1	Urethane Shackle Bushing Kit	
TDUB-006	2	U-Bolt Kit	

REPLACEMENT BUSHINGS

PART NO.	Qty	DESCRIPTION	NOTES
QUANTITY PER SHOCK			
TW959	2	Suit Top Front Pin	Pin Style Bushing
412772	1	Suit Bottom Front Eying	Eying Bonded Bushing
404702	2	Suit Top & Bottom Rear Eying	Eying Bushing



MITSUBISHI

CHALLENGER - PA II (COIL REAR)

06/2000-2007



FRONT SUSPENSION

ESTIMATED LIFT: 35mm

PART NO.	Qty	DESCRIPTION	NOTES
SHOCK ABSORBERS			
FC42057B	2	Foam Cell Shock	Suit Up To 35mm Lift
TORSION BARS			
4WTB-0203	1	Replacement Torsion Bars (Pair)	27.5mm/1307mm
Adjust Torsion bars after fitting shocks - Ensure a minimum of 60mm droop is maintained			

REAR SUSPENSION

PART NO.	Qty	DESCRIPTION	NOTES
SHOCK ABSORBERS			
FC41439	2	Foam Cell Shock	Suit Up To 35mm Lift
BM401439	2	40mm Adjustable Shock	Suit Up To 35mm Lift
COIL SPRINGS			
TDC640	1	0-300KG Load (Pair)	35mm Lift
TDC632SL	1	CONSTANT 300KG Load (Pair)	35mm Lift

REPLACEMENT BUSHINGS

PART NO.	Qty	DESCRIPTION	NOTES
QUANTITY PER SHOCK			
TW959	2	Suit Top Front Pin	Pin Style Bushing
412772	1	Suit Bottom Front Eying	Eying Bonded Bushing
404702	1	Suit Top Rear Eying	Eying Bushing
TW038-16	1	Suit Bottom Rear Eying	

Fitting sheet (located page 243) must be completed when suspension fitted. Failure to comply may affect warranty.



FRONT SUSPENSION

ESTIMATED LIFT: 25mm

PART NO.	Qty	DESCRIPTION	NOTES
SHOCK ABSORBERS			
FC404800	2	Foam Cell Strut	
BM404800	2	40mm Adjustable Strut	9 Stage Adjustable
COIL SPRINGS			
TDC670	1	25mm Lift Spring (Pair)	Petrol/Diesel/Bar
TDC670H	1	25mm Lift Spring (Pair)	Petrol/Diesel/Bar/Winch
COMPLETE STRUT ASSEMBLY			
MIT-060/01	2	BM404800/TDC670	Petrol/Diesel/Bar
MIT-060/02	2	BM404800/TDC670H	Petrol/Diesel/Bar/Winch
MIT-060/03	2	FC404800/TDC670	Petrol/Diesel/Bar
MIT-060/04	2	FC404800/TDC670H	Petrol/Diesel/Bar/Winch
ADDITIONAL COMPONENTS			
MIT-4040	2	Strut Top	Replacement Strut Top

REAR SUSPENSION

PART NO.	Qty	DESCRIPTION	NOTES
SHOCK ABSORBERS			
FC41440B	2	Foam Cell Shock	Suit Up To 25mm Lift
BM401440	2	40mm Adjustable Shock	Suit Up To 25mm Lift
COIL SPRINGS			
TDC636L	1	0-300KG Load (Pair)	25mm Lift
TDC636HL	1	CONSTANT 300KG Load (Pair)	25mm Lift

REPLACEMENT BUSHINGS

PART NO.	Qty	DESCRIPTION	NOTES
QUANTITY PER SHOCK			
ADJ300/50	1	Suit Bottom Front Eye	Eyering Bonded Bushing
404702	1	Suit Top Rear Eyering	Eyering Bushing
TW038-6	1	Suit Bottom Rear Eyering	Eyering Bushing

PLEASE NOTE:

Use of **CONSTANT** load spring without load will result in tailshaft vibration.



MITSUBISHI

L200 4WD - MA, MB, MC, MD

05/1979-1986



FRONT SUSPENSION

ESTIMATED LIFT: 40mm

PART NO.	Qty	DESCRIPTION	NOTES
TORSION BARS			
4WTB-1726	1	Replacement Torsion Bars (Pair)	26mm/1277.5mm - SC, SD, SE
Adjust Torsion bars after fitting shocks - Ensure a minimum of 60mm droop is maintained			

REAR SUSPENSION

PART NO.	Qty	DESCRIPTION	NOTES
SHOCK ABSORBERS			
BD1382T	2	Nitrogen Gas Shock	Suit OE Height
FC41382	2	Foam Cell Shock	
BM401382	2	40mm Adjustable Shock	
BD1388T	2	Nitrogen Gas Shock	Suit 40mm Lift
FC41388	2	Foam Cell Shock	
BM401388	2	40mm Adjustable Shock	
ADDITIONAL COMPONENTS			
TDUK-021/35	1	Urethane Shackle Bushing Kit	
TDUB-006	2	U-Bolt Kit	

REPLACEMENT BUSHINGS

PART NO.	Qty	DESCRIPTION	NOTES
QUANTITY PER SHOCK			
404702	2	Suit Top & Bottom Rear Eying	Eying Bushing

Fitting sheet (located page 243) must be completed when suspension fitted. Failure to comply may affect warranty.



MITSUBISHI

L300 4WD - SC, SD, SE, SF, SG, SH

05/1983-1994



FRONT SUSPENSION

ESTIMATED LIFT: 40mm

PART NO.	Qty	DESCRIPTION	NOTES
SHOCK ABSORBERS			
BD2058T	2	Nitrogen Gas Shock	
FC42058B	2	Foam Cell Shock	Suit Up To 40mm Lift
TORSION BARS			
4WTB-1726	1	Replacement Torsion Bars (Pair)	26mm/1277.5mm - SC, SD, SE
Adjust Torsion bars after fitting shocks - Ensure a minimum of 60mm droop is maintained			

REAR SUSPENSION

PART NO.	Qty	DESCRIPTION	NOTES
SHOCK ABSORBERS			
BD1366T	2	Nitrogen Gas Shock	
FC41366	2	Foam Cell Shock	Suit OE Height SC, SD, SE ONLY
BM401366	2	40mm Adjustable Shock	
BD1382T	2	Nitrogen Gas Shock	
FC41382	2	Foam Cell Shock	Suit 40mm Lift SC, SD, SE ONLY
BM401382	2	40mm Adjustable Shock	
BD1386T	2	Nitrogen Gas Shock	
FC41386	2	Foam Cell Shock	Suit OE Height SF, SG, SH ONLY
BM401386	2	40mm Adjustable Shock	
BD1400T	2	Nitrogen Gas Shock	
FC41400	2	Foam Cell Shock	Suit 40mm Lift SF, SG, SH ONLY
BM401400	2	40mm Adjustable Shock	
ADDITIONAL COMPONENTS			
TDUK-005	1	Urethane Shackle Bushing Kit	
TDUB-006	2	U-Bolt Kit	

REPLACEMENT BUSHINGS

PART NO.	Qty	DESCRIPTION	NOTES
QUANTITY PER SHOCK			
TW959	2	Suit Top Front Pin	Pin Style Bushing
404702	2	Suit Top & Bottom Rear Eying	Eying Bushing #1366 & #1382
404702	1	Suit Top & Bottom Rear Eying	Eying Bushing #1386 & #1400
TW959	2	Suit Bottom Rear Pin	Pin Style Bushing #1386 & 1400

All prices exclude freight. Include only permanent accessories & weights when selecting springs. Towing weight is not included.



FRONT SUSPENSION

ESTIMATED LIFT: 40mm

PART NO.	Qty	DESCRIPTION	NOTES
SHOCK ABSORBERS			
FC42058B	2	Foam Cell Shock (Bar Pin)	40mm Lift (NA-NG ONLY)
FC42057B	2	Foam Cell Shock (Sleeve)	40mm Lift (NH ONLY)
TORSION BARS			
4WTB-1726	1	Replacement Torsion Bars (Pair)	26mm/1277.5mm
Adjust Torsion bars after fitting shocks - Ensure a minimum of 60mm droop is maintained			
STEERING DAMPERS			
SS5013-P/S	1	Return To Centre Damper	Damper Mounts Present In Vehicle
SS5016-P/S	1	Return To Centre Damper	Mounts Not Present In Vehicle

REAR SUSPENSION

PART NO.	Qty	DESCRIPTION	NOTES
SHOCK ABSORBERS			
FC41382	2	Foam Cell Shock	Suit Up To 40mm Lift
BM401382	2	40mm Adjustable Shock	Suit Up To 40mm Lift
LEAF SPRINGS			
FS021	2	0-300KG Load	40mm Lift
FS021H	2	CONSTANT 300KG Load	40mm Lift
ADDITIONAL COMPONENTS			
TDUK-005	1	Urethane Shackle Bushing Kit	
TDUB-006	2	U-Bolt Kit	
TDGP-004	1	Greasable Pin Kit	
TDGS-900	1	Greasable Shackle Kit	

REPLACEMENT BUSHINGS

PART NO.	Qty	DESCRIPTION	NOTES
QUANTITY PER SHOCK			
TW959	2	Suit Top Front Pin	Pin Style Bushing
404702	2	Suit Top & Bottom Rear Eying	Eying Bushing
412772	1	Suit Bottom Front Eying	Eying Bushing #2057B ONLY

Fitting sheet (located page 243) must be completed when suspension fitted. Failure to comply may affect warranty.



FRONT SUSPENSION

ESTIMATED LIFT: 40mm

PART NO.	Qty	DESCRIPTION	NOTES
SHOCK ABSORBERS			
FC42058B	2	Foam Cell Shock	40mm Lift (NF-NG ONLY)
FC42057B	2	Foam Cell Shock	40mm Lift (NH-NL ONLY)
TORSION BARS			
4WTB-1726	1	Replacement Torsion Bars (Pair)	26mm/1277.5mm (91-05/96)
4WTB-0203	1	Replacement Torsion Bars (Pair)	27.5mm/1307mm (06/96-00)
Adjust Torsion bars after fitting shocks - Ensure a minimum of 60mm droop is maintained			
STEERING DAMPERS			
SS5013-P/S	1	Return To Centre Damper	Damper Mounts Present In Vehicle
SS5016-P/S	1	Return To Centre Damper	Mounts Not Present In Vehicle

REAR SUSPENSION

PART NO.	Qty	DESCRIPTION	NOTES
SHOCK ABSORBERS			
FC41439	2	Foam Cell Shock	Up To 40mm Lift (NF-NG ONLY)
BM401439	2	40mm Adjustable Shock	Up To 40mm Lift (NF-NG ONLY)
FC41170B	2	Foam Cell Shock	Suit OE Height (NH-NL ONLY)
BM401170	2	40mm Adjustable Shock	Suit OE Height (NH-NL ONLY)
FC41178B	2	Foam Cell Shock	Up To 40mm Lift (NH-NL ONLY)
BM401178	2	40mm Adjustable Shock	Up To 40mm Lift (NH-NL ONLY)
COIL SPRINGS			
TDC632SL	1	0-300KG Load (Pair)	40mm Lift
TDC632L	1	CONSTANT 300KG Load (Pair)	40mm Lift

REPLACEMENT BUSHINGS

PART NO.	Qty	DESCRIPTION	NOTES
QUANTITY PER SHOCK			
TW959	2	Suit Top Front Pin	Pin Style Bushing
412772	1	Suit Bottom Front Eye	Eyering Bushing #2057B
402267	2	Suit Top Pin Mount Rear	
TW038-16	2	Suit Bottom Rear	



MITSUBISHI

PAJERO/MONTERO - NM-NX

05/1979-1986



FRONT SUSPENSION

ESTIMATED LIFT: 40mm

PART NO.	Qty	DESCRIPTION	NOTES
SHOCK ABSORBERS			
FC404300	2	Foam Cell Strut	
BM404300	2	40mm Adjustable Shock	9 Stage Adjustable
COIL SPRINGS			
TDC631	1	OE Height Spring (Pair)	
TDC633	1	40mm Lift Spring (Pair)	Petrol/Bar
TDC633L	1	40mm Lift Spring (Pair)	Diesel/Bar
TDC633H	1	40mm Lift Spring (Pair)	Petrol/Diesel/Bar/Winch
COMPLETE STRUT ASSEMBLY			
MIT-050/01	2	BM404300/TDC633	Petrol/Bar
MIT-050/02	2	BM404300/TDC633L	Diesel/Bar
MIT-050/03	2	BM404300/TDC633H	Petrol/Diesel/Bar/Winch
MIT-050/04	2	FC404300/TDC633	Petrol/Bar
MIT-050/05	2	FC404300/TDC633L	Diesel/Bar
MIT-050/06	2	FC404300/TDC633H	Petrol/Diesel/Bar/Winch
ADDITIONAL COMPONENTS			
MIT-4038	2	Strut Top	Replacement Strut Top

REPLACEMENT BUSHINGS

PART NO.	Qty	DESCRIPTION	NOTES
QUANTITY PER SHOCK			
ADJ300/40A	1	Suit Bottom Front Eying	Eying Bonded Bushing
TW959	2	Suit Top Rear Pin	Pin Style Bushing
4W-BS101CH	1	Suit Bottom Rear Eying	Eying Bushing

Fitting sheet (located page 243) must be completed when suspension fitted. Failure to comply may affect warranty.



MITSUBISHI

PAJERO/MONTERO - NM-NX

05/2000 ON



REAR SUSPENSION

ESTIMATED LIFT: 40mm

PART NO.	Qty	DESCRIPTION	NOTES
SHOCK ABSORBERS			
FC41148	2	Foam Cell Shock	Suit Up To 40mm Lift
COIL SPRINGS			
TDC635S	1	0-300KG Load (Pair)	OE Height (LWB) 40mm Lift (SWB)
TDC635	1	CONSTANT 300KG Load (Pair)	OE Height (LWB) 40mm Lift (SWB)
TDC635	1	0-300KG Load (Pair)	40mm Lift (LWB)
TDC635H	1	CONSTANT 300KG Load (Pair)	40mm Lift (LWB)
TDC635HH	1	CONSTANT 500KG Load (Pair)	40mm Lift (LWB)
AIR ASSIST BAGS			
TDAA-006	1	Coil Insert Bag Kit	Suit 40mm Lift
TDAA-012	1	Coil Insert Bag Kit	Suit Standard Height ONLY

All prices exclude freight. Include only permanent accessories & weights when selecting springs. Towing weight is not included.



FRONT SUSPENSION

ESTIMATED LIFT: 20mm

PART NO.	Qty	DESCRIPTION	NOTES
SHOCK ABSORBERS			
FC404800	2	Foam Cell Strut	
BM404800	2	40mm Adjustable Strut	9 Stage Adjustable
COIL SPRINGS			
TDC681	1	20mm Lift Spring (Pair)	Diesel
TDC681L	1	20mm Lift Spring (Pair)	Diesel/Bar
TDC681HL	1	20mm Lift Spring (Pair)	Diesel/Bar/Winch
COMPLETE STRUT ASSEMBLY			
MIT-061/01	2	BM404800/TDC681	Diesel
MIT-061/02	2	BM404800/TDC681L	Diesel/Bar
MIT-061/03	2	BM404800/TDC681HL	Diesel/Bar/Winch
MIT-061/04	2	FC404800/TDC681	Diesel
MIT-061/05	2	FC404800/TDC681L	Diesel/Bar
MIT-061/06	2	FC404800/TDC681HL	Diesel/Bar/Winch
ADDITIONAL COMPONENTS			
MIT-4040	2	Strut Top	Replacement Strut Top

REAR SUSPENSION

PART NO.	Qty	DESCRIPTION	NOTES
SHOCK ABSORBERS			
FC41440B	2	Foam Cell Shock	Suit Up To 20mm Lift
BM401440	2	40mm Adjustable Shock	Suit Up To 20mm Lift
COIL SPRINGS			
TDC638L	1	0-300KG Load (Pair)	20mm Lift
TDC638HL	1	CONSTANT 300KG Load (Pair)	20mm Lift
AIR ASSIST BAGS			
TDAA-001	1	Coil Insert Bag Kit	Suit 20mm Lift
TDAA-015	1	Coil Insert Bag Kit	Suit Standard Height Only

PLEASE NOTE:

Use of CONSTANT load spring without load will result in tailshaft vibration.

REPLACEMENT BUSHINGS

PART NO.	Qty	DESCRIPTION	NOTES
QUANTITY PER SHOCK			
ADJ300/50	1	Suit Bottom Front Eying	Eying Bonded Bushing
404702	1	Suit Top Rear Eying	Eying Bushing
TW038-16	1	Suit Bototm Rear Eying	Eying Bushing

Fitting sheet (located page 243) must be completed when suspension fitted. Failure to comply may affect warranty.



FRONT SUSPENSION

ESTIMATED LIFT: 40mm

PART NO.	Qty	DESCRIPTION	NOTES
SHOCK ABSORBERS			
BD2058T	2	Nitrogen Gas Shock	Up To 40mm Lift - Up To MK
BD2057T	2	Nitrogen Gas Shock	Up To 40mm Lift - MK ONLY
FC42057B	2	Foam Cell Shock	Up To 40mm Lift - MK ONLY
TORSION BARS			
4WTB-1726	1	Replacement Torsion Bars (Pair)	26mm/1277.5mm
4WTB-1736	1	Replacement Torsion Bars (Pair)	26mm/1370mm
<u>Check Bars First - Adjust Torsion bars after fitting shocks - Ensure a minimum of 60mm droop is maintained</u>			

PLEASE NOTE:

Some special edition models are equipped with H/Duty leaf packs from factory - Check prior to ordering.

REAR SUSPENSION

PART NO.	Qty	DESCRIPTION	NOTES
SHOCK ABSORBERS			
BD1388T	2	Nitrogen Gas Shock	Suit Up To 40mm Lift
FC41388	2	Foam Cell Shock	Suit Up To 40mm Lift
BM401388	2	40mm Adjustable Shock	Suit Up To 40mm Lift
LEAF SPRINGS			
FS021	2	0-300KG Load	40mm Lift
FS021H	2	CONSTANT 300KG Load	40mm Lift
ADDITIONAL COMPONENTS			
TDSK-023	1	Anti Inversion Kit	MUST be fitted with ALL Leaf Springs
TDUK-021/31	1	Urethane Shackle Bushing Kit	
TDUB-006	2	U-Bolt Kit	
TDGS-900	1	Greasable Shackle Kit	

REPLACEMENT BUSHINGS

PART NO.	Qty	DESCRIPTION	NOTES
QUANTITY PER SHOCK			
TW959	2	Suit Top Front Pin	Pin Style Bushing
412772	1	Suit Bottom Front Eye	Eyering Bushing #2057
404702	2	Suit Top & Bottom Rear Eye	Eyering Bushing



FRONT SUSPENSION

ESTIMATED LIFT: 25mm

PART NO.	Qty	DESCRIPTION	NOTES
SHOCK ABSORBERS			
FC404800	2	Foam Cell Strut	
BM404800	2	40mm Adjustable Strut	9 Stage Adjustable
COIL SPRINGS			
TDC670	1	25mm Lift Spring (Pair)	Petrol/Diesel/Bar
TDC670H	1	25mm Lift Spring (Pair)	Petrol/Diesel/Bar/Winch
COMPLETE STRUT ASSEMBLY			
MIT-060/01	2	BM404800/TDC670	Petrol/Diesel/Bar
MIT-060/02	2	BM404800/TDC670H	Petrol/Diesel/Bar/Winch
MIT-060/03	2	FC404800/TDC670	Petrol/Diesel/Bar
MIT-060/04	2	FC404800/TDC670H	Petrol/Diesel/Bar/Winch
ADDITIONAL COMPONENTS			
MIT-4040	2	Strut Top	Replacement Strut

REPLACEMENT BUSHINGS

PART NO.	Qty	DESCRIPTION	NOTES
QUANTITY PER SHOCK			
ADJ300/50	1	Suit Bottom Front Eying	Eying Bushing (FC & BM)
404702	2	Suit Top & Bottom Rear Eying	Eying Bushing (Foam Cell)
TW038-16	1	Suit Top Rear Eying	Eying Bushing (Adjustable)
404702	1	Suite Bottom Rear Eying	Eying Bushing (Adjustable)

Fitting sheet (located page 243) must be completed when suspension fitted. Failure to comply may affect warranty.



MITSUBISHI

TRITON - ML-MN

07/2006-2015



REAR SUSPENSION

ESTIMATED LIFT: 25mm

PART NO.	Qty	DESCRIPTION	NOTES
SHOCK ABSORBERS			
BD1383T	2	Nitrogen Gas Shock	Suit Up To 25mm Lift
FC41383	2	Foam Cell Shock	Suit Up To 25mm Lift
BM401383	2	40mm Adjustable Shock	Suit Up To 25mm Lift
LEAF SPRINGS			
FS122C	2	0-300KG Load	25mm Lift
FS122L	2	CONSTANT 300KG Load	25mm Lift
FS122LL	2	CONSTANT 500KG Load	25mm Lift
ADDITIONAL COMPONENTS			
TDUK-021/41	1	Urethane Shackle Bushing Kit	Suit OEM Spring ONLY
TDUK-021/31	1	Urethane Shackle Bushing Kit	Suit Tough Dog Spring ONLY
TDUB-036	2	U-Bolt Kit	
TDGS-900	1	Greasable Shackle Kit	
AIR ASSIST BAGS			
TDAA-105	1	Bellows Bag Kit	Suit 25mm Lift

PLEASE NOTE:

Due to excessive overhang created by the design of the Mitsubishi Tritons, vehicles carrying greater than 600KG Load constantly in the rear should be fitted with a front spring one specification lighter than normal specification - this would guard against 'see saw' effect at the rear of the vehicle. Failure to observe will result in leaf spring riding lower than desired height and potential front shock damage.





FRONT SUSPENSION

ESTIMATED LIFT: 20mm

PART NO.	Qty	DESCRIPTION	NOTES
SHOCK ABSORBERS			
FC404800	2	Foam Cell Strut	
BM404800	2	40mm Adjustable Strut	9 Stage Adjustable
COIL SPRINGS			
TDC681	1	20mm Lift Spring (Pair)	Diesel
TDC681L	1	20mm Lift Spring (Pair)	Diesel/Bar
TDC681HL	1	20mm Lift Spring (Pair)	Diesel/Bar/Winch
COMPLETE STRUT ASSEMBLY			
MIT-061/01	2	BM404800/TDC681	Diesel
MIT-061/02	2	BM404800/TDC681L	Diesel/Bar
MIT-061/03	2	BM404800/TDC681HL	Diesel/Bar/Winch
MIT-061/05	2	FC404800/TDC681	Diesel
MIT-061/06	2	FC404800/TDC681L	Diesel/Bar
MIT-061/07	2	FC404800/TDC68HL	Diesel/Bar/Winch
ADDITIONAL COMPONENTS			
MIT-4040	2	Strut Top	Replacement Strut Top

REPLACEMENT BUSHINGS

PART NO.	Qty	DESCRIPTION	NOTES
QUANTITY PER SHOCK			
ADJ300/50	1	Suit Bottom Front Eying	Eying Bonded Bushing
404702	1	Suit Top Rear Eying	Eying Bushing
TW038-16	1	Suit Bottom Rear Eying	Eying Bushing

Fitting sheet (located page 243) must be completed when suspension fitted. Failure to comply may affect warranty.



REAR SUSPENSION

ESTIMATED LIFT: 20mm

PART NO.	Qty	DESCRIPTION	NOTES
SHOCK ABSORBERS			
BD3012T	2	Nitrogen Gas Shock	Suit Up To 20mm Lift
FC43012	2	Foam Cell Shock	Suit Up To 20mm Lift
BM403012	2	40mm Adjustable Shock	Suit Up To 20mm Lift
LEAF SPRINGS			
FS123C	2	0-300KG Load	20mm Lift
FS123L	2	CONSTANT 300KG Load	20mm Lift
FS123LL	2	CONSTANT 500KG Load	20mm Lift
ADDITIONAL COMPONENTS			
TDUK-077	1	Urethane Shackle Bushing Kit	
TDUB-016	2	U-Bolt Kit	
TDGS-901	1	Greasable Shackle Kit	
TDGP-668	1	Greasable Pin Kit	
TDSP-008	1	Centre Bearing Strengthening Kit	Required with ALL Lift Kits
AIR ASSIST BAGS			
TDAA-106	1	Bellows Bag Kit	Suit 20mm Lift
TDAA-119	1	Bellows Bag Kit	Suit Standard Height ONLY

PLEASE NOTE:

Due to excessive overhang created by the design of the Mitsubishi Tritons, vehicles carrying greater than 600KG Load constantly in the rear should be fitted with a front spring one specification lighter than normal specification - this would guard against 'see saw' effect at the rear of the vehicle. Failure to observe will result in leaf spring riding lower than desired height and potential front shock damage.



MITSUBISHI

TRITON - MR

11/2018 ON



FRONT SUSPENSION

ESTIMATED LIFT: 20mm

PART NO.	Qty	DESCRIPTION	NOTES
SHOCK ABSORBERS			
FC404800	2	Foam Cell Strut	
BM404800	2	40mm Adjustable Strut	9 Stage Adjustable
COIL SPRINGS			
TDC1029	1	20mm Lift Spring (Pair)	Diesel
TDC1030	1	20mm Lift Spring (Pair)	Diesel/Bar
TDC1031	1	20mm Lift Spring (Pair)	Diesel/Bar/Winch
COMPLETE STRUT ASSEMBLY			
MIT-001	2	BM404800/TDC1023	Diesel
MIT-002	2	BM404800/TDC1030	Diesel/Bar
MIT-003	2	BM404800/TDC1031	Diesel/Bar/Winch
MIT-004	2	FC404800/TDC1029	Diesel
MIT-005	2	FC404800/TDC1030	Diesel/Bar
MIT-006	2	FC404800/TDC1031	Diesel/Bar/Winch
ADDITIONAL COMPONENTS			
MIT-4040	2	Strut Top	Replacement Strut Top

REPLACEMENT BUSHINGS

PART NO.	Qty	DESCRIPTION	NOTES
QUANTITY PER SHOCK			
ADJ300/50	1	Suit Bottom Front Eying	Eying Bonded Bushing
404702	1	Suit Top Rear Eying	Eying Bushing
TW038-16	1	Suit Bottom Rear Eying	Eying Bushing

Fitting sheet (located page 243) must be completed when suspension fitted. Failure to comply may affect warranty.



REAR SUSPENSION

ESTIMATED LIFT: 20mm

PART NO.	Qty	DESCRIPTION	NOTES
SHOCK ABSORBERS			
BD3012T	2	Nitrogen Gas Shock	Suit Up To 20mm Lift
FC43012	2	Foam Cell Shock	Suit Up To 20mm Lift
BM403012	2	40mm Adjustable Shock	Suit up To 20mm Lift
LEAF SPRINGS			
FS123C	2	0-300KG Load	20mm Lift
FS123L	2	CONSTANT 300KG Load	20mm Lift
FS123LL	2	CONSTANT 500KG Load	20mm Lift
ADDITIONAL COMPONENTS			
TDUK-077	1	Urethane Shackle Bushing Kit	
TDUB-016	2	U-Bolt Kit	
TDGS-901	1	Greasable Shackle Kit	
TDGP-668	1	Greasable Pin Kit	
TDSP-008	1	Centre Bearing Strengthening Kit	Required with ALL Lift Kits
AIR ASSIST BAGS			
TDAA-106	1	Bellows Bag Kit	Suit 20mm Lift
TDAA-119	1	Bellows Bag Kit	Suit Standard Height ONLY

PLEASE NOTE:

Due to excessive overhang created by the design of the Mitsubishi Tritons, vehicles carrying greater than 600KG Load constantly in the rear should be fitted with a front spring one specification lighter than normal specification - this would guard against 'see saw' effect at the rear of the vehicle. Failure to observe will result in leaf spring riding lower than desired height and potential front shock damage.



FRONT SUSPENSION

ESTIMATED LIFT: 40mm

PART NO.	Qty	DESCRIPTION	NOTES
SHOCK ABSORBERS			
FC42052B	2	Foam Cell Shock	Up To 40mm Lift
TORSION BARS			
4WTB-1456	1	Replacement Torsion Bars (Pair)	26mm/1203mm (86-97 ONLY)
4WTB-1446	1	Replacement Torsion Bars (Pair)	26mm/890mm (97 On ONLY)
<u>Check Bars First - Adjust Torsion bars after fitting shocks - Ensure a minimum of 60mm droop is maintained</u>			
STEERING DAMPERS			
SD14035	1	Heavy Duty Replacement Damper	Suit D21 ONLY
EXT5925	1	Heavy Duty Replacement Damper	
SS5925-P/S	1	Return To Centre Damper	Suit D22 ONLY
SV5925	1	9 Stage Adjustable Damper	

REPLACEMENT BUSHINGS

PART NO.	Qty	DESCRIPTION	NOTES
QUANTITY PER SHOCK			
TW959	2	Suit Front Top Pin	Pin Style Bushing
412773	1	Suit Front Bottom Eye	Eyering Bushing
404702	2	Suit Top & Bottom Rear Eye	Eyering Bushing

Fitting sheet (located page 243) must be completed when suspension fitted. Failure to comply may affect warranty.



NISSAN

NAVARA - D21, D22

01/1996 - 2015



REAR SUSPENSION

ESTIMATED LIFT: 40mm

PART NO.	Qty	DESCRIPTION	NOTES
SHOCK ABSORBERS			
BD1366T	2	Nitrogen Gas Shock	
FC41366B	2	Foam Cell Shock	Suit OE Height
BM401366	2	40mm Adjustable Shock	
BD1382T	2	Nitrogen Gas Shock	
FC41382B	2	Foam Cell Shock	Suit 40mm Lift
BM401382	2	40mm Adjustable Shock	
LEAF SPRINGS			
1 Left Hand Side and 1 Right Hand Side leaf spring pack should be ordered			
T63-LH	1	0-300KG Load	40mm Lift Left Hand Side
T63-RH	1	0-300KG Load	40mm Lift Right Hand Side
T63H	2	CONSTANT 300KG Load	40mm Lift
ADDITIONAL COMPONENTS			
TDUK-007	1	Urethane Shackle Bushing Kit	
TDUB-012	2	U-Bolt Kit	
TDGS-668	1	Greasable Shackle Kit	
TDGP-669	1	Greasable Pin Kit	
AIR ASSIST BAGS			
TDAA-107	1	Bellows Bag Kit	Suit 40mm Lift (D22 ONLY)
TDAA-124	1	Bellows Bag Kit	Suit Standard Height (D22 ONLY)

All prices exclude freight. Include only permanent accessories & weights when selecting springs. Towing weight is not included.





NISSAN

NAVARA - D40 - 2.5L, 4.0L 12/2005-2015



FRONT SUSPENSION

ESTIMATED LIFT: 40mm

PART NO.	Qty	DESCRIPTION	NOTES
SHOCK ABSORBERS			
FC404700	2	Foam Cell Strut	
BM404700	2	40mm Adjustable Strut	9 Stage Adjustable
COIL SPRINGS			
TDC770	1	40mm Lift Spring (Pair)	Petrol/Diesel Bar
TDC770H	1	40mm Lift Spring (Pair)	Petrol/Diesel/Bar/Winch
COMPLETE STRUT ASSEMBLY			
NIS-040/01	2	BM404700/TDC770	Petrol/Diesel/Bar
NIS-040/02	2	BM404700/TDC770H	Petrol/Diesel/Bar/Winch
NIS-040/04	2	FC404700/TDC770	Petrol/Diesel/Bar
NIS-040/05	2	FC404700/TDC770H	Petrol/Diesel/Bar/Winch
ADDITIONAL COMPONENTS			
NIS-3030	2	Strut Top	Replacement Strut Top

REPLACEMENT BUSHINGS

PART NO.	Qty	DESCRIPTION	NOTES
QUANTITY PER SHOCK			
ADJ300/40A	1	Suit Bottom Front Eying	Eying Bonded Bushing
404702	1	Suit Rear Top Eying	Eying Bushing
TW040-14	1	Suit Rear Bottom Eying	Eying Bushing

Fitting sheet (located page 243) must be completed when suspension fitted. Failure to comply may affect warranty.



NISSAN

NAVARA - D40 - 2.5L, 4.0L 12/2005-2015



REAR SUSPENSION

ESTIMATED LIFT: 40mm

PART NO.	Qty	DESCRIPTION	NOTES
SHOCK ABSORBERS			
BD1368T	2	Nitrogen Gas Shock	Up To 40mm Lift (Comfort Use)
FC41368	2	Foam Cell Shock	Up To 40mm Lift
BM401368	2	40mm Adjustable Shock	Up To 40mm Lift
LEAF SPRINGS			
T85C	2	0-300KG Load	40mm Lift
T85L	2	CONSTANT 300KG Load	40mm Lift
T85LL	2	CONSTANT 500KG Load	40mm Lift
ADDITIONAL COMPONENTS			
TDUK-068	1	Urethane Shackle Bushing Kit	
TDUB-016	2	U-Bolt Kit	
TDGS-667	1	Greasable Shackle Kit	
TDGP-668	1	Greasable Pin Kit	
AIR ASSIST BAGS			
TDAA-108	1	Bellows Bag Kit	Suit 40mm Lift
TDAA-120	1	Bellows Bag Kit	Suit Standard Height ONLY

All prices exclude freight. Include only permanent accessories & weights when selecting springs. Towing weight is not included.



FRONT SUSPENSION

ESTIMATED LIFT: 40mm

PART NO.	Qty	DESCRIPTION	NOTES
SHOCK ABSORBERS			
FC404700	2	Foam Cell Strut	
BM404700	2	40mm Adjustable Strut	9 Stage Adjustable
COIL SPRINGS			
TDC772	1	40mm Lift Spring (Pair)	Petrol/Diesel/Bar
TDC772H	1	40mm Lift Spring (Pair)	Petrol/Diesel/Bar/Winch
COMPLETE STRUT ASSEMBLY			
NIS-040/06	2	BM404700/TDC772	Petrol/Diesel/Bar
NIS-040/03	2	BM404700/TDC772H	Petrol/Diesel/Bar/Winch
NIS-040/07	2	FC404700/TDC772	Petrol/Diesel/Bar
NIS-040/08	2	FC404700/TDC772H	Petrol/Diesel/Bar/Winch
ADDITIONAL COMPONENTS			
NIS-3030	2	Strut Top	Replacement Strut Top

REPLACEMENT BUSHINGS

PART NO.	Qty	DESCRIPTION	NOTES
QUANTITY PER SHOCK			
ADJ300/40A	1	Suit Bottom Front Eying	Eying Bonded Bushing
404702	1	Suit Rear Top Eying	Eying Bushing
TW040-14	1	Suit Rear Bottom Eying	Eying Bushing

Fitting sheet (located page 243) must be completed when suspension fitted. Failure to comply may affect warranty.



NISSAN

NAVARA - D40 - 3.0L STX-550 V6 2011 - 2015



REAR SUSPENSION

ESTIMATED LIFT: 40mm

PART NO.	Qty	DESCRIPTION	NOTES
SHOCK ABSORBERS			
BD1368T	2	Nitrogen Gas Shock	Up To 40mm Lift (Comfort Use)
FC41368	2	Foam Cell Shock	Up To 40mm Lift
BM401368	2	40mm Adjustable Shock	Up To 40mm Lift
LEAF SPRINGS			
T85C	2	0-300KG Load	40mm Lift
T85L	2	CONSTANT 300KG Load	40mm Lift
T85LL	2	CONSTANT 500KG Load	40mm Lift
ADDITIONAL COMPONENTS			
TDUK-068	1	Urethane Shackle Bushing Kit	
TDUB-016	2	U-Bolt Kit	
TDGS-667	1	Greasable Shackle Kit	
TDGP-668	1	Greasable Pin Kit	
AIR ASSIST BAGS			
TDAA-108	1	Bellows Bag Kit	Suit 40mm Lift
TDAA-120	1	Bellows Bag Kit	Suit Standard Height ONLY

All prices exclude freight. Include only permanent accessories & weights when selecting springs. Towing weight is not included.





FRONT SUSPENSION

ESTIMATED LIFT: 35mm

PART NO.	Qty	DESCRIPTION	NOTES
SHOCK ABSORBERS			
FC404710	2	Foam Cell Strut	
BM404710	2	40mm Adjustable Strut	9 Stage Adjustable
COIL SPRINGS			
TDC773	1	35mm Lift Spring (Pair)	Petrol/Diesel/Bar
TDC773H	1	35mm Lift Spring (Pair)	Petrol/Diesel/Bar/Winch
COMPLETE STRUT ASSEMBLY			
NIS-300/05	2	BM404710/TDC773	Petrol/Diesel/Bar
NIS-300/06	2	BM404710/TDC773H	Petrol/Diesel/Bar/Winch
NIS-300/07	2	FC404710/TDC773	Petrol/Diesel/Bar
NIS-300/08	2	FC404710/TDC773H	Petrol/Diesel/Bar/Winch
ADDITIONAL COMPONENTS			
NIS-3030	2	Strut Top	Replacement Strut Top

REAR SUSPENSION

PART NO.	Qty	DESCRIPTION	NOTES
SHOCK ABSORBERS			
FC41369	2	Foam Cell Shock	Up To 35mm Lift
BM401369	2	40mm Adjustable Shock	Up To 35mm Lift
COIL SPRINGS			
TDC774	1	0-300KG Load (Pair)	35mm Lift
TDC774H	1	CONSTANT 300KG Load (Pair)	35mm Lift
TDC774VHL	1	CONSTANT 500KG Load (Pair)	35mm Lift
ADDITIONAL COMPONENTS			
TDPR-300	1	Adjustable Panhard Rod	
AIR ASSIST BAGS			
TDAA-007	1	Coil Insert Bag Kit	Suit 35mm Lift
TDAA-016	1	Coil Insert Bag Kit	Suit Standard Height ONLY

REPLACEMENT BUSHINGS

PART NO.	Qty	DESCRIPTION	NOTES
QUANTITY PER SHOCK			
ADJ300/40A	1	Suit Bottom Front Eying	Eying Bonded Bushing
TW038-16	1	Suit Rear Top Eying	Eying Bushing
TW040-14	1	Suit Rear Bottom Eying	Eying Bushing

Fitting sheet (located page 243) must be completed when suspension fitted. Failure to comply may affect warranty.



NISSAN

NAVARA - NP300 COIL REAR (S5) 11/2020 ON



FRONT SUSPENSION

ESTIMATED LIFT: 20mm

PART NO.	Qty	DESCRIPTION	NOTES
SHOCK ABSORBERS			
FC404710	2	Foam Cell Strut	
BM404710	2	40mm Adjustable Strut	9 Stage Adjustable
COIL SPRINGS			
TDC773	1	20mm Lift Spring (Pair)	Petrol/Diesel No Accessories
TDC773H	1	20mm Lift Spring (Pair)	Petrol/Diesel/Bar/Bar & Winch
COMPLETE STRUT ASSEMBLY			
NIS-300/05	2	BM404710/TDC773	Petrol/Diesel No Accessories
NIS-300/06	2	BM404710/TDC773H	Petrol/Diesel/Bar/Bar & Winch
NIS-300/07	2	FC404710/TDC773	Petrol/Diesel No accessories
NIS-300/08	2	FC404710/TDC773H	Petrol/Diesel/Bar/Bar & Winch
ADDITIONAL COMPONENTS			
NIS-3030	2	Strut Top	Replacement Strut Top

REAR SUSPENSION

PART NO.	Qty	DESCRIPTION	NOTES
SHOCK ABSORBERS			
FC41369	2	Foam Cell Shock	Up To 20mm Lift
BM401369	2	40mm Adjustable Shock	Up To 20mm Lift
COIL SPRINGS			
TDC774H	1	0-300KG Load (Pair)	20mm Lift
TDC774VHL	1	CONSTANT 300KG Load (Pair)	20mm Lift
TDC1037	1	CONSTANT 500KG Load (Pair)	20mm Lift
ADDITIONAL COMPONENTS			
TDPR-300	1	Adjustable Panhard Rod	
AIR ASSIST BAGS			
TDAA-007	1	Coil Insert Bag Kit	Suit 35mm Lift
TDAA-016	1	Coil Insert Bag Kit	Suit Standard Height ONLY

REPLACEMENT BUSHINGS

PART NO.	Qty	DESCRIPTION	NOTES
QUANTITY PER SHOCK			
ADJ300/40A	1	Suit Bottom Front Eying	Eying Bonded Bushing
TW038-16	1	Suit Rear Top Eying	Eying Bushing
TW040-14	1	Suit Rear Bottom Eying	Eying Bushing

All prices exclude freight. Include only permanent accessories & weights when selecting springs. Towing weight is not included.



FRONT SUSPENSION

ESTIMATED LIFT: 35mm

PART NO.	Qty	DESCRIPTION	NOTES
SHOCK ABSORBERS			
FC404710	2	Foam Cell Strut	
BM404710	2	40mm Adjustable Strut	
COIL SPRINGS			
TDC773	1	35mm Lift Spring (Pair)	Petrol/Diesel/Bar
TDC773H	1	35mm Lift Spring (Pair)	Petrol/Diesel/Bar/Winch
COMPLETE STRUT ASSEMBLY			
NIS-300/05	2	BM404710/TDC773	Petrol/Diesel/Bar
NIS-300/06	2	BM404710/TDC773H	Petrol/Diesel/Bar/Winch
NIS-300/07	2	FC404710/TDC773	Petrol/Diesel/Bar
NIS-300/08	2	FC404710/TDC773H	Petrol/Diesel/Bar/Winch
ADDITIONAL COMPONENTS			
NIS-3030	2	Strut Top	Replacement Strut Top

REAR SUSPENSION

PART NO.	Qty	DESCRIPTION	NOTES
SHOCK ABSORBERS			
FC43017	2	Foam Cell Shock	Up To 35mm Lift
BM403017	2	40mm Adjustable Shock	Up To 35mm Lift
LEAF SPRINGS			
T86C	2	0-300KG Load	35mm Lift
T86L	2	CONSTANT 300KG Load	35mm Lift
T86LL	2	CONSTANT 500KG Load	35mm Lift
ADDITIONAL COMPONENTS			
TDUK-079	1	Urethane Shackle Bushing Kit	
TDUB-005	2	U-Bolt Kit	
TDGS-669	1	Greasable Shackle Kit	
TDGP-668	1	Greasable Pin Kit	
AIR ASSIST BAGS			
TDAA-109	1	Bellows Bag Kit	Suit Up To 35mm Lift

REPLACEMENT BUSHINGS

PART NO.	Qty	DESCRIPTION	NOTES
QUANTITY PER SHOCK			
ADJ300/40A	1	Suit Bottom Front Eying	Eying Bonded Bushing
404702	1	Suit Rear Top Eying	Eying Bushing
404702	1	Suit Rear Bottom Eying	Eying Bushing

Fitting sheet (located page 243) must be completed when suspension fitted. Failure to comply may affect warranty.



FRONT SUSPENSION

ESTIMATED LIFT: 30mm

PART NO.	Qty	DESCRIPTION	NOTES
SHOCK ABSORBERS			
BD2057T	2	Nitrogen Gas Shock	Up To 30mm Lift
FC42057B	2	Foam Cell Shock	Up To 30mm Lift
TORSION BARS			
4WTB-1458	1	Replacement Torsion Bars	26mm/1232mm
Adjust Torsion bars after fitting shocks - Ensure a minimum of 60mm droop is maintained			
STEERING DAMPERS			
SD14035	1	Heavy Duty Replacement Damper	Suit D21 ONLY

REAR SUSPENSION

PART NO.	Qty	DESCRIPTION	NOTES
SHOCK ABSORBERS			
BD1382T	2	Nitrogen Gas Shock	Up To 30mm Lift
FC41382B	2	Foam Cell Shock	Up To 30mm Lift
BM401382	2	40mm Adjustable Shock	Up To 30mm Lift
COIL SPRINGS			
TDC739	1	0-300KG Load (Pair)	30mm Lift
TDC739H	1	CONSTANT 300KG Load (Pair)	30mm Lift

REPLACEMENT BUSHINGS

PART NO.	Qty	DESCRIPTION	NOTES
QUANTITY PER SHOCK			
TW959	2	Suit Front Top Pin Mount	Pin Style Bushing
412772	1	Suit Front Bottom Eying	Eying Bushing
404702	2	Suit Rear Top & Bottom Eying	Eying Bushing



FRONT SUSPENSION

ESTIMATED LIFT: 30mm

PART NO.	Qty	DESCRIPTION	NOTES
SHOCK ABSORBERS			
BDS4002R (D/S)	1	Twin Tube McPherson Strut	OE Height - Suit 11/1995-1999 ONLY
BDS4003L (P/S)	1	Twin Tube McPherson Strut	
BDS4024	2	Twin Tube McPherson Strut	Suit Up To 30mm (All Models)
COIL SPRINGS			
TDC784S	1	OE Height Lift Spring (Pair)	OE Height ONLY
TDC784	1	30mm Lift Spring (Pair)	Suit Up To Bar
TDC784H	1	30mm Lift Spring (Pair)	Suit Up To Bar/Winch

REAR SUSPENSION

PART NO.	Qty	DESCRIPTION	NOTES
SHOCK ABSORBERS			
BD3009T	2	Nitrogen Gas Shock	OE Height (Suit 11/1995-1999 ONLY)
FC43009	2	Foam Cell Shock	
BD3010T	2	Nitrogen Gas Shock	30mm Lift (Suit 11/1995-1999 ONLY)
FC43010	2	Foam Cell Shock	
BD3011T	2	Nitrogen Gas Shock	Up To 30mm Lift (Suit 11/1999-2005 ONLY)
FC43011	2	Foam Cell Shock	
COIL SPRINGS			
TDC783S	1	0-300KG Load (Pair)	OE Height
TDC783	1	0-300KG Load (Pair)	30mm Lift
TDC783H	1	CONSTANT 300KG Load (Pair)	30mm Lift

Fitting sheet (located page 243) must be completed when suspension fitted. Failure to comply may affect warranty.



FRONT SUSPENSION

ESTIMATED LIFT: 40mm

PART NO.	Qty	DESCRIPTION	NOTES
SHOCK ABSORBERS			
FC404700	2	Foam Cell Strut	
BM404700	2	40mm Adjustable Strut	9 Stage Adjustable
COIL SPRINGS			
TDC770	1	40mm Lift Spring (Pair)	Petrol/Diesel/Bar
TDC770H	1	40mm Lift Spring (Pair)	Petrol/Diesel/Bar/Winch
COMPLETE STRUT ASSEMBLY			
NIS-040/01	2	BM404700/TDC770	Petrol/Diesel/Bar
NIS-040/02	2	BM404700/TDC770H	Petrol/Diesel/Bar/Winch
NIS-040/04	2	FC404700/TDC770	Petrol/Diesel/Bar
NIS-040/05	2	FC404700/TDC770H	Petrol/Diesel/Bar/Winch
ADDITIONAL COMPONENTS			
NIS-3030	2	Strut Top	Replacement Strut Top

REAR SUSPENSION

PART NO.	Qty	DESCRIPTION	NOTES
SHOCK ABSORBERS			
FC41347	2	Foam Cell Shock	Up To 40mm Lift
BM401347	2	40mm Adjustable Shock	Up To 40mm Lift
COIL SPRINGS			
TDC771	1	0-300KG Load (Pair)	40mm Lift
TDC771H	1	CONSTANT 300KG Load (Pair)	40mm Lift
TDC771XHD	1	CONSTANT 500KG Load (Pair)	40mm Lift
AIR ASSIST BAGS			
TDAA-002	1	Coil Insert Bag Kit	Suit 40mm Lift
TDAA-018	1	Coil Insert Bag Kit	Suit 40mm Lift

REPLACEMENT BUSHINGS

PART NO.	Qty	DESCRIPTION	NOTES
QUANTITY PER SHOCK			
ADJ300/40A	1	Suit Front Bottom Eying	Eying Bnded Bushing
4W-BS101CH	2	Suit Top & Bottom Rear	



FRONT SUSPENSION

ESTIMATED LIFT: 40mm

PART NO.	Qty	DESCRIPTION	NOTES
SHOCK ABSORBERS			
FC404700	2	Foam Cell Strut	
BM404700	2	40mm Adjustable Strut	9 Stage Adjustable
COIL SPRINGS			
TDC772	1	40mm Lift Spring (Pair)	Petrol/Diesel/Bar
TDC772H	1	40mm Lift Spring (Pair)	Petrol/Diesel/Bar/Winch
COMPLETE STRUT ASSEMBLY			
NIS-040/06	2	BM404700/TDC772	Petrol/Diesel/Bar
NIS-040/03	2	BM404700/TDC772H	Petrol/Diesel/Bar/Winch
NIS-040/07	2	FC404700/TDC772	Petrol/Diesel/Bar
NIS-040/08	2	FC404700/TDC772H	Petrol/Diesel/Bar/Winch
ADDITIONAL COMPONENTS			
NIS-3030	2	Strut Top	Replacement Strut Top

REAR SUSPENSION

PART NO.	Qty	DESCRIPTION	NOTES
SHOCK ABSORBERS			
FC41347	2	Foam Cell Shock	Up To 40mm Lift
BM401347	2	40mm Adjustable Shock	Up To 40mm Lift
COIL SPRINGS			
TDC771	1	0-300KG Load (Pair)	40mm Lift
TDC771H	1	CONSTANT 300KG Load (Pair)	40mm Lift
TDC771XHD	1	CONSTANT 500KG Load (Pair)	40mm Lift
AIR ASSIST BAGS			
TDAA-002	1	Coil Insert Bag Kit	Suit 40mm Lift
TDAA-018	1	Coil Insert Bag Kit	Suit Standard Height ONLY

REPLACEMENT BUSHINGS

PART NO.	Qty	DESCRIPTION	NOTES
QUANTITY PER SHOCK			
ADJ300/40A	1	Suit Front Bottom Eying	Eying Bonded Bushing
4W-BS101CH	2	Suit Rear Top & Bottom Eying	

Fitting sheet (located page 243) must be completed when suspension fitted. Failure to comply may affect warranty.



THIS PAGE IS INTENTIONALLY BLANK



FRONT SUSPENSION

ESTIMATED LIFT: 40mm

PART NO.	Qty	DESCRIPTION	NOTES
SHOCK ABSORBERS			
BD1005T	2	Nitrogen Gas Shock	
FC41005	2	Foam Cell Shock	Suit OE Height
BM401005	2	40mm Adjustable Shock	
BD1007T	2	Nitrogen Gas Shock	
FC41007	2	Foam Cell Shock	Suit 40mm Lift
BM401007	2	40mm Adjustable Shock	
LEAF SPRINGS			
BPN-007	2	40mm Lift Spring	Petrol/Diesel/Bar
BPN-007H	2	40mm Lift Spring	Petrol/Diesel/Bar/Winch
STEERING DAMPERS			
EXT5005	1	Heavy Duty Replacement Damper	
SS5005-P/S	1	Return To Centre Damper	Suit Power Steering
SS5005-M/S	1	Return To Centre Damper	Suit Manual Steering
ADDITIONAL COMPONENTS			
TDUK-009	1	Urethane Shackle Bushing Kit	Must be fitted with TD Springs
TDUB-009	1	U-Bolt Kit	
TDUB-004	1	U-Bolt Kit	
TDGP-470	1	Greasable Pin Kit	
TDGS-355	1	Greasable Shackle Kit	Suit MQ with OE Springs
TDGS-665	1	Greasable Shackle Kit	Suit MQ, MK with TD Springs
NAK-005	1	Offset Kingpin	0.5 Degree
NAK-075	1	Offset Kingpin	0.75 Degree
NAK-001	1	Offset Kingpin	1.0 Degree

Fitting sheet (located page 243) must be completed when suspension fitted. Failure to comply may affect warranty.



REAR SUSPENSION

ESTIMATED LIFT: 40mm

PART NO.	Qty	DESCRIPTION	NOTES
SHOCK ABSORBERS			
BD1400T	2	Nitrogen Gas Shock	
FC41400	2	Foam Cell Shock	Suit OE Height
BM401400	2	40mm Adjustable Shock	
BD1441T	2	Nitrogen Gas Shock	
FC41441	2	Foam Cell Shock	Suit 40mm Lift
BM401441	2	40mm Adjustable Shock	
LEAF SPRINGS			
BPN-008	2	0-300KG Load	
BPN-008H	2	CONSTANT 300KG Load	
ADDITIONAL COMPONENTS			
TDUK-010	1	Urethane Shackle Bushing Kit	
TDUB-010	2	U-Bolt Kit	
TDGP-470	1	Greasable Pin Kit	
TDGS-664	1	Greasable Shackle Kit	

REPLACEMENT BUSHINGS

PART NO.	Qty	DESCRIPTION	NOTES
QUANTITY PER SHOCK			
TW959	4	Suit Front Top & Bottom Pin	Pin Style Bushing
TW959	2	Suit Rear Bottom Pin	Pin Style Bushing
404702	1	Suit Rear Top Eye	



FRONT SUSPENSION

ESTIMATED LIFT: 50mm

PART NO.	Qty	DESCRIPTION	NOTES
SHOCK ABSORBERS			
FC41047	2	Foam Cell Shock	Suit Up To 50mm Lift
BM401047	2	40mm 9 Stage Adjustable Shock	Suit Up To 50mm Lift
BMX1047/2	2	45mm 9 Stage Adjustable Shock	Suit 50mm Lift ONLY
TDR1047B	2	'Ralph' Shock	Suit Up To 50mm Lift
COIL SPRINGS			
TDC731	1	25mm Lift Coil (Pair)	Suit SWB/Alloy Bar
TDC734SL	1	25mm Lift Coil (Pair)	Suit LWB/Bar
TDC734HSL	1	25mm Lift Coil (Pair)	Suit LWB/Bar/Winch
TDC734CL	1	50mm Lift Coil (Pair)	Suit LWB with 2.8L/Alloy Bar
TDC734L	1	50mm Lift Coil (Pair)	Suit LWB/Bar
TDC734HL	1	50mm Lift Coil (Pair)	Suit LWB/Bar/Winch
STEERING DAMPERS			
EXT5612	1	Heavy Duty Replacement Damper	
SS5612-P/S	1	Return To Centre Damper	Suit 02/1988-08/1989 ONLY
SV5612	1	9 Stage Adjustable Damper	
EXT5613	1	Heavy Duty Replacement Damper	
SS5613-P/S	1	Return To Centre Damper	Suit 09/1989-1998 ONLY
SV5613	1	9 Stage Adjustable Damper	
CASTER CORRECTION			
TDUK-054/2	1	2 Degree Caster Correction Bush	
PANHARD RODS			
TDPR-004	1	Adjustable Panhard Rod	Suit RHD
TDPR-014	1	Adjustable Panhard Rod	Suit LHD
ADDITIONAL COMPONENTS			
TDUK-041	1	Front Radius Rod To Chassis	1 Kit Required Per Vehicle
TDUK-050	1	Front Radius Rod To Diff	1 Kit Required Per Vehicle
TDUK-051	1	Panhard Rod Bush Kit	1 Kit Required Per Panhard Rod
TDUK-1734/15	1	Urethane Spring Spacer 15mm	1 Required Per Coil As Required
TDUK-1734/30	1	Urethane Spring Spacer 30mm	1 Required Per Coil As Required
NAK-005	1	Offset Kinpin	0.5 Degree
NAK-075	1	Offset Kingpin	0.75 Degree
NAK-001	1	Offset Kingpin	1.0 Degree

Fitting sheet (located page 243) must be completed when suspension fitted. Failure to comply may affect warranty.



REAR SUSPENSION

ESTIMATED LIFT: 50mm

PART NO.	Qty	DESCRIPTION	NOTES
SHOCK ABSORBERS			
FC41206	2	Foam Cell Shock	Suit Up To 50mm Lift
BM401206	2	40mm 9 Stage Adjustable Shock	Suit Up To 50mm Lift
BMX1206/2	2	45mm 9 Stage Adjustable Shock	Suit 50mm Lift ONLY
TDR1206	2	'Ralph' Shock	Suit Up To 50mm Lift
COIL SPRINGS			
TDC733	1	0-300KG Load - 25mm Lift (Pair)	Suit SWB
TDC732SL	1	0-300KG Load - 25mm Lift (Pair)	Suit LWB
TDC732HSL	1	CONSTANT 300KG Load - 25mm Lift (Pair)	Suit LWB
TDC732CL	1	No Load (Comfort) - 50mm Lift (Pair)	Suit LWB
TDC732L	1	0-300KG Load - 50mm Lift (Pair)	Suit LWB
TDC749HL	1	CONSTANT 300KG Load - 50mm Lift (Pair)	Suit LWB
PANHARD RODS			
TDPR-005	1	Adjustable Panhard Rod	
ADDITIONAL COMPONENTS			
TDUK-052	1	Trailing Arm Bushing Kit	2 Kits Required Upper & Lower
TDUK-051	1	Panhard Rod Bushing Kit	1 Kit Required per Panhard Rod
TDUK-1736/15	1	Urethane Spring Spacer 15mm	1 Required Per Coil As Required
TDUK-1736/30	1	Urethane Spring Spacer 30mm	1 Required Per Coil As Required
AIR ASSIST BAGS			
TDAA-008	1	Coil Insert Bag Kit	Suit 50mm Lift
TDAA-017	1	Coil Insert Bag Kit	Suit Standard Height ONLY

REPLACEMENT BUSHINGS

PART NO.	Qty	DESCRIPTION	NOTES
QUANTITY PER SHOCK			
TW967	4	Suit Front Top & Bottom Pin	Pin Style Bushing
ADJ00191	1	Suit Rear Top Eying	Eying Bushing
415024	1	Suit Rear Bottom Eying	Eying Bushing



FRONT SUSPENSION

ESTIMATED LIFT: 50mm

PART NO.	Qty	DESCRIPTION	NOTES
SHOCK ABSORBERS			
FC41047	2	Foam Cell Shock	Suit Up To 50mm Lift
BM401047	2	40mm 9 Stage Adjustable Shock	Suit Up To 50mm Lift
BMX1047/2	2	45mm 9 Stage Adjustable Shock	Suit 50mm Lift ONLY
TDR1047B	2	'Ralph' Shock	Suit Up To 50mm Lift
COIL SPRINGS			
TDC734SL	1	25mm Lift Coil (Pair)	Up To Bar
TDC734HSL	1	25mm Lift Coil (Pair)	Bar/Winch
TDC734L	1	50mm Lift Coil (Pair)	Up To Bar
TDC734HL	1	50mm Lift Coil (Pair)	Bar/Winch
STEERING DAMPERS			
EXT5000	1	Heavy Duty Replacement Damper	
SS5000-P/S	1	Return To Centre Damper	Suit 12/1997-2000 ONLY
SV5000	1	9 Stage Adjustable Damper	
EXT5617	1	Heavy Duty Replacement Damper	
SS5617-P/S	1	Return To Centre Damper	Suit 04/2000-2015 ONLY
SV5617	1	9 Stage Adjustable Damper	
CASTER CORRECTION			
TDUK-054/2	1	2 Degree Caster Correction Bush	
PANHARD RODS			
TDPR-004	1	Adjustable Panhard Rod	Suit All Ute & Wagon Pre 02/2000
TDPR-014	1	Adjustable Panhard Rod	Suit Ute LHD ONLY
TDPR-012	1	Adjustable Panhard Rod	Suit Wagon 02/2000 On
TDPR-016	1	Adjustable Panhard Rod	Suit Wagon LHD ONLY
ADDITIONAL COMPONENTS			
TDUK-041	1	Front Radius Rod To Chassis	1 Kit Required Per Vehicle
TDUK-050	1	Front Radius Rod To Diff	1 Kit Required Per Vehicle
TDUK-055	1	Panhard Rod Bush (Diff End)	1 Kit Required (Diff End ONLY)
TDUK-056	1	Panhard Rod Bush (Chassis End)	1 Kit Required (Chassis End ONLY)
TDUK-1734/15	1	Urethane Spring Spacer 15mm	1 Required Per Coil As Required
TDUK-1734/30	1	Urethane Spring Spacer 30mm	1 Required Per Coil As Required
NAK-005	1	Offset Kingpin	0.5 Degree
NAK-075	1	Offset Kingpin	0.75 Degree
NAK-001	1	Offset Kingpin	1.0 Degree

Fitting sheet (located page 243) must be completed when suspension fitted. Failure to comply may affect warranty.



REAR SUSPENSION

ESTIMATED LIFT: 50mm

PART NO.	Qty	DESCRIPTION	NOTES
SHOCK ABSORBERS			
FC41206	2	Foam Cell Shock	Suit Up To 50mm Lift
BM401206	2	40mm 9 Stage Adjustable Shock	Suit Up To 50mm Lift
BMX1206/2	2	45mm 9 Stage Adjustable Shock	Suit 50mm Lift ONLY
TDR1206	2	'Ralph' Shock	Suit Up To 50mm Lift
COIL SPRINGS			
TDC742SL	1	0-300KG Load (Pair)	25mm Lift
TDC742HSL	1	CONSTANT 300KG Load (Pair)	25mm Lift
TDC742L	1	0-300KG Load (Pair)	50mm Lift
TDC742HL	1	CONSTANT 300KG Load (Pair)	50mm Lift
PANHARD RODS			
TDPR-005	1	Adjustable Panhard Rod	Suit All Ute & Wagon Pre-02/2000
TDPR-013	1	Adjustable Panhard Rod	Suit Wagon 02/2000 On
ADDITIONAL COMPONENTS			
TDUK-052	1	Trailing Arm Bushing Kit	2 Kits Required Upper & Lower
TDUK-055	1	Panhard Rod Bush (Diff End)	1 Kit Required (Diff End ONLY)
TDUK-056	1	Panhard Rod Bush (Chassis End)	1 Kit Required (Chassis End ONLY)
TDUK-1736/15	1	Urethane Spring Spacer 15mm	1 Required Per Coil As Required
TDUK-1736/30	1	Urethane Spring Spacer 30mm	1 Required Per Coil As Required
AIR ASSIST BAGS			
TDAA-008	1	Coil Insert Bag Kit	Suit 50mm Lift
TDAA-017	1	Coil Insert Bag Kit	Suit OE Height ONLY

REPLACEMENT BUSHINGS

PART NO.	Qty	DESCRIPTION	NOTES
QUANTITY PER SHOCK			
TW967	4	Suit Front Top & Bottom Pin	Pin Style Bushing
ADJ00191	1	Suit Rear Top Eying	Eying Bushing
415024	1	Suit Rear Bottom Eying	Eying Bushing



FRONT SUSPENSION

ESTIMATED LIFT: 75mm

PART NO.	Qty	DESCRIPTION	NOTES
SHOCK ABSORBERS			
FC41047/3	2	Foam Cell Shock	Suit 75mm Lift
BM401047/3	2	40mm 9 Stage Adjustable Shock	Suit 75mm Lift
BMX1047/3	2	45mm 9 Stage Adjustable Shock	Suit 75mm Lift
COIL SPRINGS			
TDC734/3	1	75mm Lift Coil (Pair)	Up To Bar
TDC734/3H	1	75mm Lift Coil (Pair)	Bar/Winch
STEERING DAMPERS			
EXT5612	1	Heavy Duty Replacement Damper	
SS5612-P/S	1	Return To Centre Damper	Suit 02/1988-1989 GQ ONLY
SV5612	1	9 Stage Adjustable Damper	
EXT5613	1	Heavy Duty Replacement Damper	
SS5613-P/S	1	Return To Centre Damper	Suit 08/1989-1998 GQ ONLY
SV5613	1	9 Stage Adjustable Damper	
EXT5000	1	Heavy Duty Replacement Damper	
SS5000-P/S	1	Return To Centre Damper	Suit 12/1997-2000 GU ONLY
SV5000	1	9 Stage Adjustable Damper	
EXT5617	1	Heavy Duty Replacement Damper	
SS5617-P/S	1	Return To Centre Damper	Suit 04/2000-2015 GU ONLY
SV5617	1	9 Stage Adjustable Damper	
CASTER CORRECTION			
TDUK-054/2	1	2 Degree Caster Correction Bush	
PANHARD RODS			
TDPR-004	1	Adjustable Panhard Rod	Suits All GQ & GU Ute & Wagon Pre 02/2000
TDPR-014	1	Adjustable Panhard Rod	Suit GQ (All & GU Ute) LHD
TDPR-012	1	Adjustable Panhard Rod	Suit GU Wagon 02/2000 On
TDPR-016	1	Adjustable Panhard Rod	Suit GU Wagon LHD ONLY
ADDITIONAL COMPONENTS			
TDUK-041	1	Front Radius Rod To Chassis	1 Kit Required Per Vehicle
TDUK-050	1	Front Radius Rod To Diff	1 Kit Required Per Vehicle
TDUK-051	1	Panhard Rod Bush Kit	Suit TDPR-004 & 014 ONLY
TDUK-055	1	Panhard Rod Bush (Diff End)	Suit TDPR-012, 013 & 016 (Diff End)
TDUK-056	1	Panhard Rod Bush (Chassis End)	Suit TDPR-012, 013 & 016 (Chassis End)
NAK-005	1	Offset Kingpin	0.5 Degree
NAK-075	1	Offset Kingpin	0.75 Degree
NAK-001	1	Offset Kingpin	1.0 Degree

Fitting sheet (located page 243) must be completed when suspension fitted. Failure to comply may affect warranty.



REAR SUSPENSION

ESTIMATED LIFT: 75mm

PART NO.	Qty	DESCRIPTION	NOTES
SHOCK ABSORBERS			
FC41206/3	2	Foam Cell Shock	Suit 75mm Lift
BM401206/3	2	40mm 9 Stage Adjustable Shock	Suit 75mm Lift
BMX1206/3	2	45mm 9 Stage Adjustable Shock	Suit 75mm Lift
COIL SPRINGS			
TDC732/3	1	0-300KG Load - 75mm Lift (Pair)	75mm Lift
TDC732/3H	1	CONSTANT 300KG Load (Pair)	75mm Lift
PANHARD RODS			
TDPR-005	1	Adjustable Panhard Rod	Suit GQ (All & GU Ute) & Wagon Pre 02/2000
TDPR-013	1	Adjustable Panhard Rod	Suit GU Wagon 02/2000 On
ADDITIONAL COMPONENTS			
TDUK-051	1	Panhard Rod Bush Kit	Suit TDPR-005 ONLY
TDUK-052	1	Trailing Arm Bushing Kit	2 Kits Required - Upper & Lower
TDUK-055	1	Panhard Rod Bush (Diff End)	1 Kit Required (Diff End ONLY)
TDUK-056	1	Panhard Rod Bush (Chassis End)	1 Kit Required (Chassis End ONLY)
TRANSMISSION SPACER			
TDSP-004/2	1	Transmission Spacer Kit	
BRAKE HOSE KITS			
TDBH-001	1	Non ABS Rubber Hose	Suit Up To 2002
TDBH-194	1	Non ABS Braided Hose	
TDBH-390	1	ABS Rubber Hose	
TDBH-190	1	ABS Braided Hose	Suit 1998 On
TDBH-400	1	ABS & Stability Rubber Hose	

COMPLETE KIT PRICE REFERENCE

SHOCK CHOICE	SPRING CHOICE	CONTENTS
41mm Foam Cell	All GQ & GU Utes and Wagons Pre 02/2000	 <p>Includes: 4 x Coil Springs 4 x Shocks 1 x Caster Correction Kit 2 x Panhard Rods 1 x Transmission Spacer 1 x Brake Hose Kit (Brake Hose kit is rubber non ABS - adjust price if required)</p>
	All GQ & GU Utes and Wagons Post 02/2000	
40mm 9 Stage Adjustable	All GQ & GU Utes and Wagons Pre 02/2000	
	All GQ & GU Utes and Wagons Post 02/2000	
45mm 9 Stage Adjustable	All GQ & GU Utes and Wagons Pre 02/2000	
	All GQ & GU Utes and Wagons Post 02/2000	



FRONT SUSPENSION

ESTIMATED LIFT: 100mm

PART NO.	Qty	DESCRIPTION	NOTES
SHOCK ABSORBERS			
FC41047/4	2	Foam Cell Shock	Suit 100mm Lift
BMX1047/4/5	2	45mm Adjustable Shock	Suit 100mm Lift
COIL SPRINGS			
TDC734/4	1	100mm Lift Coil (Pair)	Bar
TDC734/4H	1	100mm Lift Coil (Pair)	Bar/Winch
STEERING DAMPERS			
SS5613-XHD	1	H/Duty Return To Centre Damper	Comes with Brackets
SV5613/4	1	9 Stage Adjustable Damper	
CASTER CORRECTION			
TDUK-054/3	1	3 Degree Caster Correction Bush	
PANHARD RODS			
TDPR-004	1	Adjustable Panhard Rod	Suits All GQ & GU Ute & Wagon Pre 02/2000
TDPR-014	1	Adjustable Panhard Rod	Suit GQ (All) & GU Ute LHD
TDPR-012	1	Adjustable Panhard Rod	Suit GU Wagon 02/2000 On
TDPR-016	1	Adjustable Panhard Rod	Suit GU Wagon LHD ONLY
ADDITIONAL COMPONENTS			
TDUK-041	1	Front Radius Rod to Chassis	1 Kit Required Per Vehicle
TDUK-050	1	Front Radius Rod To Diff	1 Kit Required Per Vehicle
TDUK-051	1	Panhard Rod Bush Kit	Suit TDPR-004 & 014 ONLY
TDUK-055	1	Panhard Rod Bush (Diff End)	Suit TDPR-012, 013 & 016 (Diff End)
TDUK-056	1	Panhard Rod Bush (Chassis End)	Suit TDPR-012, 013 & 016 (Chassis End)
NAK-005	1	Offset Kingpin	0.5 Degree
NAK-075	1	Offset Kingpin	0.75 Degree
NAK-001	1	Offset Kingpin	1.0 Degree

PLEASE NOTE:

Vehicles lifted 100mm or more require the rear tailshaft to be spun 180 Degrees so that the clearance between the cross member and the tailshaft is increased.

REPLACEMENT BUSHINGS - Refer page 143

Please select components needed as outlined in the table at right

Fitting sheet (located page 243) must be completed when suspension fitted. Failure to comply may affect warranty.



REAR SUSPENSION

ESTIMATED LIFT: 100mm

PART NO.	Qty	DESCRIPTION	NOTES
SHOCK ABSORBERS			
FC41206/4	2	Foam Cell Shock	Suit 100mm Lift
BMX1206/4/5	2	45mm Adjustable Shock	Suit 100mm Lift
COIL SPRINGS			
TDC732/4	1	0-300KG Load (Pair)	Suit 100mm Lift
TDC732/4H	1	CONSTANT 300KG Load (Pair)	Suit 100mm Lift
PANHARD RODS			
TDPR-005	1	Adjustable Panhard Rod	Suit GQ (All & GU Ute) Pre 02/2000
TDPR-013	1	Adjustable Panhard Rod	Suit GU Wagon 02/2000 On
ADDITIONAL COMPONENTS			
TDUK-051	1	Panhard Rod Bushes	Suit TDPR-005 ONLY
TDUK-052	1	Trailing Arm Bushing Kit	2 Kits Required Upper & Lower
TDUK-055	1	Panhard Rod Bush (Diff End)	1 Kit Required (Diff End ONLY)
TDUK-056	1	Panhard Rod Bush (Chassis End)	1 Kit Required (Chassis End ONLY)
TRANSMISSION SPACER			
TDSP-004/2	1	Transmission Spacer Kit	
BRAKE HOSE KITS			
TDBH-001	1	Non ABS Rubber Hose	Suit Up To 2002
TDBH-194	1	Non ABS Braided Hose	
TDBH-390	1	ABS Rubber Hose	
TDBH-190	1	ABS Braided Hose	Suit 1998 On
TDBH-400	1	ABS & Stability Rubber Hose	

COMPLETE KIT PRICE REFERENCE

SHOCK CHOICE	SPRING CHOICE	CONTENTS
41mm Foam Cell	All GQ & GU Utes and Wagons Pre 02/2000	 <p>Includes: 4 x Coil Springs 4 x Shocks 1 x Caster Correction Kit 2 x Panhard Rods 1 x Transmission Spacer 1 x Brake Hose Kit (Brake Hose kit is rubber non ABS - adjust price if required)</p>
	All GQ & GU Utes and Wagons Post 02/2000	
45mm 9 Stage Adjustable	All GQ & GU Utes and Wagons Pre 02/2000	
	All GQ & GU Utes and Wagons Post 02/2000	



FRONT SUSPENSION

ESTIMATED LIFT: 125mm

PART NO.	Qty	DESCRIPTION	NOTES
SHOCK ABSORBERS			
BMX1047/4/5	2	45mm Adjustable Shock	Suit 125mm Lift ONLY
COIL SPRINGS			
TDC734/5	1	125mm Lift Coil (Pair)	Bar
TDC734/5H	1	125mm Lift Coil (Pair)	Bar/Winch
STEERING DAMPERS			
SS5613-XHD	1	H/Duty Return To Centre Damper	Comes With Brackets
SV5613/4	1	9 Stage Adjustable Damper	
CASTER CORRECTION			
TDCP-005	1	5 Degree Caster Correction Plate	
PANHARD RODS			
TDPR-004	1	Adjustable Panhard Rod	Suits All GQ & GU Ute & Wagon Pre 02/2000
TDPR-014	1	Adjustable Panhard Rod	Suit GQ (All) & GU Ute LHD
TDPR-012	1	Adjustable Panhard Rod	Suit GU Wagon 02/2000 On
TDPR-016	1	Adjustable Panhard Rod	Suit GU Wagon LHD ONLY
ADDITIONAL COMPONENTS			
TDUK-041	1	Front Radius Rod to Chassis	1 Kit Required Per Vehicle
TDUK-050	1	Front Radius Rod To Diff	1 Kit Required Per Vehicle
TDUK-051	1	Panhard Rod Bush Kit	Suit TDPR-004 & 014 ONLY
TDUK-055	1	Panhard Rod Bush (Diff End)	Suit TDPR-012, 013 & 016 (Diff End)
TDUK-056	1	Panhard Rod Bush (Chassis End)	Suit TDPR-012, 013 & 016 (Chassis End)
NAK-005	1	Offset Kingpin	0.5 Degree
NAK-075	1	Offset Kingpin	0.75 Degree
NAK-001	1	Offset Kingpin	1.0 Degree

PLEASE NOTE:

Vehicles lifted 100mm or more require the rear tailshaft to be spun 180 Degrees so that the clearance between the cross member and the tailshaft is increased.

REPLACEMENT BUSHINGS - Refer page 143

Please select components needed as outlined in the table at right

Fitting sheet (located page 243) must be completed when suspension fitted. Failure to comply may affect warranty.



REAR SUSPENSION

ESTIMATED LIFT: 125mm

PART NO.	Qty	DESCRIPTION	NOTES
SHOCK ABSORBERS			
BMX1206/4/5	2	45mm Adjustable Shock	Suit 125mm Lift ONLY
COIL SPRINGS			
TDC732/5	1	0-300KG Load (Pair)	125mm Lift
TDC732/5H	1	CONSTANT 300KG Load (Pair)	125mm Lift
PANHARD RODS			
TDPR-005	1	Adjustable Panhard Rod	Suit GQ (All & GU Ute) & Wagon Pre 02/2000
TDPR-013	1	Adjustable Panhard Rod	Suit GU Wagon 02/2000 On
ADDITIONAL COMPONENTS			
TDUK-051	1	Panhard Rod Bushes	Suit TDPR-005 ONLY
TDUK-052	1	Trailing Arm Bushing Kit	2 Kits Required Upper & Lower
TDUK-055	1	Panhard Rod Bush (Diff End)	1 Kit Required (Diff End ONLY)
TDUK-056	1	Panhard Rod Bush (Chassis End)	1 Kit Required (Chassis End ONLY)
TRANSMISSION SPACER			
TDSP-004/2	1	Transmission Spacer Kit	
BRAKE HOSE KITS			
TDBH-001	1	Non ABS Rubber Hose	Suit Up To 2002
TDBH-194	1	Non ABS Braided Hose	
TDBH-390	1	ABS Rubber Hose	
TDBH-190	1	ABS Braided Hose	Suit 1998 On
TDBH-400	1	ABS & Stability Rubber Hose	

COMPLETE KIT PRICE REFERENCE

SHOCK CHOICE	SPRING CHOICE	CONTENTS
45mm 9 Stage Adjustable To Suit all GQ & GU Utes & Wagons Pre 02-2000	0-300KG	 <p>Includes: 4 x Coil Springs 4 x Shocks 1 x Caster Correction Kit 2 x Panhard Rods 1 x Transmission Spacer 1 x Brake Hose Kit (Brake Hose kit is rubber non ABS - adjust price if required)</p>
	300KG Constant	
45mm 9 Stage Adjustable To Suit GU Wagons Post 02-2000	0-300KG	
	300KG Constant	



FRONT SUSPENSION

ESTIMATED LIFT: 150mm

PART NO.	Qty	DESCRIPTION	NOTES
SHOCK ABSORBERS			
BMX1047/6	2	45mm Adjustable Shock	Suit 150mm Lift ONLY
COIL SPRINGS			
TDC734/6	1	125mm Lift Coil (Pair)	Bar
TDC734/6H	1	125mm Lift Coil (Pair)	Bar/Winch
STEERING DAMPERS			
SS5613-XHD	1	H/Duty Return To Centre Damper	Comes With Brackets
SV5613/4	1	9 Stage Adjustable Damper	
CASTER CORRECTION			
TDCP-007	1	7 Degree Caster Correction Plate	
PANHARD RODS			
TDPR-004	1	Adjustable Panhard Rod	Suits All GQ & GU Ute & Wagon Pre 02/2000
TDPR-014	1	Adjustable Panhard Rod	Suit GQ (All) & GU Ute LHD
TDPR-012	1	Adjustable Panhard Rod	Suit GU Wagon 02/2000 On
TDPR-016	1	Adjustable Panhard Rod	Suit GU Wagon LHD ONLY
ADDITIONAL COMPONENTS			
TDUK-041	1	Front Radius Rod to Chassis	1 Kit Required Per Vehicle
TDUK-050	1	Front Radius Rod To Diff	1 Kit Required Per Vehicle
TDUK-051	1	Panhard Rod Bush Kit	Suit TDPR-004 & 014 ONLY
TDUK-055	1	Panhard Rod Bush (Diff End)	Suit TDPR-012, 013 & 016 (Diff End)
TDUK-056	1	Panhard Rod Bush (Chassis End)	Suit TDPR-012, 013 & 016 (Chassis End)
NAK-005	1	Offset Kingpin	0.5 Degree
NAK-075	1	Offset Kingpin	0.75 Degree
NAK-001	1	Offset Kingpin	1.0 Degree

PLEASE NOTE:

Vehicles lifted 100mm or more require the rear tailshaft to be spun 180 Degrees so that the clearance between the cross member and the tailshaft is increased.

REPLACEMENT BUSHINGS - Refer page 143

Please select components needed as outlined in the table at right

Fitting sheet (located page 243) must be completed when suspension fitted. Failure to comply may affect warranty.



REAR SUSPENSION

ESTIMATED LIFT: 150mm

PART NO.	Qty	DESCRIPTION	NOTES
SHOCK ABSORBERS			
BMX1206/6	2	45mm Adjustable Shock	Suit 150mm Lift ONLY
COIL SPRINGS			
TDC732/6	1	0-300KG Load (Pair)	150mm Lift
TDC732/6H	1	CONSTANT 300KG Load (Pair)	150mm Lift
PANHARD RODS			
TDPR-005	1	Adjustable Panhard Rod	Suit GQ (All & GU Ute) & Wagon Pre 02/2000
TDPR-013	1	Adjustable Panhard Rod	Suit GU Wagon 02/2000 On
ADDITIONAL COMPONENTS			
TDUK-051	1	Panhard Rod Bushes	Suit TDPR-005 ONLY
TDUK-052	1	Trailing Arm Bushing Kit	2 Kits Required Upper & Lower
TDUK-055	1	Panhard Rod Bush (Diff End)	1 Kit Required (Diff End ONLY)
TDUK-056	1	Panhard Rod Bush (Chassis End)	1 Kit Required (Chassis End ONLY)
TRANSMISSION SPACER			
TDSP-004/2	1	Transmission Spacer Kit	
BRAKE HOSE KITS			
TDBH-001	1	Non ABS Rubber Hose	Suit Up To 2002
TDBH-194	1	Non ABS Braided Hose	
TDBH-390	1	ABS Rubber Hose	Suit 1998 On
TDBH-190	1	ABS Braided Hose	
TDBH-400	1	ABS & Stability Rubber Hose	

COMPLETE KIT PRICE REFERENCE

SHOCK CHOICE	SPRING CHOICE	CONTENTS
45mm 9 Stage Adjustable To Suit all GQ & GU Utes & Wagons Pre 02-2000	Up to Bar	<p>Includes: 4 x Coil Springs 4 x Shocks 1 x Caster Correction Kit 2 x Panhard Rods 1 x Transmission Spacer 1 x Brake Hose Kit (Brake Hose kit is rubber non ABS - adjust price if required)</p>
	Bar & Winch	
45mm 9 Stage Adjustable To Suit GU Wagons Post 02-2000	Up to Bar	
	Bar & Winch	



FRONT SUSPENSION

ESTIMATED LIFT: 50mm

PART NO.	Qty	DESCRIPTION	NOTES
SHOCK ABSORBERS			
FC41108	2	Foam Cell Shock	Suit OE Height
BM401108	2	40mm Adjustable Shock	
FC41113	2	Foam Cell Shock	Suit 50mm Lift
BM401113	2	Adjustable Shock	
LEAF SPRINGS			
1 Left Hand Side and 1 Right Hand Side leaf spring pack should be ordered			
FS37-LH	1	50mm Lift Spring	Bar Left Hand Side
FS37-RH	1	50mm Lift Spring	Bar Right Hand Side
FS37H-LH	1	50mm Lift Spring	Bar/Winch Left Hand Side
FS37H-RH	1	50mm Lift Spring	Bar/Winch Right Hand Side
STEERING DAMPERS			
EXT5005	1	Heavy Duty Replacement Damper	Eye/Eye Mounting
SS5005-P/S	1	Return To Centre Damper	
EXT5613	1	Heavy Duty Replacement Damper	Pin/Pin Mounting
SS5613-P/S	1	Return To Centre Damper	
SV5613	1	9 Stage Adjustable Damper	
ADDITIONAL COMPONENTS			
TDUK-011	1	Urethane Shackle Bushing Kit	
TDUB-011	2	U-Bolt Kit	
TDGP-667	1	Greasable Pin Kit	
TDGS-357	1	Greasable Shackle Kit	
NAK-005	1	Offset Kingpin	0.5 Degree
NAK-075	1	Offset Kingpin	0.75 Degree
NAK-001	1	Offset Kingpin	1.0 Degree

Fitting sheet (located page 243) must be completed when suspension fitted. Failure to comply may affect warranty.



REAR SUSPENSION

ESTIMATED LIFT: 50mm

PART NO.	Qty	DESCRIPTION	NOTES
SHOCK ABSORBERS			
FC41404	2	Foam Cell Shock	Suit 50mm Lift
BM401404	2	40mm Adjustable Shock	Suit 50mm Lift
LEAF SPRINGS			
Where stated 1 Left Hand Side and 1 Right Hand Side leaf pack should be ordered			
BPN-010	2	0-300KG Load	50mm Lift Spring
BPN-010H	2	CONSTANT 300KG Load	50mm Lift Spring
FS39M-LH	1	CONSTANT 500KG Load	50mm Lift Spring Left Hand Side
FS39M-RH	1	CONSTANT 500KG Load	50mm Lift Spring Right Hand Side
FS38M-LH	1	CONSTANT GVM - Mine Spec	50mm Lift Spring Left Hand Side
FS38M-RH	1	CONSTANT GVM - Mine Spec	50mm Lift Spring Right Hand Side
ADDITIONAL COMPONENTS			
TDUK-012	1	Urethane Shackle Bushing Kit	
TDUB-025	2	U-Bolt	
TDGP-667	1	Greasable Pin Kit	
TDGS-357	1	Greasable Shackle Kit	
AIR ASSIST BAGS			
TDAA-110	1	Bellows Bag Kit	Suit 50mm Lift

REPLACEMENT BUSHINGS

PART NO.	Qty	DESCRIPTION	NOTES
QUANTITY PER SHOCK			
TW959	2	Suit Front Top Pin	Pin Style Bushing
ADJ00191	1	Suit Front Bottom Eying	Eying Bushing
ADJ00191	1	Suit Rear Top Eying	Eying Bushing
TW959	2	Suit Rear Bottom Pin	Pin Style Bushing



FRONT SUSPENSION

ESTIMATED LIFT: 50mm

PART NO.	Qty	DESCRIPTION	NOTES
SHOCK ABSORBERS			
FC41047	2	Foam Cell Shock	Suit Up To 50mm Lift
BM401047	2	40mm 9 Stage Adjustable Shock	Suit Up To 50mm Lift
BMX1047/2	2	45mm 9 Stage Adjustable Shock	Suit 50mm Lift ONLY
TDR1047B	2	'Ralph' Shock	Suit Up To 50mm Lift
COIL SPRINGS			
TDC734L	1	50mm Lift Coil (Pair)	Bar
TDC734HL	1	50mm Lift Coil (Pair)	Bar/Winch
STEERING DAMPERS			
EXT5613	1	Heavy Duty Replacement Damper	
SS5613-P/S	1	Return To Centre Damper	GQ (Pin/Pin) ONLY
SV5613	1	9 Stage Adjustable Damper	
EXT5000	1	Heavy Duty Replacment Damper	
SS5000-P/S	1	Return To Centre Damper	GU (Pin/Pin) ONLY
SV5000	1	9 Stage Adjustable Damper	
CASTER CORRECTION			
TDUK-054/2	1	2 Degree Caster Correction Bush	1 Kit Required Per Vehicle
PANHARD RODS			
TDPR-004	1	Adjustable Panhard Rod	Suit RHD
TDPR-014	1	Adjustable Panhard Rod	Suit LHD ONLY
ADDITIONAL COMPONENTS			
TDUK-041	1	Front Radius Rod to Chassis	1 Kit Required Per Vehicle
TDUK-050	1	Front Radius Rod To Diff	1 Kit Required Per Vehicle
TDUK-051	1	Panhard Rod Bush Kit	1 Kit Required Per Panhard Rod
TDUK-1734/15	1	Urethane Spring Spacer 15mm	1 Kit Required Per Coil As Required
TDUK-1734/30	1	Urethane Spring Spacer 30mm	1 Kit Required Per Coil As Required
NAK-005	1	Offset Kingpin	0.5 Degree
NAK-075	1	Offset Kingpin	0.75 Degree
NAK-001	1	Offset Kingpin	1.0 Degree

REPLACEMENT BUSHINGS

PART NO.	Qty	DESCRIPTION	NOTES
QUANTITY PER SHOCK			
TW967	4	Suit Front Top & Bottom Pin	Pin Style Bushing
ADJ00191	1	Suit Rear Top Eying	Eying Bushing
415024	1	Suit Rear Bottom Pin	Pin Style Bushing

Fitting sheet (located page 243) must be completed when suspension fitted. Failure to comply may affect warranty.



NISSAN

PATROL - GQ/GU CAB CHASSIS (COIL/LEAF) 1997 - 2016



REAR SUSPENSION

ESTIMATED LIFT: 50mm

PART NO.	Qty	DESCRIPTION	NOTES
SHOCK ABSORBERS			
FC41404	2	Foam Cell Shock	Suit Up To 50mm Lift
BM401404	2	40mm 9 Stage Adjustable Shock	Suit Up To 50mm Lift
BMX1404/2	2	45mm 9 Stage Adjustable Shock	Suit 50mm Lift ONLY
TDR1404	2	'Ralph' Shock	Suit Up To 50mm Lift
LEAF SPRINGS			
Where stated 1 Left Hand Side and 1 Right Hand Side leaf pack should be ordered			
BPN-010	2	0-300KG Load	50mm Lift Spring
BPN-010H	2	CONSTANT 300KG Load	50mm Lift Spring
FS39M-LH	1	CONSTANT 500KG Load	50mm Lift Spring Left Hand Side
FS39M-RH	1	CONSTANT 500KG Load	50mm Lift Spring Right Hand Side
FS38M-LH	1	CONSTANT GVM - Mine Spec	50mm Lift Spring Left Hand Side
FS38M-RH	1	CONSTANT GVM - Mine Spec	50mm Lift Spring Right Hand Side
ADDITIONAL COMPONENTS			
TDUK-012	1	Urethane Shackle Bushing Kit	
TDUB-023	2	U-Bolt Kit	
TDGP-667	1	Greasable Pin Kit	
TDGS-357	1	Greasable Shackle Kit	
AIR ASSIST BAGS			
TDAA-111	1	Bellows Bag Kit	Suit 50mm Lift

All prices exclude freight. Include only permanent accessories & weights when selecting springs. Towing weight is not included.



FRONT SUSPENSION

ESTIMATED LIFT: 50mm

PART NO.	Qty	DESCRIPTION	NOTES
SHOCK ABSORBERS			
FC41047	2	Foam Cell Shock	Suit Up To 50mm Lift
BM401047	2	40mm 9 Stage Adjustable Shock	Suit Up To 50mm Lift
BMX1047/2	2	45mm 9 Stage Adjustable Shock	Suit 50mm Lift ONLY
TDR1047B	2	'Ralph' Shock	Suit Up To 50mm Lift
COIL SPRINGS			
TDC734L	1	50mm Lift Coil (Pair)	Bar
TDC734HL	1	50mm Lift Coil (Pair)	Bar/Winch
STEERING DAMPERS			
EXT5613	1	Heavy Duty Replacement Damper	
SS5613-P/S	1	Return To Centre Damper	GQ (Pin/Pin) ONLY
SV5613	1	9 Stage Adjustable Damper	
EXT5000	1	Heavy Duty Replacement Damper	
SS5000-P/S	1	Return To Centre Damper	GU (Pin/Pin) ONLY
SV5000	1	9 Stage Adjustable Damper	
CASTER CORRECTION			
TDUK-054/2	1	2 Degree Caster Correction Bush	1 Kit Required Per Vehicle
PANHARD RODS			
TDPR-004	1	Adjustable Panhard Rod	
ADDITIONAL COMPONENTS			
TDUK-041	1	Front Radius Rod to Chassis	1 Kit Required Per Vehicle
TDUK-050	1	Front Radius Rod To Diff	1 Kit Required Per Vehicle
TDUK-051	1	Panhard Rod Bush Kit	1 Kit Required Per Panhard Rod
TDUK-1734/15	1	Urethane Spring Spacer 15mm	1 Kit Required Per Coil As Required
TDUK-1734/30	1	Urethane Spring Spacer 30mm	1 Kit Required Per Coil As Required
NAK-005	1	Offset Kingpin	0.5 Degree
NAK-075	1	Offset Kingpin	0.75 Degree
NAK-001	1	Offset Kingpin	1.0 Degree

Fitting sheet (located page 243) must be completed when suspension fitted. Failure to comply may affect warranty.



REAR SUSPENSION

ESTIMATED LIFT: 50mm

PART NO.	Qty	DESCRIPTION	NOTES
SHOCK ABSORBERS			
FC41206	2	Foam Cell Shock	Suit Up To 50mm Lift
BM401206	2	40mm 9 Stage Adjustable Shock	Suit Up To 50mm Lift
BMX1206/2	2	45mm 9 Stage Adjustable Shock	Suit 50mm Lift ONLY
TDR1206	2	'Ralph' Shock	Suit Up To 50mm Lift
COIL SPRINGS			
TDC749HL	1	0-300KG Load (Pair)	50mm Lift
TDC749VHL	1	CONSTANT 300KG Load (Pair)	50mm Lift
PANHARD RODS			
TDPR-005	1	Adjustable Panhard Rod	
ADDITIONAL COMPONENTS			
TDUK-051	1	Panhard Rod Bushes	Suit TDPR-005 ONLY
TDUK-052	1	Trailing Arm Bushing Kit	2 Kits Required Upper & Lower
TDUK-1736/15	1	Urethane Spring Spacer 15mm	1 Kit Required Per Coil As Required
TDUK-1736/30	1	Urethane Spring Spacer 30mm	1 Kit Required Per Coil As Required

REPLACEMENT BUSHINGS

PART NO.	Qty	DESCRIPTION	NOTES
QUANTITY PER SHOCK			
TW967	4	Suit Front Top & Bottom Pin	Pin Style Bushing
ADJ00191	1	Suit Rear Top Eying	Eying Bushing
415024	1	Suit Rear Bottom Eying	Eying Bushing



FRONT SUSPENSION

ESTIMATED LIFT: 40mm

PART NO.	Qty	DESCRIPTION	NOTES
SHOCK ABSORBERS			
FC404750	2	Foam Cell Strut	
BM404750	2	40mm Adjustable Strut	9 Stage Adjustable
BMX454750	2	45mm Adjustable Strut	9 Stage Adjustable
COIL SPRINGS			
TDC790L	1	40mm Lift Spring (Pair)	Petrol/Bar
TDC790HL	1	40mm Lift Spring (Pair)	Petrol/Bar/Winch
TDC791L	1	40mm Lift Spring - BMX ONLY (Pair)	Petrol/Bar
TDC791HL	1	40mm Lift Spring - BMX ONLY (Pair)	Petrol/Bar/Winch
COMPLETE STRUT ASSEMBLY			
NIS-062/02	2	FC404750/TDC790L	Petrol/Bar
NIS-062/03	2	FC404750/TDC790HL	Petrol/Bar/Winch
NIS-062/07	2	BM404750/TDC790L	Petrol/Bar
NIS-062/08	2	BM404750/TDC790HL	Petrol/Bar/Winch
NIS-062/10	2	BMX454750/TDC791L	Petrol/Bar - BMX ONLY
NIS-062/11	2	BMX454750/TDC791HL	Petrol/Bar/Winch - BMX ONLY
ADDITIONAL COMPONENTS			
NIS-062	2	Strut Top	Replacement Strut Top

REPLACEMENT BUSHINGS

PART NO.	Qty	DESCRIPTION	NOTES
QUANTITY PER SHOCK			
4WAY-002	1	Suit Front Bottom Eying	Eying Bonded Bushing
Retainer W + X	1	Suit Rear Top Pin	1 Each Required Upper & Lower
ADJ27805	1	Suit Rear Bottom Eying	Eying Bonded Bushing

Fitting sheet (located page 243) must be completed when suspension fitted. Failure to comply may affect warranty.



NISSAN

PATROL - Y62 (NON HYDRAULIC ONLY) 2013 ON



REAR SUSPENSION

ESTIMATED LIFT: 40mm

PART NO.	Qty	DESCRIPTION	NOTES
SHOCK ABSORBERS			
FC41220	2	Foam Cell Shock	Up To 40mm Lift
BM401220	2	40mm 9 Stage Adjustable	Up To 40mm Lift
BMX1220/2	2	45mm 9 Stage Adjustable	UP To 40mm Lift
COIL SPRINGS			
TDC795	1	0-120KG Load (Pair)	40mm Lift
TDC795L	1	CONSTANT 120-300KG Load (Pair)	40mm Lift
TDC795HL	1	CONSTANT 300KG Load (Pair)	40mm Lift
AIR ASSIST BAGS			
TDAA-022	1	Coil Insert Bag Kit	Suit Standard Height ONLY
TDAA-023	1	Coil Insert Bag Kit	Suit 40mm Lift

All prices exclude freight. Include only permanent accessories & weights when selecting springs. Towing weight is not included.





FRONT SUSPENSION

ESTIMATED LIFT: 30mm

PART NO.	Qty	DESCRIPTION	NOTES
SHOCK ABSORBERS			
BD2057T	2	Nitrogen Gas Shock	Up To 30mm Lift
FC42057B	2	Foam Cell Shock	Up To 30mm Lift
TORSION BARS			
4WTB-1458	1	Replacement Torsion Bars	26mm/1232mm
Adjust Torsion bars after fitting shocks - Ensure a minimum of 60mm droop is maintained			

REAR SUSPENSION

PART NO.	Qty	DESCRIPTION	NOTES
SHOCK ABSORBERS			
BD1388T	2	Nitrogen Gas Shock	Up To 30mm Lift
FC41388	2	Foam Cell Shock	Up To 30mm Lift
BM401388	2	40mm 9 Stage Adjustable Shock	Up To 30mm Lift
COIL SPRINGS			
TDC739	1	0-300KG Load (Pair)	30mm Lift
TDC739H	1	CONSTANT 300KG Load (Pair)	30mm Lift

REPLACEMENT BUSHINGS

PART NO.	Qty	DESCRIPTION	NOTES
QUANTITY PER SHOCK			
TW959	2	Suit Front Top Pin Mount	Pin Style Bushing
412772	1	Suit Front Bottom Eying	Eying Bushing
404702	2	Suit Rear Top & Bottom Eying	Eying Bushing

Fitting sheet (located page 243) must be completed when suspension fitted. Failure to comply may affect warranty.



FRONT SUSPENSION

ESTIMATED LIFT: 50mm

PART NO.	Qty	DESCRIPTION	NOTES
SHOCK ABSORBERS			
FC404927	2	Foam Cell Shock	
BM404927	2	40mm Adjustable Shock	9 Stage Adjustable
COIL SPRINGS			
TDC1024	1	50mm Lift Spring (Pair)	No Accessories
TDC1025	1	50mm Lift Spring (Pair)	Suits Up To Bar and Winch
COMPLETE STRUT ASSEMBLY			
1 Left Hand Side and 1 Right Hand Side strut assembly should be ordered			
DOD-001-LH	1	BM404927/TDC1024	No Accessories Left Hand Side
DOD-001-RH	1	BM404927/TDC1024	No Accessories Right Hand Side
DOD-002-LH	1	BM404927/TDC1025	Bar and Winch Left Hand Side
DOD-002-RH	1	BM404927/TDC1025	Bar and Winch Right Hand Side
DOD-003-LH	1	FC404927/TDC1024	No Accessories Left Hand Side
DOD-003-RH	1	FC404927/TDC1024	No Accessories Right Hand Side
DOD-004-LH	1	FC404927/TDC1025	Bar and Winch Left Hand Side
DOD-004-RH	1	FC404927/TDC1025	Bar and Winch Right Hand Side
ADDITIONAL COMPONENTS			
DOD-4927	2	Strut Top	Replacement Strut Top

REAR SUSPENSION

PART NO.	Qty	DESCRIPTION	NOTES
SHOCK ABSORBERS			
FC43033	2	Foam Cell Shock	Up to 50mm Lift
BM403033	2	40mm Adjustable Shock	Up to 50mm Lift
COIL SPRINGS			
TDC1026	1	0-300KG Load (Pair)	50mm Lift
TDC1027	1	CONSTANT 300KG Load (Pair)	50mm Lift
TDC1028	1	CONSTANT 500KG Load (Pair)	50mm Lift
ADDITIONAL COMPONENTS			
TDSP-021	1	Swaybar Relocation Bracket	Required for ALL Lifted Vehicles
TDPR-026	1	Adjustable Panhard Rod	
AIR ASSIST BAGS			
TDAA-024	1	Coil Insert Bag Kit	Suit Standard Height Only
TDAA-025	1	Coil Insert Bag Kit	Suit 50mm Lift



FRONT SUSPENSION

ESTIMATED LIFT: 40mm

PART NO.	Qty	DESCRIPTION	NOTES
SHOCK ABSORBERS			
BMX3506	2	45mm Adjustable Shock	9 Stage Adjustable
COIL SPRINGS			
TDC1032	1	40mm Lift Spring (Pair)	
STEERING DAMPERS			
SS5930-P/S	1	Return To Centre Damper	
SV5930	1	9 Stage Adjustable Damper	
ADDITIONAL COMPONENTS			
TDSP-024	1	Front Swaybar Links	Required for ALL Lifted Vehicles

REAR SUSPENSION

PART NO.	Qty	DESCRIPTION	NOTES
SHOCK ABSORBERS			
BMX3504	2	45mm Adjustable Shock	9 Stage Adjustable
COIL SPRINGS			
TDC1033	1	0-400KG Load (Pair)	30mm Lift
TDC1034	1	CONSTANT 400KG Load (Pair)	30mm Lift
ADDITIONAL COMPONENTS			
TDSP-022	1	Rear Swaybar Links	Required for ALL Lifted Vehicles
AIR ASSIST BAGS			
TDAA-127	1	Bellows Bag Kit	Suit Standard Height Only
TDAA-128	1	Bellows Bag Kit	Suit Up To 50mm Lift

PLEASE NOTE:

Front lower shock mount is only partially welded from factory. It is recommended that a full weld around the entire mount is completed to prevent breakage.



FRONT SUSPENSION

ESTIMATED LIFT: 35mm

PART NO.	Qty	DESCRIPTION	NOTES
SHOCK ABSORBERS			
BD2057T	2	Nitrogen Gas Shock	Suit Up To 35mm Lift
TORSION BARS			
4WTB-1800	1	Replacement Torsion Bars	26mm/1232mm
Adjust Torsion bars after fitting shocks - Ensure a minimum of 60mm droop is maintained			

REAR SUSPENSION

PART NO.	Qty	DESCRIPTION	NOTES
SHOCK ABSORBERS			
BD1104T	2	Nitrogen Gas Shock	Suit OE Height
BM401104	2	40mm Adjustable Shock	
BD1105T	2	Nitrogen Gas Shock	Suit 35mm Lift
BM401105	2	40mm Adjustable Shock	
COIL SPRINGS			
TDC100	1	0-300KG Load (Pair)	35mm Lift
TDC100H	1	CONSTANT 300KG Load (Pair)	35mm Lift

REPLACEMENT BUSHINGS

PART NO.	Qty	DESCRIPTION	NOTES
QUANTITY PER SHOCK			
TW959	2	Suit Front Top Pin Mount	Pin Style Bushing
412772	1	Suit Front Bottom Eying	Eying Bushing
TW959	2	Suit Rear Top Pin Mount	Pin Style Bushing
404702	1	Suit Rear Bottom Eying	Eying Bushing



FRONT SUSPENSION

ESTIMATED LIFT: 40-80mm

PART NO.	Qty	DESCRIPTION	NOTES
SHOCK ABSORBERS			
FC31000	2	Foam Cell Shock	Suit Up To 40mm Lift
FC31001	2	Foam Cell Shock	Suit 60mm & 80mm Lift
COIL SPRINGS			
TDC836	1	40mm Lift Coil (Pair)	
TDC838L	1	60mm Lift Coil (Pair)	Suit 10/1998-2005 1.3L
TDC824	1	80mm Lift Coil (Pair)	
TDC824H	1	80mm Lift Coil (Pair)	Suit 10/1998-2005 1.3L/Bar/Winch
TDC838L	1	40mm Lift Coil (Pair)	
TDC824	1	60mm Lift Coil (Pair)	Suit 2005 On M13A VVT 1.3L
TDC824H	1	80mm Lift Coil (Pair)	
STEERING DAMPERS			
SD5610	1	Heavy Duty Replacement Damper	
SS5610-M/S	1	Return To Centre Damper	Includes Mounting Brackets
SV5610	1	9 Stage Adjustable Damper	
CASTER CORRECTION			
TDUK-063	1	3 Degree Caster Correction Bush	1 Kit Required 60mm & 80mm Lift
PANHARD RODS			
TDPR-009	1	Adjustable Panhard Rod	RHD Required 60mm & 80mm Lift
TDPR-011	1	Adjustable Panhard Rod	LHD Required 60mm & 80mm Lift
ADDITIONAL COMPONENTS			
TDUK-039	1	Replacement Radius Arm Bushes	0 Degree Adjustment
TDUK-030	1	Replacement Panhard Bush Kit	60mm & 80mm Lift
TDSK-022	1	ABS Relocation Bracket	Required 60mm & 80mm Lift

Fitting sheet (located page 243) must be completed when suspension fitted. Failure to comply may affect warranty.



REAR SUSPENSION

ESTIMATED LIFT: 40-80mm

PART NO.	Qty	DESCRIPTION	NOTES
SHOCK ABSORBERS			
FC31004	2	Foam Cell Shock	Suit Up To 40mm Lift
FC31006	2	Foam Cell Shock	Suit 60mm & 80mm Lift
COIL SPRINGS			
TDC837	1	40mm Lift Coil (Pair)	
TDC839L	1	60mm Lift Coil (Pair)	
TDC825	1	80mm Lift Coil (Pair)	
TDC826	1	80mm Lift Coil (Pair)	Overseas Model
ADDITIONAL COMPONENTS			
TDUK-039	1	Replacement Trailing Arm Bushings	
PANHARD ROD			
TDPR-010	1	Adjustable Panhard Rod	Required 60mm & 80mm Lift
TDUK-030	1	Replacement Panhard Bush Kit	60mm & 80mm Lift
BRAKE HOSE KITS			
TDBH-199	1	Brake Hose Kit 60mm & 80mm	Single Rear Hose (Front NOT Required)

REPLACEMENT BUSHINGS

PART NO.	Qty	DESCRIPTION	NOTES
QUANTITY PER SHOCK			
402267	2	Suit Front Top Pin Mount	Pin Style Bushing
412773	1	Suit Front Bottom Eying	Eying Bushing
412773	1	Suit Rear Top Eying	Eying Bushing



FRONT SUSPENSION

ESTIMATED LIFT: 40-80mm

PART NO.	Qty	DESCRIPTION	NOTES
SHOCK ABSORBERS			
FC31000	2	Foam Cell Shock	Suit 40mm Lift ONLY
FC31001	2	Foam Cell Shock	Suit 60mm & 80mm Lift
COIL SPRINGS			
TDC1000	1	40mm Lift Coil (Pair)	
TDC1001	1	60mm Lift Coil (Pair)	Fit TDUK-084 If Bar & Bar/Winch
TDC1002	1	80mm Lift Coil (Pair)	
STEERING DAMPERS			
EXT5928	1	Heavy Duty Replacement Damper	
SS5928-P/S	1	Return To Centre Damper	
SV5928	1	9 Stage Adjustable Damper	
CASTER CORRECTION			
TDUK-063	1	3 Degree Caster Correction Bush	1 Kit Required 60mm & 80mm Lift
PANHARD RODS			
TDPR-021	1	Adjustable Panhard Rod	RHD Required 60mm & 80mm Lift
TDPR-023	1	Adjustable Panhard Rod	LHD ONLY
ADDITIONAL COMPONENTS			
TDUK-039	1	Replacement Radius Arm Bushes	0 Degree Adjustment
TDUK-031	1	Replacement Panhard Bush Kit	
TDSP-016	1	ABS Relocation & Vacuum Hoses	Fit With ALL Kits
TDSP-017	1	Headlight Module Bracket	Fit With ALL Kits
TDSP-018	1	Crossmember Drop Kit	Fit With ALL Kits
TDUK-084	1	Front Coil Spacer (Pair)	Fit With Bar & Bar/Winch

Fitting sheet (located page 243) must be completed when suspension fitted. Failure to comply may affect warranty.



SUZUKI
JIMNY - JB74
2019 ON



REAR SUSPENSION

ESTIMATED LIFT: 40-80mm

PART NO.	Qty	DESCRIPTION	NOTES
SHOCK ABSORBERS			
FC31002	2	Foam Cell Shock	Suit 40mm Lift ONLY
FC31003	2	Foam Cell Shock	Suit 60mm & 80mm Lift
COIL SPRINGS			
TDC1003	1	40mm Lift Coil (Pair)	
TDC1004	1	60mm Lift Coil (Pair)	
TDC1005	1	80mm Lift Coil (Pair)	
ADDITIONAL COMPONENTS			
TDUK-039	1	Replacement Trailing Arm Bushings	
PANHARD ROD			
TDPR-010	1	Adjustable Panhard Rod	Required 60mm & 80mm Lift
TDUK-031	1	Replacement Panhard Bush Kit	
BRAKE HOSE KITS			
TDBH-401	1	Rubber Brake Hose Hit	60mm & 80mm Lift
TDBH-402	1	Braided Brake Hose Kit	60mm & 80mm Lift
TDBH-403	1	Rubber Brake Hose Kit	40mm Lift - Rear L/H Hose

REPLACEMENT BUSHINGS

PART NO.	Qty	DESCRIPTION	NOTES
QUANTITY PER SHOCK			
402267	2	Suit Front Top Pin Mount	Pin Style Bushing
412773	1	Suit Front Bottom Eying	Eying Bushing
412773	1	Suit Rear Top Eying	Eying Bushing
412773	1	Suit Rear Bottom Eying	Suit #31002 ONLY

All prices exclude freight. Include only permanent accessories & weights when selecting springs. Towing weight is not included.



FRONT SUSPENSION

ESTIMATED LIFT: 50mm

PART NO.	Qty	DESCRIPTION	NOTES
SHOCK ABSORBERS			
BD1102T	2	Nitrogen Gas Shock	Suit Up To 50mm Lift
LEAF SPRINGS			
1 Left Hand Side and 1 Right Hand Side leaf spring pack should be ordered			
T61-LH	1	50mm Lift	Bar Left Hand Side
T61-RH	1	50mm Lift	Bar Right Hand Side
ADDITIONAL COMPONENTS			
SD14030	1	Heavy Duty Replacement Damper	
SS5611-M/S	1	Return To Centre Damper	
ADDITIONAL COMPONENTS			
TDUK-013	1	Urethane Shackle Bushing Kit	
TDUB-014	1	U-Bolt Kit	Passenger Side
TDUB-013	1	U-Bolt Kit	Driver Side
TDGS-656	1	Greasable Shackle Kit	

REPLACEMENT BUSHINGS

PART NO.	Qty	DESCRIPTION	NOTES
QUANTITY PER SHOCK			
TW959	2	Suit Front Top Pin Mount	Pin Style Bushing
404702	1	Suit Front Bottom Eying	Eying Bushing
404702	2	Suit Rear Top & Bottom Eying	Eying Bushing

Fitting sheet (located page 243) must be completed when suspension fitted. Failure to comply may affect warranty.



SUZUKI

SIERRA - LEAF SPRING

1975 - 1999



REAR SUSPENSION

ESTIMATED LIFT: 50mm

PART NO.	Qty	DESCRIPTION	NOTES
SHOCK ABSORBERS			
BD1364T	2	Nitrogen Gas Shock	Suit OE Height
BD1366T	2	Nitrogen Gas Shock	Suit 50mm Lift
BD1102T	2	Nitrogen Gas Shock	Suit OE Height LJ80 & 80V
BD1104T	2	Nitrogen Gas Shock	Suit 50mm Lift LJ80 & 80V
LEAF SPRINGS			
1 Left Hand Side and 1 Right Hand Side leaf spring pack should be ordered			
T62-LH	1	50mm Lift	Left Hand Side
T62-RH	1	50mm Lift	Right Hand Side
ADDITIONAL COMPONENTS			
TDUK-013	1	Urethane Shackle Bushing Kit	
TDUB-014	2	U-Bolt Kit	
TDGS-656	1	Greasable Shackle Kit	

All prices exclude freight. Include only permanent accessories & weights when selecting springs. Towing weight is not included.





SUZUKI

VITARA - INC GRAND VITARA & XL7 07/1988 - 2006



FRONT SUSPENSION

ESTIMATED LIFT: 30mm

PART NO.	Qty	DESCRIPTION	NOTES
SHOCK ABSORBERS			
BDS4613	2	Mini Strut Replacement	OE Height
BDS4000LR	2	Mini Strut (Include Camber Bolt)	30mm Lift
COIL SPRINGS			
TDC814	1	30mm Lift Spring (Pair)	88-97 1.6L SWB
TDC816	1	30mm Lift Spring (Pair)	97-99 2.0L SWB & 91-97 1.6L LWB
TDC818	1	30mm Lift Spring (Pair)	95-03/98 2.0L V6 LWB
TDC834SL	1	30mm Lift Spring (Pair)	98-05 1.6L SWB & 2.0L LWB
TDC834	1	30mm Lift Spring (Pair)	98-05 2.5L V6 LWB
TDC834H	1	30mm Lift Spring (Pair)	01-06 2.7L V6 XL7 LWB
STEERING DAMPERS			
SS5614-M/S	1	Return To Centre Damper	07/1988-1998 Manual Steering

REPLACEMENT BUSHINGS

PART NO.	Qty	DESCRIPTION	NOTES
QUANTITY PER SHOCK			
TW959	2	Suit Rear Top Pin Mount	Pin Style Bushing
4W-SPF420-02	1	Suit Rear Bottom Eye	Eye Style Bushing

Fitting sheet (located page 243) must be completed when suspension fitted. Failure to comply may affect warranty.



SUZUKI

VITARA - INC GRAND VITARA & XL7 07/1988 - 2006



REAR SUSPENSION

ESTIMATED LIFT: 30mm

PART NO.	Qty	DESCRIPTION	NOTES
SHOCK ABSORBERS			
FC31005	2	Foam Cell Shock	Up To 30mm Lift
COIL SPRINGS			
TDC815	1	0-300KG Load (Pair)	30mm Lift 88-3/98 SWB
TDC817	1	0-300KG Load (Pair)	30mm Lift 91-3/98 LWB
TDC835SL	1	0-300KG Load (Pair)	30mm Lift 4/98-7/05 SWB
TDC835	1	0-300KG Load (Pair)	30mm Lift 4/98-7/05 LWB
TDC838	1	0-300KG Load (Pair)	30mm 7/01-06 XL-7 ONLY
ADDITIONAL COMPONENTS			
TDPR-024	1	Adjustable Panhard Rod	Suit 04-1998/2006

All prices exclude freight. Include only permanent accessories & weights when selecting springs. Towing weight is not included.



TOYOTA

FORTUNER

2004/12 - /2015



FRONT SUSPENSION

ESTIMATED LIFT: 40mm

PART NO.	Qty	DESCRIPTION	NOTES
SHOCK ABSORBERS			
FC404600	2	Foam Cell Strut	
BM404600	2	40mm Adjustable Strut	9 Stage Adjustable
COIL SPRINGS			
TDC974S	1	OE Height ONLY (Pair)	OE Replacement ONLY
TDC974	1	40mm Lift Spring (Pair)	Petrol/Diesel/Bar
TDC974H	1	40mm Lift Spring (Pair)	Petrol/Diesel/Bar/Winch
COMPLETE STRUT ASSEMBLY			
1 Left Hand Side and 1 Right Hand Side strut assembly should be ordered			
TOY-026/01-LH	1	BM404600/TDC974	Bar Left Hand Side
TOY-026/01-RH	1	BM404600/TDC974	Bar Right Hand Side
TOY-026/02-LH	1	BM404600/TDC974H	Bar/Winch Left Hand Side
TOY-026/02-RH	1	BM404600/TDC974H	Bar/Winch Right Hand Side
TOY-026/03-LH	1	FC404600/TDC974	Bar Left Hand Side
TOY-026/03-RH	1	FC404600/TDC974	Bar Right Hand Side
TOY-026/04-LH	1	FC404600/TDC974H	Bar/Winch Left Hand Side
TOY-026/04-RH	1	FC404600/TDC974H	Bar/Winch Right Hand Side
ADDITIONAL COMPONENTS			
TOY-1083	2	Strut Top	Replacement Strut Top

Fitting sheet (located page 243) must be completed when suspension fitted. Failure to comply may affect warranty.



TOYOTA

FORTUNER

2004/12 - 2015



REAR SUSPENSION

ESTIMATED LIFT: 40mm

PART NO.	Qty	DESCRIPTION	NOTES
SHOCK ABSORBERS			
FC41113	2	Foam Cell Shock	Up To 40mm Lift
BM401113	2	40mm Adjustable Shock	Up To 40mm Lift
COIL SPRINGS			
TDC912	1	0-300KG Load (Pair)	40mm Lift
TDC912L	1	CONSTANT 300KG Load (Pair)	40mm Lift
TDC912HL	1	CONSTANT 500KG Load (Pair)	40mm Lift

REPLACEMENT BUSHINGS

PART NO.	Qty	DESCRIPTION	NOTES
QUANTITY PER SHOCK			
ADJ300/40A	1	Suit Front Bottom Eying	Eying Bonded Bushing
ADJ00191	1	Suit Rear Bottom Eying	Eying Bushing
TW959	2	Suit Rear Top Pin	Pin Style Bushing

All prices exclude freight. Include only permanent accessories & weights when selecting springs. Towing weight is not included.





FRONT SUSPENSION

ESTIMATED LIFT: 40mm

PART NO.	Qty	DESCRIPTION	NOTES
SHOCK ABSORBERS			
FC404600	2	Foam Cell Strut	
BM404600	2	40mm Adjustable Shock	9 Stage Adjustable
COIL SPRINGS			
TDC974	1	40mm Lift Spring (Pair)	Diesel/No Bar
TDC983	1	40mm Lift Spring (Pair)	Diesel/Bar
TDC974H	1	40mm Lift Spring (Pair)	Diesel/Bar/Winch
COMPLETE STRUT ASSEMBLY			
1 Left Hand Side and 1 Right Hand Side strut assembly should be ordered			
TOY-026/01-LH	1	BM404600/TDC974	Diesel/No Bar Left Hand Side
TOY-026/01-RH	1	BM404600/TDC974	Diesel/No Bar Right Hand Side
TOY-027/02-LH	1	BM404600/TDC983	Diesel/Bar Left Hand Side
TOY-027/02-RH	1	BM404600/TDC983	Diesel/Bar Right Hand Side
TOY-027/03-LH	1	BM404600/TDC974H	Diesel/Bar/Winch Left Hand Side
TOY-027/03-RH	1	BM404600/TDC974H	Diesel/Bar/Winch Right Hand Side
TOY-026/03-LH	1	FC404600/TDC974	Diesel/No Bar Left Hand Side
TOY-026/03-RH	1	FC404600/TDC974	Diesel/No Bar Right Hand Side
TOY-027/06-LH	1	FC404600/TDC983	Diesel/Bar Left Hand Side
TOY-027/06-RH	1	FC404600/TDC983	Diesel/Bar Right Hand Side
TOY-027/07-LH	1	FC404600/TDC974H	Diesel/Bar/Winch Left Hand Side
TOY-027/07-RH	1	FC404600/TDC974H	Diesel/Bar/Winch Right Hand Side
ADDITIONAL COMPONENTS			
TOY-1083	2	Strut Top	Replacement Strut Top
TDCA-002	1	Upper Control Arms (Pair)	Suit Up To 50mm Lift
TDSK-001	1	Bush Kit for TDCA-002	Replacement Bush Kit
TDSK-002	1	Ball Joint Kit for TDCA-002	Replacement Ball Joint

PLEASE NOTE:

Fitment of Tough Dog upper control arms to vehicles that have lifts fitted greater than 50mm may suffer from premature ball joint failure due to longer droop lengths. The use of strut spacers may also effect the performance and longevity of the UCA ball joint due to the limitations of the spherical bearing housing being breached or bound at full suspension droop. There will be no warranty either expressed or implied if the vehicle is used out of legal driving conditions that will include but is not limited to jumping of the vehicle.

Fitting sheet (located page 243) must be completed when suspension fitted. Failure to comply may affect warranty.



TOYOTA

FORTUNER - GUN 156

2015 ON



REAR SUSPENSION

ESTIMATED LIFT: 40mm

PART NO.	Qty	DESCRIPTION	NOTES
SHOCK ABSORBERS			
FC43016	2	Foam Cell Shock	Up To 40mm Lift
BM403016	2	40mm Adjustable Shock	Up To 40mm Lift
COIL SPRINGS			
TDC913L	1	0-300KG Load (Pair)	40mm Lift
TDC913HL	1	CONSTANT 300KG Load (Pair)	40mm Lift
TDC913VHL	1	CONSTANT 500KG Load (Pair)	40mm Lift
ADDITIONAL COMPONENTS			
TDSP-010	1	Transmission Spacer Kit	Must Be Fitted With ALL Kits
TDPR-020	1	Adjustable Panhard Rod	
AIR ASSIST BAGS			
TDAA-003	1	Coil Insert Bag Kit	Suit 40mm Lift
TDAA-019	1	Coil Insert Bag Kit	Suit Standard Heigh ONLY

REPLACEMENT BUSHINGS

PART NO.	Qty	DESCRIPTION	NOTES
QUANTITY PER SHOCK			
ADJ300/40A	1	Suit Front Bottom Eying	Eying Bonded Bushing
415024	1	Suit Rear Bottom Eying	Eying Bushing

All prices exclude freight. Include only permanent accessories & weights when selecting springs. Towing weight is not included.



FRONT SUSPENSION

ESTIMATED LIFT: 50mm

PART NO.	Qty	DESCRIPTION	NOTES
SHOCK ABSORBERS			
FC41127B	2	Foam Cell Shock	Up To 50mm Lift
TORSION BARS			
4WTB-1646	1	Replacement Torsion Bars	26mm/1064mm
Adjust Torsion bars after fitting shocks - Ensure a minimum of 60mm droop is maintained			
STEERING DAMPERS			
EXT5510	1	Heavy Duty Replacement Damper	
SS5510-P/S	1	Return To Centre Damper	

REPLACEMENT BUSHINGS

PART NO.	Qty	DESCRIPTION	NOTES
QUANTITY PER SHOCK			
TW959	1	Suit Front Top Pin	Pin Style Bushing
TW038-16	1	Suit Front Bottom Eye	Eyering Bushing
ADJ00191	1	Suit Rear Top & Bottom Eye	Eyering Bushing

Fitting sheet (located page 243) must be completed when suspension fitted. Failure to comply may affect warranty.



TOYOTA

4RUNNER - IFS/LEAF REAR

11/1985 - 1989



REAR SUSPENSION

ESTIMATED LIFT: 50mm

PART NO.	Qty	DESCRIPTION	NOTES
SHOCK ABSORBERS			
BD1350T	2	Nitrogen Gas Shock	
FC41350	2	Foam Cell Shock	Suit OE Height
BM401350	2	40mm Adjustable Shock	
BD1377T	2	Nitrogen Gas Shock	
FC41377	2	Foam Cell Shock	Suit 50mm Lift
BM401377	2	40mm Adjustable Shock	
LEAF SPRINGS			
1 Left Hand Side and 1 Right Hand Side leaf spring pack should be ordered			
T46C-LH	1	0-300KG Load	50mm Lift Left Hand Side
T46C-RH	1	0-300KG Load	50mm Lift Right Hand Side
T46L-LH	1	CONSTANT 300KG Load	50mm Lift Left Hand Side
T46L-RH	1	CONSTANT 300KG Load	50mm Lift Right Hand Side
ADDITIONAL COMPONENTS			
TDUK-015	1	Urethane Shackle Bushing Kit	
TDUB-016	2	U-Bolt Kit	
TDGP-385	1	Greasable Pin Kit	
TDGS-386	1	Greasable Shackle Kit	

All prices exclude freight. Include only permanent accessories & weights when selecting springs. Towing weight is not included.



FRONT SUSPENSION

ESTIMATED LIFT: 50mm

PART NO.	Qty	DESCRIPTION	NOTES
SHOCK ABSORBERS			
FC41127B	2	Foam Cell Shock	Up To 50mm Lift
TORSION BARS			
4WTB-1646	1	Replacement Torsion Bars	26mm/1064mm
Adjust Torsion bars after fitting shocks - Ensure a minimum of 60mm droop is maintained			
STEERING DAMPERS			
EXT5510	1	Heavy Duty Replacement Damper	
SS5510-P/S	1	Return To Centre Damper	

REPLACEMENT BUSHINGS

PART NO.	Qty	DESCRIPTION	NOTES
QUANTITY PER SHOCK			
TW959	2	Suit Front Top Pin	Pin Style Bushing
TW038-16	1	Suit Front Bottom Eying	Eying Bushing
TW959	2	Suit Rear Top Pin	Pin Style Bushing
ADJ00191	1	Suit Rear Bottom Eye	Eying Bushing

Fitting sheet (located page 243) must be completed when suspension fitted. Failure to comply may affect warranty.



TOYOTA

4RUNNER - IFS/COIL REAR

1989 - 1996



REAR SUSPENSION

ESTIMATED LIFT: 50mm

PART NO.	Qty	DESCRIPTION	NOTES
SHOCK ABSORBERS			
FC41108	2	Foam Cell Shock	Suit OE Height
BM401108	2	40mm Adjustable Shock	
FC41113	2	Foam Cell Shock	Suit 50mm Lift
BM401113	2	40mm Adjustable Shock	
COIL SPRINGS			
TDC946S	1	0-300KG Load (Pair)	OE Height
TDC946	1	0-300KG Load (Pair)	50mm Lift
TDC946H	1	CONSTANT 300KG Load (Pair)	50mm Lift
PANHARD ROD			
TDPR-008	1	Adjustable Panhard Rod	

All prices exclude freight. Include only permanent accessories & weights when selecting springs. Towing weight is not included.





FRONT SUSPENSION

ESTIMATED LIFT: 50mm

PART NO.	Qty	DESCRIPTION	NOTES
SHOCK ABSORBERS			
BD1134T	2	Nitrogen Gas Shock	
FC41134	2	Foam Cell Shock	Suit OE Height
BM401134	2	40mm Adjustable Shock	
BD1109T	2	Nitrogen Gas Shock	
FC41109	2	Foam Cell Shock	Suit 50mm Lift
BM401109	2	40mm Adjustable Shock	
LEAF SPRINGS			
1 Left Hand Side and 1 Right Hand Side leaf spring pack should be ordered			
T75-LH	1	50mm Lift Spring	Bar Left Hand Side
T75-RH	1	50mm Lift Spring	Bar Right Hand Side
T78-LH	1	50mm Lift Spring	Bar/Winch Left Hand Side
T78-RH	1	50mm Lift Spring	Bar/Winch Right Hand Side
STEERING DAMPERS			
EXT5500	1	Heavy Duty Replacement Damper	
SS5500-M/S	1	Return To Centre Damper	Suit Manual Steering
SS5500-P/S	1	Return To Centre Damper	Suit Power Steering
SV5500	1	9 Stage Adjustable Damper	
ADDITIONAL COMPONENTS			
TDUK-014	1	Urethane Shackle Bushing Kit	
TDUB-015	1	U-Bolt Kit	Suit D/S - 1 Kit Required
TDUB-016	1	U-Bolt Kit	Suit P/S - 1 Kit Required
TDGP-385	1	Greasable Pin Kit	
TDGS-384	1	Greasable Shackle Kit	
TDDL-001	1	Adjustable Diff Locator	Fit With ALL Lift Kits

Fitting sheet (located page 243) must be completed when suspension fitted. Failure to comply may affect warranty.



REAR SUSPENSION

ESTIMATED LIFT: 50mm

PART NO.	Qty	DESCRIPTION	NOTES
SHOCK ABSORBERS			
BD1382T	2	Nitrogen Gas Shock	
FC41382	2	Foam Cell Shock	Suit 04/1979-1983 OE Height
BM401382	2	40mm Adjustable Shock	
BD1388T	2	Nitrogen Gas Shock	
FC41388	2	Foam Cell Shock	Suit 04/1979-1983 50mm Lift
BM401388	2	40mm Adjustable Shock	
BD1350T	2	Nitrogen Gas Shock	
FC41350	2	Foam Cell Shock	Suit 11/1983-1997 OE Height
BM401350	2	40mm Adjustable Shock	
BD1377T	2	Nitrogen Gas Shock	
FC41377	2	Foam Cell Shock	Suit 11/1983-1997 50mm Lift
BM401377	2	40mm Adjustable Shock	
LEAF SPRINGS			
Where stated 1 Left Hand Side and 1 Right Hand Side leaf spring pack should be ordered			
T46C-LH	1	0-300KG Load	50mm Lift Spring Left Hand Side
T46C-RH	1	0-300KG Load	50mm Lift Spring Right Hand Side
T46L-LH	1	CONSTANT 300KG Load	50mm Lift Spring Left Hand Side
T46L-RH	1	CONSTANT 300KG Load	50mm Lift Spring Left Hand Side
BP-002-XHD	2	CONSTANT 500KG Load	50mm Lift Spring
ADDITIONAL COMPONENTS			
TDUK-015	1	Urethane Shackle Bushing Kit	
TDUB-016	2	U-Bolt Kit	
TDGP-385	1	Greasable Pin Kit	
TDGS-386	1	Greasable Shackle Kit	



FRONT SUSPENSION

ESTIMATED LIFT: 50mm

PART NO.	Qty	DESCRIPTION	NOTES
SHOCK ABSORBERS			
FC41127B	2	Foam Cell Shock	Up To 50mm Lift
TORSION BARS			
4WTB-1646	1	Replacement Torsion Bars	26mm/1064mm
Adjust Torsion bars after fitting shocks - Ensure a minimum of 60mm droop is maintained			
STEERING DAMPERS			
EXT5510	1	Heavy Duty Replacement Damper	
SS5510-P/S	1	Return To Centre Damper	

REPLACEMENT BUSHINGS

PART NO.	Qty	DESCRIPTION	NOTES
QUANTITY PER SHOCK			
TW959	2	Suit Front Top Pin	Pin Style Bushing
TW038-16	1	Suit Front Bottom Eying	Eying Bushing
ADJ00191	2	SUit Rear Top & Bottom Eying	Eying Bushing

Fitting sheet (located page 243) must be completed when suspension fitted. Failure to comply may affect warranty.



TOYOTA

HILUX - TORSION BAR FRONT

10/1988 - 1997



REAR SUSPENSION

ESTIMATED LIFT: 50mm

PART NO.	Qty	DESCRIPTION	NOTES
SHOCK ABSORBERS			
BD1350T	2	Nitrogen Gas Shock	
FC41350	2	Foam Cell Shock	Suit OE Height
BM401350	2	40mm Adjustable Shock	
BD1377T	2	Nitrogen Gas Shock	
FC41377	2	Foam Cell Shock	Suit 50mm Lift
BM401377	2	40mm Adjustable Shock	
LEAF SPRINGS			
BP-007	2	0-300KG Load	50mm Lift
BP-007H	2	CONSTANT 300KG Load	50mm Lift
BP-007HH	2	CONSTANT 500KG Load	50mm Lift
ADDITIONAL COMPONENTS			
TDUK-065	1	Urethane Shackle Bushing Kit	
TDUB-016	2	U-Bolt Kit	
TDGS-386/1	1	Greasable Shackle Kit	
TDGP-668	1	Greasable Pin Kit	

All prices exclude freight. Include only permanent accessories & weights when selecting springs. Towing weight is not included.





FRONT SUSPENSION

ESTIMATED LIFT: 50mm

PART NO.	Qty	DESCRIPTION	NOTES
SHOCK ABSORBERS			
FC41127B	2	Foam Cell Shock	Up To 50mm Lift
TORSION BARS			
4WTB-1646	1	Replacement Torsion Bars	26mm/1064mm
Adjust Torsion bars after fitting shocks - Ensure a minimum of 60mm droop is maintained			
STEERING DAMPERS			
EXT5510	1	Heavy Duty Replacement Damper	
SS5513-P/S	1	Return To Centre Damper	
SV5513	1	9 Stage Adjustable Damper	

REPLACEMENT BUSHINGS

PART NO.	Qty	DESCRIPTION	NOTES
QUANTITY PER SHOCK			
TW959	2	Suit Front Top Pin	Pin Style BUshing
TW038-16	1	Suit Front Bottom Eye	Eyering Bushing
ADJ00191	2	Suit Rear Top & Bottom Eyering	Eyering Bushing

Fitting sheet (located page 243) must be completed when suspension fitted. Failure to comply may affect warranty.



TOYOTA

HILUX - TORSION BAR FRONT

10/1997 - 2005



REAR SUSPENSION

ESTIMATED LIFT: 50mm

PART NO.	Qty	DESCRIPTION	NOTES
SHOCK ABSORBERS			
BD1350T	1	Nitrogen Gas Shock (D/S)	
BD1377T	1	Nitrogen Gas Shock (P/S)	
FC41350	1	Foam Cell Shock (D/S)	Suit OE Height
FC41377	1	Foam Cell Shock (P/S)	
BM401350	1	40mm Adjustable Shock (D/S)	
BM401377	1	40mm Adjustable (P/S)	
BD1377T	2	Nitrogen Gas Shock	Suit 50mm Lift
FC41377	2	Foam Cell Shock	
BM401377	2	40mm Adjustable Shock	
LEAF SPRINGS			
Where stated 1 Left Hand Side and 1 Right Hand Side leaf spring pack should be ordered			
T79C-LH	1	0-300KG Load	50mm Lift Left Hand Side
T79C-RH	1	0-300KG Load	50mm Lift Right Hand Side
T79L-LH	1	CONSTANT 300KG Load	50mm Lift Left Hand Side
T79L-RH	1	CONSTANT 300KG Load	50mm Lift Right Hand Side
T79LL-LH	1	CONSTANT 500KG Load	50mm Lift Left Hand Side
T79LL-RH	1	CONSTANT 500KG Load	50mm Lift Right Hand Side
ADDITIONAL COMPONENTS			
TDUK-038	1	Urethane Shackle Bushing Kit	
TDUB-016	2	U-Bolt Kit	
TDGS-386/1	1	Greasable Shackle Kit	
TDGP-668	1	Greasable Pin Kit	

All prices exclude freight. Include only permanent accessories & weights when selecting springs. Towing weight is not included.



FRONT SUSPENSION

ESTIMATED LIFT: 40mm

PART NO.	Qty	DESCRIPTION	NOTES
SHOCK ABSORBERS			
FC404600	2	Foam Cell Strut	
BM404600	2	40mm Adjustable Strut	9 Stage Adjustable
COIL SPRINGS			
TDC974S	1	OE Height ONLY (Pair)	OE Replacement ONLY
TDC974	1	40mm Lift Spring (Pair)	Petrol/Diesel/Bar
TDC974H	1	40mm Lift Spring (Pair)	Petrol/Diesel/Bar/Winch
COMPLETE STRUT ASSEMBLY			
1 Left Hand Side and 1 Right Hand Side strut assembly should be ordered			
TOY-026/01-LH	1	BM404600/TDC974	Bar Left Hand Side
TOY-026/01-RH	1	BM404600/TDC974	Bar Right Hand Side
TOY-026/02-LH	1	BM404600/TDC974H	Bar/Winch Left Hand Side
TOY-026/02-RH	1	BM404600/TDC974H	Bar/Winch Right Hand Side
TOY-026/03-LH	1	FC404600/TDC974	Bar Left Hand Side
TOY-026/03-RH	1	FC404600/TDC974	Bar Right Hand Side
TOY-026/04-LH	1	FC404600/TDC974H	Bar/Winch Left Hand Side
TOY-026/04-RH	1	FC404600/TDC974H	Bar/Winch Right Hand Side
ADDITIONAL COMPONENTS			
TOY-1083	2	Strut Top	Replacement Strut Top
TDSP-011	1	Sway Bar Spacer Kit	76mm Hole Spacing
TDCA-002	1	Upper Control Arms (Pair)	Suit Up To 50mm Lift
TDSK-001	1	Bush Kit for TDCA-002	Replacement Bush Kit
TDSK-002	1	Ball Joint Kit for TDCA-002	Replacement Ball Joint

PLEASE NOTE:

Fitment of Tough Dog upper control arms to vehicles that have lifts fitted greater than 50mm may suffer from premature ball joint failure due to longer droop lengths. The use of strut spacers may also effect the performance and longevity of the UCA ball joint due to the limitations of the spherical bearing housing being breached or bound at full suspension droop. There will be no warranty either expressed or implied if the vehicle is used out of legal driving conditions that will include but is not limited to jumping of the vehicle.

Fitting sheet (located page 243) must be completed when suspension fitted. Failure to comply may affect warranty.



TOYOTA

HILUX - KUN26, GGN25R (COIL/LEAF)

04/2005 - 2015



REAR SUSPENSION

ESTIMATED LIFT: 40mm

PART NO.	Qty	DESCRIPTION	NOTES
SHOCK ABSORBERS			
FC41350	2	Foam Cell Shock	Suit OE Height ONLY
BM401350	2	40mm Adjustable Shock	
FC41376	2	Foam Cell Shock	Suit 40mm Lift ONLY
BM401376	2	40mm Adjustable Shock	
LEAF SPRINGS			
T80C	2	0-300KG Load	40mm Lift
T80L	2	CONSTANT 300KG Load	40mm Lift
T80LL	2	CONSTANT 500KG Load	40mm Lift
ADDITIONAL COMPONENTS			
TDUK-067	1	Urethane Shackle Bushing Kit	
TDUB-016	2	U-Bolt Kit	
TDGS-389	1	Greasable Shackle Kit	
TDGP-668	1	Greasable Pin Kit	
AIR ASSIST BAGS			
TDAA-112	1	Bellows Bag Kit	Suit 40mm Lift
TDAA-123	1	Bellows Bag Kit	Suit Standard Height ONLY

REPLACEMENT BUSHINGS

PART NO.	Qty	DESCRIPTION	NOTES
QUANTITY PER SHOCK			
ADJ300/40A	1	Suit Front Bottom Eying	Eying Bonded Bushing
ADJ00191	2	Suit Rear Top & Bottom Eying	Eying Bushing

All prices exclude freight. Include only permanent accessories & weights when selecting springs. Towing weight is not included.



TOYOTA

HILUX - GUN125R, 126R, GGN125R (COIL/LEAF) 10/2015 ON



FRONT SUSPENSION

ESTIMATED LIFT: 40mm

PART NO.	Qty	DESCRIPTION	NOTES
SHOCK ABSORBERS			
FC404600	2	Foam Cell Strut	
BM404600	2	40mm Adjustable Strut	9 Stage Adjustable
COIL SPRINGS			
TDC983S	1	OE Height ONLY (Pair)	OE Replacement ONLY
TDC983	1	40mm Lift Spring (Pair)	Petrol/Diesel/No Bar
TDC974H	1	40mm Lift Spring (Pair)	Petrol/Diesel/Bar
TDC974HH	1	40mm Lift Spring (Pair)	Petrol/Diesel/Bar/Winch
COMPLETE STRUT ASSEMBLY			
1 Left Hand Side and 1 Right Hand Side strut assembly should be ordered			
TOY-027/01-LH	1	BM404600/TDC983S	OE ONLY Left Hand Side
TOY-027/01-RH	1	BM404600/TDC983S	OE ONLY Right Hand Side
TOY-027/02-LH	1	BM404600/TDC983	No Bar Left Hand Side
TOY-027/02-RH	1	BM404600/TDC983	No Bar Right Hand Side
TOY-027/03-LH	1	BM404600/TDC974H	Bar Left Hand Side
TOY-027/03-RH	1	BM404600/TDC974H	Bar Right Hand Side
TOY-027/04-LH	1	BM404600/TDC974HH	Bar/Winch Left Hand Side
TOY-027/04-RH	1	BM404600/TDC974HH	Bar/Winch Right Hand Side
TOY-027/05-LH	1	FC404600/TDC983S	OE ONLY Left Hand Side
TOY-027/05-RH	1	FC404600/TDC983S	OE ONLY Right Hand Side
TOY-027/06-LH	1	FC404600/TDC983	No Bar Left Hand Side
TOY-027/06-RH	1	FC404600/TDC983	No Bar Right Hand Side
TOY-027/07-LH	1	FC404600/TDC974H	Bar Left Hand Side
TOY-027/07-RH	1	FC404600/TDC974H	Bar Right Hand Side
TOY-027/08-LH	1	FC404600/TDC974HH	Bar/Winch Left Hand Side
TOY-027/08-RH	1	FC404600/TDC974HH	Bar/Winch Right Hand Side
ADDITIONAL COMPONENTS			
TOY-1083	2	Strut Top	Replacement Strut Top
TDSP-023	1	Sway Bar Spacer Kit	86mm Hole Spacing Gen 8
TDCA-002	1	Upper Control Arms (Pair)	Suit Up To 50mm Lift
TDSK-001	1	Bush Kit for TDCA-002	Replacement Bush Kit
TDSK-002	1	Ball Joint Kit for TDCA-002	Replacement Ball Joint

Fitting sheet (located page 243) must be completed when suspension fitted. Failure to comply may affect warranty.



TOYOTA

HILUX - GUN125R, 126R, GGN125R (COIL/LEAF) 10/2015 ON



REAR SUSPENSION

ESTIMATED LIFT: 40mm

PART NO.	Qty	DESCRIPTION	NOTES
SHOCK ABSORBERS			
FC43014	2	Foam Cell Shock	Suit OE Height ONLY
BM403014	2	40mm Adjustable Shock	
FC43036	2	Foam Cell Shock	Suit 40mm Lift ONLY - Super Soft*
BD3015T	2	Nitrogen Gas Shock	Suit 40mm Lift - Comfort Use ONLY
FC43015	2	Foam Cell Shock	Suit 40mm Lift
BM403015	2	40mm Adjustable Shock	
LEAF SPRINGS			
T81C	2	0-300KG Load	40mm Lift
T81L	2	CONSTANT 300KG Load	40mm Lift
T81LL	2	CONSTANT 500KG Load	40mm Lift - Use #016HD U-Bolts
ADDITIONAL COMPONENTS			
TDUK-067	1	Urethane Shackle Bushing Kit	
TDUB-016	2	U-Bolt Kit	
TDUB-016HD	2	U-Bolt Kit	Fit With LL Springs Or With Airbags
TDGS-392	1	Greasable Shackle Kit	
TDGP-668	1	Greasable Pin Kit	
TDSP-010	1	Driveshaft Spacer Kit	Fit If Vibration Occurs
AIR ASSIST BAGS			
TDAA-113	1	Bellows Bag Kit	Suit 40mm Lift
TDAA-122	1	Bellows Bag Kit	Suit Standard Height ONLY

PLEASE NOTE:

Fit constant leaves only where constant load fitted - premature failure may occur

*FC43036 valving suitable for super comfort ONLY, shock control not suitable for constant 300KG or constant 500KG load. Do not use with these springs. Use this shock ONLY with 0-300KG load spring.

REPLACEMENT BUSHINGS

PART NO.	Qty	DESCRIPTION	NOTES
QUANTITY PER SHOCK			
ADJ300/40A	1	Suit Front Bottom Eying	Eying Bonded Bushing
ADJ00191	2	Suit Rear Top & Bottom Eying	Eying Bushing

PLEASE NOTE:

Fitment of Tough Dog upper control arms to vehicles that have lifts fitted greater than 50mm may suffer from premature ball joint failure due to longer droop lengths. The use of strut spacers may also effect the performance and longevity of the UCA ball joint due to the limitations of the spherical bearing housing being breached or bound at full suspension droop. There will be no warranty either expressed or implied if the vehicle is used out of legal driving conditions that will include but is not limited to jumping of the vehicle.

All prices exclude freight. Include only permanent accessories & weights when selecting springs. Towing weight is not included.





TOYOTA

2WD - HILUX WORKMATE

2015 ON



The 4x2 Tough Dog rear suspension upgrade allows a vehicle to maintain factory ride height while carrying heavy payloads for extended periods of time. The suspension upgrade is not designed to increase the vehicles' ride height like traditional Tough Dog suspension solutions, instead these solutions assist the vehicle to carry its maximum OEM payload without suspension sag. This kit has been designed to suit heavy load applications within the manufactures specifications and will not increase the allowable payload of the vehicle.

The 4x2 Tough Dog Suspension upgrade kit includes the rear only consisting of the below:

- 2 x Heavy Duty two stage rear Leaf Springs
- 41mm bore Foam Cell Shocks
- 2 x U-Bolt kits
- 1 x Urethane Bush kit

The following pages list application guides for popular makes and models.

REAR SUSPENSION

PART NO.	Qty	DESCRIPTION	NOTES
SHOCK ABSORBERS			
FC41350	2	Foam Cell Shock	
LEAF SPRINGS			
T82	2	0 - 1000KG	
ADDITIONAL COMPONENTS			
TDUK-086	1	Urethane Shackle Bushing Kit	
TDUB-017	2	U-Bolt Kit	

Fitting sheet (located page 243) must be completed when suspension fitted. Failure to comply may affect warranty.



THIS PAGE IS INTENTIONALLY BLANK

All prices exclude freight. Include only permanent accessories & weights when selecting springs. Towing weight is not included.



FRONT SUSPENSION

ESTIMATED LIFT: 50mm

PART NO.	Qty	DESCRIPTION	NOTES
SHOCK ABSORBERS			
FC41364	2	Foam Cell Shock	Suit OE Height
BM401364	2	40mm Adjustable Shock	
FC41366	2	41mm Foam Cell Shock	Suit 50mm Lift
BM401366	2	40mm Adjustable Shock	
LEAF SPRINGS			
BP-009	2	50mm Lift Spring - 25mm Eying	Petrol/Diesel/Bar
BP-009H	2	50mm Lift Spring - 25mm Eying	Petrol/Diesel/Bar/Winch
BP-011	2	50mm Lift Spring - 35mm Eying	Petrol/Diesel/Bar
BP-011H	2	50mm Lift Spring - 35mm Eying	Petrol/Diesel/Bar/Winch
STEERING DAMPERS			
EXT5511	1	Heavy Duty Replacement Damper	
SS5511-M/S	1	Return To Centre Damper	Suit Manual Steering
SS5511-P/S	1	Return To Centre Damper	Suit Power Steering
ADDITIONAL COMPONENTS			
TDUK-016	1	Urethane Shackle Bushing Kit	Suit 25mm Eye Spring
TDUK-012	1	Urethane Shackle Bushing Kit	Suit 35mm Eye Spring
TDUB-017	2	U-Bolt Kit	
TDGP-346	1	Greasable Pin Kit	Suit 25mm Eye Spring
TDGS-343	1	Greasable Shackle Kit	Suit 25mm Eye Spring
TDGP-351	1	Greasable Pin Kit	Suit 35mm Eye Spring
TDGS-348	1	Greasable Shackle Kit	Suit 35mm Eye Spring

Fitting sheet (located page 243) must be completed when suspension fitted. Failure to comply may affect warranty.



REAR SUSPENSION

ESTIMATED LIFT: 50mm

PART NO.	Qty	DESCRIPTION	NOTES
SHOCK ABSORBERS			
FC41366	2	Foam Cell Shock	Suit FJ40, FJ42 - OE Height
BM401366	2	40mm Adjustable Shock	Chassis #19114
FC41382	2	Foam Cell Shock	Suit FJ40, FJ42 - 50mm Lift & BJ40, BJ42 - OE Height
BM401382	2	40mm Adjustable Shock	Chassis #191115 On
FC41388	2	Foam Cell Shock	Suit BJ40, BJ42 - 50mm Lift
BM401388	2	40mm Adjustable Shock	Chassis #191115 On
LEAF SPRINGS			
BP-010	2	0-300KG Load	50mm Lift Spring - 25mm Eying
BP-010H	2	CONSTANT 300KG Load	50mm Lift Spring - 25mm Eying
BP-012	2	0-300KG Load	50mm Lift Spring - 35mm Eying
BP-012H	2	CONSTANT 300KG Load	50mm Lift Spring - 35mm Eying
ADDITIONAL COMPONENTS			
TDUK-016	1	Urethane Shackle Bushing Kit	Suit 25mm Eye Spring
TDUK-012	1	Urethane Shackle Bushing Kit	Suit 35mm Eye Spring
TDUB-017	2	U-Bolt Kit	
TDGP-346	1	Greasable Pin Kit	Suit 25mm Eye Spring
TDGS-343	1	Greasable Shackle Kit	Suit 25mm Eye Spring
TDGP-351	1	Greasable Pin Kit	Suit 35mm Eye Spring
TDGS-348	1	Greasable Shackle Kit	Suit 35mm Eye Spring

REPLACEMENT BUSHINGS

PART NO.	Qty	DESCRIPTION	NOTES
QUANTITY PER SHOCK			
404702	2	Suit Front Top & Bottom Eye	Eying Bushing
404702	2	Suit Rear Top & Bottom Eye	Eying Bushing



FRONT SUSPENSION

ESTIMATED LIFT: 50mm

PART NO.	Qty	DESCRIPTION	NOTES
SHOCK ABSORBERS			
FC41364	2	Foam Cell Shock	Suit OE Height
BM401364	2	40mm Adjustable Shock	
FC41366	2	Foam Cell Shock	Suit 50mm Lift
BM401366	2	40mm Adjustable Shock	
LEAF SPRINGS			
BP-013	2	50mm Lift Spring - 25mm Eying	Petrol/Diesel/Bar (45 SERIES)
BP-013H	2	50mm Lift Spring - 25mm Eying	Petrol/Diesel/Bar/Winch (45 SERIES)
BP-015	2	50mm Lift Spring - 35mm Eying	Petrol/Diesel/Bar (47 SERIES)
BP-015H	2	50mm Lift Spring - 35mm Eying	Petrol/Diesel/Bar/Winch (47 SERIES)
STEERING DAMPERS			
EXT5511	1	Heavy Duty Replacement Damper	
SS5511-M/S	1	Return To Centre Damper	Suit Manual Steering
SS5511-P/S	1	Return To Centre Damper	Suit Power Steering
ADDITIONAL COMPONENTS			
TDUK-016	1	Urethane Shackle Bushing Kit	Suit 25mm Eye Spring
TDUK-012	1	Urethane Shackle Bushing Kit	Suit 35mm Eye Spring
TDUB-017	1	U-Bolt Kit	
TDUB-018	1	U-Bolt Kit	
TDGP-346	1	Greasable Pin Kit	Suit 25mm Eye Spring
TDGS-343	1	Greasable Shackle Kit	Suit 25mm Eye Spring
TDGP-351	1	Greasable Pin Kit	Suit 35mm Eye Spring
TDGS-348	1	Greasable Shackle Kit	Suit 35mm Eye Spring

Fitting sheet (located page 243) must be completed when suspension fitted. Failure to comply may affect warranty.



REAR SUSPENSION

ESTIMATED LIFT: 50mm

PART NO.	Qty	DESCRIPTION	NOTES
SHOCK ABSORBERS			
FC41382	2	Foam Cell Shock	Suit OE Height
BM401382	2	40mm Adjustable Shock	
FC41388	2	Foam Cell Shock	Suit 50mm Lift
BM401388	2	40mm Adjustable Shock	
LEAF SPRINGS			
BP-014	2	0-300KG Load - 30mm Eying	45 SERIES
BP-014H	2	CONSTANT 300KG Load - 30mm Eying	
BP-016	2	0-300KG Load - 35mm Eying	47 SERIES
BP-016H	2	CONSTANT 300KG Load - 35mm Eying	
ADDITIONAL COMPONENTS			
TDUK-017	1	Urethane Shackle Bushing Kit	Suit 30mm Eye Spring
TDUK-012	1	Urethane Shackle Bushing Kit	Suit 35mm Eye Spring
TDUB-017	2	U-Bolt Kit	
TDGP-347	1	Greasable Pin Kit	Suit 30mm Eye Spring
TDGS-344/5	1	Greasable Shackle Kit	Suit 30mm Eye Spring
TDGP-351	1	Greasable Pin Kit	Suit 35mm Eye Spring
TDGS-349/5	1	Greasable Shackle Kit	Suit 35mm Eye Spring

REPLACEMENT BUSHINGS

PART NO.	Qty	DESCRIPTION	NOTES
QUANTITY PER SHOCK			
404702	2	Suit Front Top & Bottom Eye	Eying Bushing
404702	2	Suit Rear Top & Bottom Eye	Eying Bushing



TOYOTA

LANDCRUISER - 60, 61, 62 SERIES

11/1980 - 1990



FRONT SUSPENSION

ESTIMATED LIFT: 50mm

PART NO.	Qty	DESCRIPTION	NOTES
SHOCK ABSORBERS			
FC41113	2	Foam Cell Shock	Suit OE Height
BM401113	2	40mm Adjustable Shock	
FC41163	2	Foam Cell Shock	Suit 50mm Lift
BM401163	2	40mm Adjustable Shock	
LEAF SPRINGS			
T43L	2	50mm Lift Spring	Petrol/Diesel/Bar
T43H	2	50mm Lift Spring	Petrol/Diesel/Bar/Winch
T53	2	50mm Lift Spring	Factory T.Diesel/Bar
T53H	2	50mm Lift Spring	Factory T.Diesel/Bar/Winch
STEERING DAMPERS			
EXT5001	1	Heavy Duty Replacement Damper	Suit Power Steering
SS5001-P/S	1	Return To Centre Damper	
SV5001	1	9 Stage Adjustable Damper	
ADDITIONAL COMPONENTS			
TDUK-012	1	Urethane Shackle Bushing Kit	
TDUB-019	2	U-Bolt Kit	
TDGP-351	1	Greasable Pin Kit	
TDGS-348	1	Greasable Shackle Kit	
TAK-005	1	Offset King Pin	0.5 Degree
TAK-075	1	Offset King Pin	0.75 Degree
TAK-001	1	Offset King Pin	1.0 Degree

Fitting sheet (located page 243) must be completed when suspension fitted. Failure to comply may affect warranty.



TOYOTA

LANDCRUISER - 60, 61, 62 SERIES

11/1980 - 1990



REAR SUSPENSION

ESTIMATED LIFT: 50mm

PART NO.	Qty	DESCRIPTION	NOTES
SHOCK ABSORBERS			
FC41366	2	Foam Cell Shock	Suit OE Height
BM401366	2	40mm Adjustable Shock	11/80-10/85 ONLY
FC41382	2	Foam Cell Shock	Suit 50mm Lift ONLY
BM401382	2	40mm Adjustable Shock	11/80-10/85 ONLY
FC41350	2	Foam Cell Shock	Suit 50mm Lift ONLY
BM401350	2	40mm Adjustable Shock	10/85-90 ONLY
LEAF SPRINGS			
1 Left Hand Side and 1 Right Hand Side leaf spring pack should be ordered			
T44L-LH	1	0-300KG Load	50mm Lift Spring Left Hand Side
T44L-RH	1	0-300KG Load	50mm Lift Spring Right Hand Side
T44H-LH	1	CONSTANT 300KG Load	50mm Lift Spring Left Hand Side
T44H-RH	1	CONSTANT 300KG Load	50mm Lift Spring Right Hand Side
T44HM-LH	1	CONSTANT 500KG Load	50mm Lift Spring Left Hand Side
T44HM-RH	1	CONSTANT 500KG Load	50mm Lift Spring Right Hand Side
ADDITIONAL COMPONENTS			
TDUK-012	1	Urethane Shackle Bushing Kit	
TDUB-017	2	U-Bolt Kit	
TDGP-351	1	Greasable Pin Kit	
TDGS-357	1	Greasable Shackle Kit	

REPLACEMENT BUSHINGS

PART NO.	Qty	DESCRIPTION	NOTES
QUANTITY PER SHOCK			
TW959	2	Suit Front Top Pin	Pin Style Bushing
ADJ00191	1	Suit Front Bottom Eying	Eying Bushing
404702	2	Suit Rear Top & Bottom Eying	Eying Bushing #1382/1366
ADJ00191	2	Suit Rear Top & Bottom Eying	Eying Bushing #1350

All prices exclude freight. Include only permanent accessories & weights when selecting springs. Towing weight is not included.



FRONT SUSPENSION

ESTIMATED LIFT: 40mm

PART NO.	Qty	DESCRIPTION	NOTES
SHOCK ABSORBERS			
FC41005	2	Foam Cell Shock	OE Height
FC41007	2	Foam Cell Shock	40mm Lift
COIL SPRINGS			
TDC941L	1	40mm Lift Spring (Pair)	Suit Petrol/Diesel/Bar
STEERING DAMPERS			
EXT5001	1	Heavy Duty Replacement Damper	
SS5001-P/S	1	Return To Centre Damper	
SV5001	1	9 Stage Adjustable Damper	
ADDITIONAL COMPONENTS			
TDUK-042	1	Radius Rod To Diff	2 Kits Required
TDUK-041	1	Radius Rod To Chassis	1 Kit Required

REAR SUSPENSION

PART NO.	Qty	DESCRIPTION	NOTES
SHOCK ABSORBERS			
FC43005	1	Foam Cell Shock	OE Height - D/S
FC41107	1	Foam Cell Shock	OE Height - P/S
FC41350	1	Foam Cell Shock	40mm Lift - D/S
FC41108	1	Foam Cell Shock	40mm Lift - P/S
COIL SPRINGS			
TDC942L	1	0-300KG Load (Pair)	40mm Lift Spring
ADDITIONAL COMPONENTS			
TDUK-042	1	Radius Rod To Diff	2 Kits Required
TDUK-041	1	Radius Rod To Chassis	1 Kit Required

REPLACEMENT BUSHINGS

PART NO.	Qty	DESCRIPTION	NOTES
QUANTITY PER SHOCK			
TW959	4	Suit Front Top & Bottom Pin	Pin Style Bushing
ADJ00191	2	Suit Rear Top & Bottom Eying	Eying Bushing #1108 & #1107
TW959	2	Suit Rear Top Pin	Pin Style Bushing
ADJ00191	2	Suit Rear Top & Bottom Eying	

Fitting sheet (located page 243) must be completed when suspension fitted. Failure to comply may affect warranty.



FRONT SUSPENSION

ESTIMATED LIFT: 50mm

PART NO.	Qty	DESCRIPTION	NOTES
SHOCK ABSORBERS			
FC41050	2	Foam Cell Shock	Up To 50mm Lift
BM401050	2	40mm 9 Stage Adjustable	Up To 50mm Lift
BMX1050/2	2	45mm 9 Stage Adjustable	50mm Lift
TDR1050	2	'Ralph' Shock	Up To 50mm Lift
COIL SPRINGS			
TDC950SL	1	50mm Lift Spring (Pair)	Petrol/Diesel/Bar
TDC950L	1	50mm Lift Spring (Pair)	Petrol/Diesel/Bar/Winch
STEERING DAMPERS			
EXT5001	1	Heavy Duty Replacement Damper	
SS5001-P/S	1	Return To Centre Damper	
SV5001	1	9 Stage Adjustable Damper	

REAR SUSPENSION

PART NO.	Qty	DESCRIPTION	NOTES
SHOCK ABSORBERS			
FC41377	2	Foam Cell Shock	50mm Lift
BM401377	2	40mm 9 Stage Adjustable Shock	50mm Lift
BMX1377/2	2	45mm 9 Stage Adjustable Shock	50mm Lift
TDR1377	2	'Ralph' Shock	50mm Lift
LEAF SPRINGS			
1 Left Hand Side and 1 Right Hand Side leaf spring pack should be ordered			
T44L-LH	1	0-300KG Load	50mm Lift Spring Left Hand Side
T44L-RH	1	0-300KG Load	50mm Lift Spring Right Hand Side
T44H-LH	1	CONSTANT 300KG Load	50mm Lift Spring Left Hand Side
T44H-RH	1	CONSTANT 300KG Load	50mm Lift Spring Right Hand Side
ADDITIONAL COMPONENTS			
TDUK-012	1	Urethane Shackle Bushing Kit	1 Kit Required
TDUB-017	2	U-Bolt Kit	2 Kits Required



FRONT SUSPENSION

ESTIMATED LIFT: 50mm

PART NO.	Qty	DESCRIPTION	NOTES
SHOCK ABSORBERS			
FC41113	2	Foam Cell Shock	OE Height
BM401113	2	40mm Adjustable Shock	
FC41163	2	Foam Cell Shock	50mm Lift
BM401163	2	40mm Adjustable Shock	
BMX1163/2	2	45mm Adjustable Shock	
TDR1163B	2	'Ralph' Shock	
LEAF SPRINGS			
T52	2	50mm Lift Spring	Petrol/Diesel/Bar
STEERING DAMPERS			
EXT5001	1	Heavy Duty Replacement Damper	
SS5001-P/S	1	Return To Centre Damper	
SV5001	1	9 Stage Adjustable Damper	
ADDITIONAL COMPONENTS			
TDUK-012	1	Urethane Shackle Bushing Kit	
TDUB-019	2	U-Bolt Kit	
TDGP-351	1	Greasable Pin Kit	
TDGS-357	1	Greasable Shackle Kit	
TAK-005	1	Offset King Pin	0.5 Degree
TAK-075	1	Offset King Pin	0.75 Degree
TAK-001	1	Offset King Pin	1.0 Degree

REPLACEMENT BUSHINGS

PART NO.	Qty	DESCRIPTION	NOTES
QUANTITY PER SHOCK			
TW959	2	Suit Front Top Pin	Pin Style Bushing
ADJ00191	1	Suit Front Bottom Eying	Eying Bushing
ADJ00191	2	Suit Rear Top & Bottom Eying	Eying Bushing

Fitting sheet (located page 243) must be completed when suspension fitted. Failure to comply may affect warranty.



TOYOTA

LANDCRUISER - 70, 73, 74 SERIES

11/1984 - 1992



REAR SUSPENSION

ESTIMATED LIFT: 50mm

PART NO.	Qty	DESCRIPTION	NOTES
SHOCK ABSORBERS			
FC41350	2	Foam Cell Shock	OE Height
BM401350	2	40mm Adjustable Shock	
FC41377	2	Foam Cell Shock	50mm Lift
BM401377	2	40mm Adjustable Shock	
BMX1377/2	2	45mm Adjustable Shock	
TDR1377	2	'Ralph' Shock	
LEAF SPRINGS			
1 Left Hand Side and 1 Right Hand Side leaf spring pack should be ordered			
T44L-LH	1	0-300KG Load	50mm Lift Spring Left Hand Side
T44L-RH	1	0-300KG Load	50mm Lift Spring Right Hand Side
T44H-LH	1	CONSTANT 300KG Load	50mm Lift Spring Left Hand Side
T44H-RH	1	CONSTANT 300KG Load	50mm Lift Spring Right Hand Side
ADDITIONAL COMPONENTS			
TDUK-012	1	Urethane Shackle Bushing Kit	
TDUB-017	2	U-Bolt Kit	
TDGP-351	1	Greasable Pin Kit	
TDGS-357	1	Greasable Shackle Kit	

All prices exclude freight. Include only permanent accessories & weights when selecting springs. Towing weight is not included.



FRONT SUSPENSION

ESTIMATED LIFT: 50mm

PART NO.	Qty	DESCRIPTION	NOTES
SHOCK ABSORBERS			
FC41113B	2	Foam Cell Shock	Suit OE Height
FC41163B	2	Foam Cell Shock	50mm Lift - HZJ75 ONLY
FC41163	2	Foam Cell Shock	50mm Lift - Except HZJ75
BM401163	2	40mm Adjustable Shock	All Models
BMX1163/2	2	45mm Adjustable Shock	
TDR1163B	2	'Ralph' Shock	
LEAF SPRINGS			
T52	2	50mm Lift Spring	Petrol/Diesel/Bar
T52H	2	50mm Lift Spring	Petrol/Diesel/Bar/Winch
STEERING DAMPERS			
EXT5001	1	Heavy Duty Replacement Damper	Suit Power Steering
SS5001-P/S	1	Return To Centre Damper	
SV5001	1	9 Stage Adjustable Damper	
ADDITIONAL COMPONENTS			
TDUK-012	1	Urethane Shackle Bushing Kit	
TDUB-019	2	U-Bolt Kit	
TDGP-351	1	Greasable Pin Kit	
TDGS-357	1	Greasable Shackle Kit	
TAK-005	1	Offset King Pin	0.5 Degree
TAK-075	1	Offset King Pin	0.75 Degree
TAK-001	1	Offset King Pin	1.0 Degree

Fitting sheet (located page 243) must be completed when suspension fitted. Failure to comply may affect warranty.



REAR SUSPENSION

ESTIMATED LIFT: 50mm

PART NO.	Qty	DESCRIPTION	NOTES
SHOCK ABSORBERS			
FC41350	2	Foam Cell Shock	Suit OE Height
FC41377	2	Foam Cell Shock	
BM401377	2	40mm Adjustable Shock	Suit 50mm Lift
BMX1377/2	2	45mm Adjustable Shock	
TDR1377	2	'Ralph' Shock	
LEAF SPRINGS			
1 Left Hand Side and 1 Right Hand Side leaf spring pack should be ordered			
T51-LH	1	0-300KG Load	50mm Lift Spring Left Hand Side
T51-RH	1	0-300KG Load	50mm Lift Spring Right Hand Side
FS751M-LH	1	CONSTANT 300KG Load	50mm Lift Spring Left Hand Side
FS751M-RH	1	CONSTANT 300KG Load	50mm Lift Spring Right Hand Side
FS751HM-LH	1	CONSTANT 500KG Load	50mm Lift Spring Left Hand Side
FS751HM-RH	1	CONSTANT 500KG Load	50mm Lift Spring Right Hand Side
ADDITIONAL COMPONENTS			
TDUK-018	1	Urethane Shackle Bushing Kit	
TDUB-017	2	U-Bolt Kit	
TDSP-014	1	Brake Bias Bracket	Must be included in kit
TDGP-354	1	Greasable Pin Kit	
TDGS-357	1	Greasable Shackle Kit	
AIR ASSIST BAGS			
TDAA-115	1	Bellows Bag Kit	Suit 20mm To 75mm Lift
TDAA-121	1	Bellows Bag Kit	Suit Standard Height ONLY

REPLACEMENT BUSHINGS

PART NO.	Qty	DESCRIPTION	NOTES
QUANTITY PER SHOCK			
TW959	2	Suit Front Top Pin	Pin Style Bushing
ADJ00191	1	Suit Front Bottom Eying	Eying Bushing
ADJ00191	2	Suit Rear Top & Bottom Rear Eye	Eying Bushing



FRONT SUSPENSION

ESTIMATED LIFT: 50mm

PART NO.	Qty	DESCRIPTION	NOTES
SHOCK ABSORBERS			
FC41050	2	Foam Cell Shock	Up To 50mm Lift
BM401050	2	40mm Adjustable Shock	Up To 50mm Lift
BMX1050/2	2	45mm Adjustable Shock	50mm Lift
TDR1050	2	'Ralph' Shock	Up To 50mm Lift
COIL SPRINGS			
TDC950SL	1	OE Height Spring (Pair)	OE Height/Diesel/Bar
TDC950L	1	50mm Lift Spring (Pair)	Diesel/Bar
TDC950HL	1	50mm Lift Spring (Pair)	Diesel/Bar/Winch
STEERING DAMPERS			
EXT5004	1	Heavy Duty Replacement Damper	
SS5004-P/S	1	Return To Centre Damper	Suit Power Steering
SV5004	1	9 Stage Adjustable Damper	
CASTER CORRECTION			
TDUK-054/2	1	2 Degree Caster Correction	Optional Component
PANHARD RODS			
TDPR-015	1	Adjustable Panhard Rod	
ADDITIONAL COMPONENTS			
TDSP-013	1	Front Swaybar Spacer Kit	Fit If Tailshaft Contacts Swaybar
TAK-8005	1	Offset King Pin	0.5 Degree
TAK-8075	1	Offset King Pin	0.75 Degree
TAK-8001	1	Offset King Pin	1.0 Degree
TDUK-1961/30	1	Urethane Spring Spacer 30mm	

REPLACEMENT BUSHINGS

PART NO.	Qty	DESCRIPTION	NOTES
QUANTITY PER SHOCK			
TW959	4	Suit Front Top & Bottom	Pin Style Bushing
ADJ00191	2	Suit Rear Top & Bottom Rear Eye	Eyering Bushing

Fitting sheet (located page 243) must be completed when suspension fitted. Failure to comply may affect warranty.



TOYOTA

LANDCRUISER - 76 SERIES WAGON

2007 ON



REAR SUSPENSION

ESTIMATED LIFT: 50mm

PART NO.	Qty	DESCRIPTION	NOTES
SHOCK ABSORBERS			
FC41377	2	Foam Cell Shock	Up To 50mm Lift
BM401377	2	40mm Adjustable Shock	Up To 50mm Lift
BMX1377/2	2	45mm Adjustable Shock	50mm Lift
TDR1377	2	'Ralph' Shock	Up To 50mm Lift
LEAF SPRINGS			
FS761	2	0-300KG Load	50mm Lift Spring
FS761M	2	CONSTANT 300KG Load	50mm Lift Spring
FS761HM	2	CONSTANT 500KG Load	50mm Lift Spring
ADDITIONAL COMPONENTS			
TDUK-048	1	Urethane Bushing Kit (Pre 01/17)	Use Greasable Pins & Shackles
TDUK-048/14	1	Urethane Bushing Kit (Post 01/17)	
TDUB-024	2	U-Bolt Kit	
TDSP-014	1	Brake Bias Bracket	Suit Up To 01/2017
TDSP-015	1	Handbrake Relocation Bracket	Fit With BMX or TDR Shocks
TDGP-388	1	Greasable Pin Kit	
TDGS-387/18	1	Greasable Shackle Kit	
AIR ASSIST BAGS			
TDAA-115	1	Bellows Bag Kit	Suit 30mm To 75mm Lift
TDAA-121	1	Bellows Bag Kit	Suit Standard Height ONLY

All prices exclude freight. Include only permanent accessories & weights when selecting springs. Towing weight is not included.



FRONT SUSPENSION

ESTIMATED LIFT: 50mm

PART NO.	Qty	DESCRIPTION	NOTES
SHOCK ABSORBERS			
FC41113B	2	Foam Cell Shock	Suit OE Height
FC41163B	2	Foam Cell Shock	
BM401163	2	40mm Adjustable Shock	Suit 50mm Lift
BMX1163/2	2	45mm Adjustable Shock	
TDR1163B	2	'Ralph' Shock	
LEAF SPRINGS			
T52	2	50mm Lift Spring	Petrol/Diesel/Bar
T52H	2	50mm Lift Spring	Petrol/Diesel/Bar/Winch
STEERING DAMPERS			
EXT5001	1	Heavy Duty Replacement Damper	
SS5001-P/S	1	Return To Centre Damper	Suit Power Steering
SV5001	1	9 Stage Adjustable Damper	
ADDITIONAL COMPONENTS			
TDUK-012	1	Urethane Shackle Bushing Kit	
TDUB-019	2	U-Bolt Kit	
TDGP-351	1	Greasable Pin Kit	
TDGS-348	1	Greasable Shackle Kit	

Fitting sheet (located page 243) must be completed when suspension fitted. Failure to comply may affect warranty.



REAR SUSPENSION

ESTIMATED LIFT: 50mm

PART NO.	Qty	DESCRIPTION	NOTES
SHOCK ABSORBERS			
FC41377	2	Foam Cell Shock	Suit Up To 50mm Lift
BM401377	2	40mm Adjustable Shock	Suit Up To 50mm Lift
BMX1377/2	2	45mm Adjustable Shock	50mm Lift
TDR1377	2	'Ralph' Shock	Suit Up To 50mm Lift
LEAF SPRINGS			
FS761	2	0-300KG Load	50mm Lift Spring
FS761M	2	CONSTANT 300KG Load	50mm Lift Spring
ADDITIONAL COMPONENTS			
TDUK-018	1	Urethane Shackle Bushing Kit	
TDUB-017	2	U-Bolt Kit	
TDGP-354	1	Greasable Pin Kit	
TDGS-357	1	Greasable Shackle Kit	

REPLACEMENT BUSHINGS

PART NO.	Qty	DESCRIPTION	NOTES
QUANTITY PER SHOCK			
TW959	2	Suit Front Top Pin	Pin Style Bushing
ADJ00191	1	Suit Front Bottom Eying	Eying Bushing
ADJ00191	2	Suit Rear Top & Bottom Eying	Eying Bushing



FRONT SUSPENSION

ESTIMATED LIFT: 50mm

PART NO.	Qty	DESCRIPTION	NOTES
SHOCK ABSORBERS			
FC41254	2	Foam Cell Shock	Up To 50mm Lift
BM401254	2	40mm Adjustable Shock	Up To 50mm Lift
COIL SPRINGS			
TDC960L	1	50mm Lift Spring (Pair)	Diesel/Bar
TDC960HL	1	50mm Lift Spring (Pair)	Diesel/Bar/Winch
STEERING DAMPERS			
EXT5001	1	Heavy Duty Replacement Damper	
SS5001-P/S	1	Return To Centre Damper	
SV5001	1	9 Stage Adjustable Damper	

REAR SUSPENSION

PART NO.	Qty	DESCRIPTION	NOTES
SHOCK ABSORBERS			
FC41255	2	Foam Cell Shock	50mm Lift
BM401255	2	40mm Adjustable Shock	50mm Lift
COIL SPRINGS			
TDC961L	1	0-300KG Load (Pair)	50mm Lift Spring
TDC961HL	1	CONSTANT 300KG Load (Pair)	50mm Lift Spring

Fitting sheet (located page 243) must be completed when suspension fitted. Failure to comply may affect warranty.



THIS PAGE IS INTENTIONALLY BLANK

All prices exclude freight. Include only permanent accessories & weights when selecting springs. Towing weight is not included.





FRONT SUSPENSION

ESTIMATED LIFT: 50mm

PART NO.	Qty	DESCRIPTION	NOTES
SHOCK ABSORBERS			
FC41050	2	Foam Cell Shock	Up To 50mm Lift
BM401050	2	40mm Adjustable Shock	Up To 50mm Lift
BMX1050/2	2	45mm Adjustable Shock	50mm Lift
TDR1050	2	'Ralph' Shock	Up To 50mm Lift
COIL SPRINGS			
TDC950SL	1	OE Height Spring (Pair)	Petrol/Diesel/Bar - OE Height
TDC950L	1	50mm Lift Spring (Pair)	Petrol/Diesel/Bar
TDC950HL	1	50mm Lift Spring (Pair)	Petrol/Diesel/Bar/Winch
STEERING DAMPERS			
EXT5001	1	Heavy Duty Replacement Damper	
SS5001-P/S	1	Return To Centre Damper	Suit 6 Cylinder Models
SV5001	1	9 Stage Adjustable Damper	
EXT5004	1	Heavy Duty Replacement Damper	
SS5004-P/S	1	Return To Centre Damper	Suit V8 Models
SV5004	1	9 Stage Adjustable Damper	
CASTER CORRECTION			
TDUK-054/2	1	2 Degre Caster Correction	
PANHARD RODS			
TDPR-079	1	Adjustable Panhard Rod	Suit 6 Cylinder Engine
TDPR-015	1	Adjustable Panhard Rod	Suit V8 - Up To 08/2016 ONLY
TDPR-006	1	Adjustable Panhard Rod	Suit V8 - 09/2016 On
TDPR-019	1	Adjustable Panhard Rod	6 Cylinder LHD ONLY
TDPR-025	1	Adjustable Panhard Rod	8 Cylinder LHD ONLY
ADDITIONAL COMPONENTS			
TDSB-007	1	33mm Sway Bar	To Fit V8 vehicles only
TDSB-011	1	33mm Sway Bar	To Fit V6 vehicles only
TDSP-013	1	Front Swaybar Spacer Kit	Fit If Tailshaft Contacts Swaybar
TDUK-1961/30	1	Urethane Spring Spacer 30mm	
TDUK-043	1	Panhard Rod Bushings	Suit All Panhard Rods
TAK-8005	1	Offset King Pin	0.5 Degree
TAK-8075	1	Offset King Pin	0.75 Degree
TAK-8001	1	Offset King Pin	1.0 Degree

Fitting sheet (located page 243) must be completed when suspension fitted. Failure to comply may affect warranty.



REAR SUSPENSION

ESTIMATED LIFT: 50mm

PART NO.	Qty	DESCRIPTION	NOTES
SHOCK ABSORBERS			
FC41377	2	Foam Cell Shock	Up To 50mm Lift
BM401377	2	40mm Adjustable Shock	Up To 50mm Lift
BMX1377/2	2	45mm Adjustable Shock	50mm Lift
TDR1377	2	'Ralph' Shock	Up To 50mm Lift
LEAF SPRINGS			
Where stated 1 Left Hand Side & 1 Right Hand Side leaf spring pack should be ordered If FS781XHD springs selected, then select 1 x TDSB-012 as well			
BP-019	2	0-200KG Load	50mm Lift Spring
FS781-LH	1	CONSTANT 400KG Load	50mm Lift Spring Left Hand Side
FS781-RH	1	CONSTANT 400KG Load	50mm Lift Spring Right Hand Side
FS781HM-LH	1	CONSTANT 600KG Load	50mm Lift Spring Left Hand Side
FS781HM-RH	1	CONSTANT 600KG Load	50mm Lift Spring Right Hand Side
FS781XHD-LH	1	CONSTANT 900KG Load	50mm Lift Spring Left Hand Side
FS781XHD-RH	1	CONSTANT 900KG Load	50mm Lift Spring Right Hand Side
ADDITIONAL COMPONENTS			
TDSB-008	1	Heavy Duty Sway Bar	Fit With CONSTANT 900KG Spring
TDSB-012	1	Heavy Duty Sway Bar	Fit With CONSTANT 900KG Spring - 5 Star ANCAP ONLY
TDUK-033	1	Replacement Bush for Sway Bar	
TDUK-048	1	Urethane Shackle Bushing Kit	Suit V8 & With Greasable Pins & Shackles
TDUK-048/14	1	Urethane Shackle Bushing Kit	Suit Ute Before 06/2009 Suit standard pins & shackles ONLY
TDUK-048/18	1	Urethane Shackle Bushing Kit	Suit T/Carrier Before 06/2009 Suit standard pins & shackles ONLY
TDUB-024	2	U-Bolt Kit (230mm Long)	
TDUB-038	2	U-Bolt Kit (290mm Long)	Use With FS781XHD
TDSP-014	1	Brake Bias Bracket	Not Required AFTER 01/2017
TDSP-015	1	Handbrake Relocation Bracket	Fit With BMX Or TDR Shock
TDGP-388	1	Greasable Pin Kit	
TDGS-387/18	1	Greasable Shackle Kit	
AIR ASSIST BAGS			
TDAA-115	1	Bellows Bag Kit	Suit 30mm to 75mm Lift
TDAA-121	1	Bellows Bag Kit	Suit Standard Height ONLY

PLEASE NOTE:

Include weight of tray when calculating **CONSTANT** Load



FRONT SUSPENSION

ESTIMATED LIFT: 50mm

PART NO.	Qty	DESCRIPTION	NOTES
SHOCK ABSORBERS			
FC41050	2	Foam Cell Shock	Up To 50mm Lift
BM401050	2	40mm Adjustable Shock	Up To 50mm Lift
BMX1050/2	2	45mm Adjustable Shock	50mm Lift
TDR1050	2	'Ralph' Shock	Up To 50mm Lift
COIL SPRINGS			
TDC950SL	1	OE Height Spring (Pair)	Diesel/Bar - OE Height ONLY
TDC950L	1	50mm Lift Spring (Pair)	Diesel/Bar
TDC950HL	1	50mm Lift Spring (Pair)	Diesel/Bar/Winch
STEERING DAMPERS			
EXT5004	1	Heavy Duty Replacement Damper	Suit V8 Models
SS5004-P/S	1	Return To Centre Damper	
SV5004	1	9 Stage Adjustable Damper	
CASTER CORRECTION			
TDUK-054/2	1	2 Degree Caster Correction	
PANHARD RODS			
TDPR-015	1	Adjustable Panhard Rod	
TDPR-025	1	Adjustable Panhard Rod	V8 LHD ONLY
ADDITIONAL COMPONENTS			
TDSB-007	1	33mm Sway Bar	To Fit V8 vehicles only
TDSP-013	1	Front Swaybar Spacer Kit	Fit If Tailshaft Contacts Swaybar
TDUK-1961/30	1	Urethane Spring Spacer 30mm	
TAK-8005	1	Offset King Pin	0.5 Degree
TAK-8075	1	Offset King Pin	0.75 Degree
TAK-8001	1	Offset King Pin	1.0 Degree

PLEASE NOTE:

OE vehicle weight based on cab chassis (excludes tub-tray)



REAR SUSPENSION

ESTIMATED LIFT: 50mm

PART NO.	Qty	DESCRIPTION	NOTES
SHOCK ABSORBERS			
FC41377	2	Foam Cell Shock	Up To 50mm Lift
BM401377	2	40mm Adjustable Shock	Up To 50mm Lift
BMX1377/2	2	45mm Adjustable Shock	50mm Lift
TDR1377	2	'Ralph' Shock	Up To 50mm Lift
LEAF SPRINGS			
1 Left Hand Side and 1 Right Hand Side leaf spring pack should be ordered			
FS781-LH	1	CONSTANT 300KG Load	50mm Lift Spring Left Hand Side
FS781-RH	1	CONSTANT 300KG Load	50mm Lift Spring Right Hand Side
FS781HM-LH	1	CONSTANT 500KG Load	50mm Lift Spring Left Hand Side
FS781HM-RH	1	CONSTANT 500KG Load	50mm Lift Spring Right Hand Side
FS781XHD-LH	1	CONSTANT 800KG Load	50mm Lift Spring Left Hand Side Fit TDSB-008
FS781XHD-RH	1	CONSTANT 800KG Load	50mm Lift Spring Right Hand Side Fit TDSB-008
ADDITIONAL COMPONENTS			
TDSB-008	1	Heavy Duty Sway Bar	Fit with CONSTANT 800KG Spring
TDUK-033	1	Replacement Bush for Sway Bar	
TDUK-048	1	Urethane Shackle Bushing Kit	
TDUB-024	2	U-Bolt Kit (230mm Long)	
TDUB-038	2	U-Bolt Kit (290mm Long)	Use With FS781XHD
TDSP-014	1	Brake Bias Bracket	Not Required AFTER 01/2017
TDSP-015	1	Handbrake Relocation Bracket	Fit With BMX Or TDR Shock
TDGP-388	1	Greasable Pin Kit	
TDGS-387/18	1	Greasable Shackle Kit	
AIR ASSIST BAGS			
TDAA-115	1	Bellows Bag Kit	Suit Up To 75mm Lift
TDAA-121	1	Bellows Bag Kit	Suit Standard Height ONLY

REPLACEMENT BUSHINGS

PART NO.	Qty	DESCRIPTION	NOTES
QUANTITY PER SHOCK			
TW957	4	Suit Front Top & Bottom Pin	Pin Style Bushing
ADJ00191	2	Suit Rear Top & Bottom Eying	Eying Bushing



FRONT SUSPENSION

ESTIMATED LIFT: 50mm

PART NO.	Qty	DESCRIPTION	NOTES
SHOCK ABSORBERS			
FC41002	2	Foam Cell Shock	Suit Up To 50mm Lift
BM401002	2	40mm Adjustable Shock	Suit Up To 50mm Lift
BMX1002/2	2	45mm Adjustable Shock	50mm Lift ONLY
TDR1002B	2	'Ralph' Shock	Suit Up To 50mm Lift
COIL SPRINGS			
TDC943S	1	Petrol/Alloy Bar (Pair)	
TDC948L	1	Diesel/Bar (Pair)	03/1990-1991 80 Series Suit 25mm Lift
TDC948HL	1	Petrol/Diesel/Bar/Winch (Pair)	
TDC943	1	Petrol/Diesel/Bar (Pair)	03/1990-1991 80 Series Suit 50mm Lift
TDC943H	1	Petrol/Diesel/Bar/Winch (Pair)	
TDC948SL	1	Petrol/Alloy Bar (Pair)	09/1991-1998 80 Series
TDC948HSL	1	Petrol/Diesel/Bar/Winch (Pair)	03/1998-2007 105 Series Suit 25mm Lift
TDC948L	1	Petrol/Diesel/Bar/Winch/D. Battery (Pair)	
TDC943S	1	80 Series ONLY No Bar (Pair)	
TDC948L	1	Petrol/Diesel/Bar (Pair)	09/1991-1998 80 Series
TDC948HL	1	Petrol/Diesel/Bar/Winch (Pair)	03/1998-2007 105 Series Suit 50mm Lift
TDC943H	1	Petrol/Diesel/Bar/Winch/D. Battery (Pair)	
STEERING DAMPERS			
EXT5001	1	Heavy Duty Replacement Damper	
SS5001-P/S	1	Return To Centre Damper	
SV5001	1	9 Stage Adjustable Damper	
CASTER CORRECTION			
TDUK-054/2	1	2 Degree Caster Correction Bush	
PANHARD RODS			
TDPR-006	1	Adjustable Panhard Rod	
TDPR-001	1	Adjustable Panhard Rod	LHD ONLY
ADDITIONAL COMPONENTS			
TDUK-044	1	Front Radius Rod To Chassis	Bush Kit
TDUK-050	1	Front Radius Rod To Diff	Bush Kit
TDUK-043	1	Panhard Rod Bushing Kit	
TDUK-1725/20	1	Urethane Spring Spacer Kit 20mm	1 Kit Required Per Coil
TDUK-1725/30	1	Urethane Spring Spacer 30mm	1 Kit Required Per Coil
TAK-8005	1	Offset Kingpin	0.5 Degree
TAK-8075	1	Offset Kingpin	0.75 Degree
TAK-8001	1	Offset Kingpin	1.0 Degree

Fitting sheet (located page 243) must be completed when suspension fitted. Failure to comply may affect warranty.



TOYOTA

LANDCRUISER - 80 & 105 SERIES 2" 05/1990 - 2007



REAR SUSPENSION

ESTIMATED LIFT: 50mm

PART NO.	Qty	DESCRIPTION	NOTES
SHOCK ABSORBERS			
FC41111	2	Foam Cell Shock	Suit Up To 50mm Lift
BM401111	2	40mm Adjustable Shock	Suit Up To 50mm Lift
BMX1111/2	2	45mm Adjustable Shock	50mm Lift ONLY
TDR1111	2	'Ralph' Shock	Suit Up To 50mm Lift
COIL SPRINGS			
TDC945S	1	0-300KG Load (Pair)	
TDC949L	1	CONSTANT 300KG Load (Pair)	03/1990-1991 80 Series 25mm Lift
TDC949HL	1	CONSTANT 500KG Load (Pair)	
TDC945	1	0-300KG Load (Pair)	03/1990-1991 80 Series
TDC945H	1	CONSTANT 300KG Load (Pair)	50mm Lift
TDC949SL	1	0-300KG Load (Pair)	09/1991-1998 80 Series
TDC949HSL	1	CONSTANT 300KG Load (Pair)	03/1998-2007 105 Series
TDC949L	1	CONSTANT 500KG Load (Pair)	25mm Lift
TDC945S	1	No Load (Pair)	
TDC949L	1	0-300KG Load (Pair)	09/1991-1998 80 Series
TDC949HL	1	CONSTANT 300KG Load (Pair)	03/1998-2007 105 Series
TDC945H	1	CONSTANT 500KG Load (Pair)	50mm Lift
PANHARD RODS			
TDPR-007	1	Adjustable Panhard Rod	
ADDITIONAL COMPONENTS			
TDUK-045	1	Trailing Arm Bushing Kit (Upper)	
TDUK-046	1	Trailing Arm Bushing Kit (Lower)	
TDUK-047	1	Panhard Road Bush Kit	
TDUK-1724/15	1	Urethane Spring Spacer 15mm	1 Kit Required Per Coil As Required
TDUK-1724/30	1	Urethane Spring Spacer 30mm	1 Kit Required Per Coil As Required
AIR ASSIST BAGS			
TDAA-021	1	Coil Insert Bag Kit	Suit Standard Height ONLY
TDAA-010	1	Coil Insert Bag Kit	Suit Up To 25mm Lift
TDAA-011	1	Coil Insert Bag Kit	Suit Up To 50mm Lift

REPLACEMENT BUSHINGS

PART NO.	Qty	DESCRIPTION	NOTES
QUANTITY PER SHOCK			
TW957	4	Suit Front Top & Bottom Pin	Pin Style Bushing
TW957	2	Suit Rear Top Pin	Pin Style Bushing
415024	1	Suit Rear Bottom Eying	Eying Bushing

All prices exclude freight. Include only permanent accessories & weights when selecting springs. Towing weight is not included.



FRONT SUSPENSION

ESTIMATED LIFT: 75mm

PART NO.	Qty	DESCRIPTION	NOTES
SHOCK ABSORBERS			
FC41002	2	Foam Cell Shock	
BM401002	2	40mm Adjustable Shock	Suit 75mm Lift
BMX1002/2	2	45mm Adjustabe Shock	
TDR1002B	2	'Ralph' Shock	
COIL SPRINGS			
TDC943	1	75mm Lift Spring (Pair)	Petrol/Alloy Bar
TDC948/3	1	75mm Lift Spring (Pair)	Diesel/Bar
TDC943H	1	75mm Lift Spring (Pair)	Petrol/Diesel/Bar/Winch
STEERING DAMPERS			
EXT5001	1	Heavy Duty Replacement Damper	
SS5001-P/S	1	Return To Centre Damper	
SV5001	1	9 Stage Adjustable Damper	
CASTER CORRECTION			
TDUK-054/2	1	2 Degree Caster Correction Bush	
PANHARD RODS			
TDPR-006	1	Adjustable Panhard Rod	
TDPR-001	1	Adjustable Panhard Rod	LHD ONLY
ADDITIONAL COMPONENTS			
TDUK-044	1	Front Radius Rod To Chassis	Bush Kit
TDUK-050	1	Front Radius Rod To Diff	Bush Kit
TDUK-043	1	Panhard Rod Bushing Kit	
TDUK-1725/20	1	Urethane Spring Spacer 20mm	1 Kit Required Per Coil As Required
TDUK-1725/30	1	Urethane Spring Spacer 30mm	1 Kit Required Per Coil As Required
TAK-8005	1	Offset Kingspin	0.5 Degree
TAK-8075	1	Offset Kingpin	0.75 Degree
TAK-8001	1	Offset Kingpin	1.0 Degree
BRAKE HOSE KITS			
TDBH-003	1	Rubber Brake Hose Kit	80 & 105 Series NON ABS
TDBH-197	1	Braided Brake Hose Kit	
TDBH-300	1	Rubber Brake Hose Kit	80 Series ABS
TDBH-200	1	Braided Brake Hose Kit	
TDBH-398	1	Rubber Brake Hose Kit	105 Series ABS
TDBH-198	1	Braided Brake Hose Kit	

Fitting sheet (located page 243) must be completed when suspension fitted. Failure to comply may affect warranty.



TOYOTA

LANDCRUISER - 80 & 105 SERIES 3" 05/1990 - 2007



REAR SUSPENSION

ESTIMATED LIFT: 75mm

PART NO.	Qty	DESCRIPTION	NOTES
SHOCK ABSORBERS			
FC41111	2	Foam Cell Shock	
BM401111	2	40mm Adjustable Shock	Suit 75mm Lift
BMX1111/2	2	45mm Adjustable Shock	
TDR1111	2	'Ralph' Shock	
COIL SPRINGS			
TDC949/3	1	0-300KG Load (Pair)	
TDC945	1	CONSTANT 300KG Load (Pair)	75mm Lift Spring
TDC945H	1	CONSTANT 500KG Load (Pair)	
PANHARD RODS			
TDPR-007	1	Adjustable Panhard Rod	
ADDITIONAL COMPONENTS			
TDUK-045	1	Trailing Arm Bushing Kit (Upper)	
TDUK-046	1	Trailing Arm Bushing Kit (Lower)	
TDUK-047	1	Panhard Rod Bushing Kit	
TDUK-1724/15	1	Urethane Spring Spacer 15mm	1 Kit Required Per Coil As Required
TDUK-1724/30	1	Urethane Spring Spacer 30mm	1 Kit Required Per Coil As Required

REPLACEMENT BUSHINGS - Refer page 215

Please select components needed as outlined in the table below

COMPLETE KIT PRICE REFERENCE

SHOCK CHOICE	SPRING CHOICE	CONTENTS
41mm Foam Cell	\$280 (F) \$360 (R)	 <p>Includes: 4 x Coil Springs 4 x Shocks 1 x Caster Correction Kit 2 x Panhard Rods 1 x Brake Hose Kit (TDBH-003)</p>
	\$280 (F) \$340 (R)	
	\$280 (F) \$404 (R)	
40mm 9 Stage Adjustable	\$280 (F) \$360 (R)	
	\$280 (F) \$340 (R)	
	\$280 (F) \$404 (R)	
45mm 9 Stage Adjustable	\$280 (F) \$360 (R)	
	\$280 (F) \$340 (R)	
	\$280 (F) \$404 (R)	
53mm Ralph	\$280 (F) \$360 (R)	
	\$280 (F) \$340 (R)	
	\$280 (F) \$404 (R)	

All prices exclude freight. Include only permanent accessories & weights when selecting springs. Towing weight is not included.



FRONT SUSPENSION

ESTIMATED LIFT: 100mm

PART NO.	Qty	DESCRIPTION	NOTES
SHOCK ABSORBERS			
FC41002/4	2	Foam Cell Shock	100mm Lift
BMX1002/4	2	45mm Adjustable Shock	100mm Lift
COIL SPRINGS			
TDC948/4	1	100mm Lift Spring (Pair)	Petrol/Diesel/Bar
TDC948/4H	1	100mm Lift Spring (Pair)	Petrol/Diesel/Bar/Winch
STEERING DAMPERS			
SS5001-XHD	1	Return To Centre Damper	Suit RHD
SV5001/4	1	9 Stage Adjustable Damper	
SS5002-XHD	1	Return To Center Damper	Suit LHD
SV5002/4	1	9 Stage Adjustable Damper	
CASTER CORRECTION			
TDUK-054/3	1	3 Degree Caster Correction Bush	
PANHARD RODS			
TDPR-006	1	Adjustable Panhard Rod	RHD
TDPR-001	1	Adjustable Panhard Rod	LHD
ADDITIONAL COMPONENTS			
TDUK-044	1	Front Radius Rod To Chassis	Bush Kit
TDUK-050	1	Front Radius Rod To Diff	Bush Kit
TDUK-043	1	Panhard Rod Bushing Kit	
TDUK-1725/20	1	Urethane Spring Spacer 20mm	1 Kit Required Per Coil As Required
TDUK-1725/30	1	Urethane Spring Spacer 30mm	1 Kit Required Per Coil As Required
TAK-8005	1	Offset Kingspin	0.5 Degree
TAK-8075	1	Offset Kingpin	0.75 Degree
TAK-8001	1	Offset Kingpin	1.0 Degree
BRAKE HOSE KITS			
TDBH-003	1	Rubber Brake Hose Kit	80 & 105 Series NON ABS
TDBH-197	1	Braided Brake Hose Kit	
TDBH-300	1	Rubber Brake Hose Kit	80 Series ABS
TDBH-200	1	Braided Brake Hose Kit	
TDBH-398	1	Rubber Brake Hose Kit	105 Series ABS
TDBH-198	1	Braided Brake Hose Kit	

Fitting sheet (located page 243) must be completed when suspension fitted. Failure to comply may affect warranty.



REAR SUSPENSION

ESTIMATED LIFT: 100mm

PART NO.	Qty	DESCRIPTION	NOTES
SHOCK ABSORBERS			
FC41111/4	2	Foam Cell Shock	100mm Lift
BMX1111/4	2	45mm Adjustable Shock	100mm Lift
COIL SPRINGS			
TDC949/4	1	0-300KG Load (Pair)	100mm Lift
TDC949/4H	1	CONSTANT 300KG Load (Pair)	100mm Lift
PANHARD RODS			
TDPR-007	1	Adjustable Panhard Rod	
ADDITIONAL COMPONENTS			
TDUK-045	1	Trailing Arm Bushing Kit (Upper)	
TDUK-046	1	Trailing Arm Bushing Kit (Lower)	
TDUK-047	1	Panhard Rod Bushing Kit	
TDUK-1724/15	1	Urethane Spring Spacer 15mm	1 Kit Required Per Coil As Required
TDUK-1724/30	1	Urethane Spring Spacer 30mm	1 Kit Required Per Coil As Required

REPLACEMENT BUSHINGS - Refer page 215

Please select components needed as outlined in the table below

COMPLETE KIT PRICE REFERENCE

SHOCK CHOICE	SPRING CHOICE	CONTENTS
41mm Foam Cell	Up To Bar Front 0-300KG Rear	 <p>Includes: 4 x Coil Springs 4 x Shocks 1 x Caster Correction Kit 2 x Panhard Rods 1 x Brake Hose Kit (TDBH-003)</p>
	Bar & Winch Front 0-300KG Rear	
40mm 9 Stage Adjustable	Up To Bar Front 0-300KG Rear	
	Bar & Winch Front 0-300KG Rear	



FRONT SUSPENSION

ESTIMATED LIFT: 125mm

PART NO.	Qty	DESCRIPTION	NOTES
SHOCK ABSORBERS			
BMX1002/6	2	45mm Adjustable Shock	125mm Lift
COIL SPRINGS			
TDC948/5	1	125mm Lift Spring (Pair)	Petrol/Diesel/Bar
TDC948/5H	1	125mm Lift Spring (Pair)	Petrol/Diesel/Bar/Winch
STEERING DAMPERS			
SS5001-XHD	1	Return To Centre Damper	RHD
SV5001/4	1	9 Stage Adjustable Damper	
SS5002-XHD	1	Return To Centre Damper	LHD
SV5002/4	1	9 Stage Adjustable Damper	
CASTER CORRECTION			
TDCP-006	1	5 Degree Caster Correction Plate	
PANHARD RODS			
TDPR-006	1	Adjustable Panhard Rod	RHD
TDPR-001	1	Adjustable Panhard Rod	LHD
ADDITIONAL COMPONENTS			
TDUK-044	1	Front Radius Rod To Chassis	Bush Kit
TDUK-050	1	Front Radius Rod To Diff	Bush Kit
TDUK-043	1	Panhard Rod Bushing Kit	
TDUK-1725/20	1	Urethane Spring Spacer 20mm	1 Kit Required Per Coil As Required
TDUK-1725/30	1	Urethane Spring Spacer 30mm	1 Kit Required Per Coil As Required
TAK-8005	1	Offset Kingspin	0.5 Degree
TAK-8075	1	Offset Kingpin	0.75 Degree
TAK-8001	1	Offset Kingpin	1.0 Degree
BRAKE HOSE KITS			
TDBH-003	1	Rubber Brake Hose Kit	80 & 105 Series NON ABS
TDBH-197	1	Braided Brake Hose Kit	
TDBH-300	1	Rubber Brake Hose Kit	80 Series ABS
TDBH-200	1	Braided Brake Hose Kit	
TDBH-398	1	Rubber Brake Hose Kit	105 Series ABS
TDBH-198	1	Braided Brake Hose Kit	

Fitting sheet (located page 243) must be completed when suspension fitted. Failure to comply may affect warranty.



REAR SUSPENSION

ESTIMATED LIFT: 125mm

PART NO.	Qty	DESCRIPTION	NOTES
SHOCK ABSORBERS			
BMX1111/6	2	45mm Adjustable Shock	125mm Lift
COIL SPRINGS			
TDC949/5	1	0-300KG Load (Pair)	125mm Lift Spring
TDC949/5H	1	CONSTANT 300KG Load (Pair)	125mm Lift Spring
PANHARD RODS			
TDPR-007	1	Adjustable Panhard Rod	
ADDITIONAL COMPONENTS			
TDUK-045	1	Trailing Arm Bushing Kit (Upper)	
TDUK-046	1	Trailing Arm Bushing Kit (Lower)	
TDUK-047	1	Panhard Rod Bushing Kit	
TDUK-1724/15	1	Urethane Spring Spacer 15mm	1 Kit Required Per Coil As Required
TDUK-1724/30	1	Urethane Spring Spacer 30mm	1 Kit Required Per Coil As Required

REPLACEMENT BUSHINGS - Refer page 215

Please select components needed as outlined in the table below

COMPLETE KIT PRICE REFERENCE

SHOCK CHOICE	SPRING CHOICE	CONTENTS
45mm 9 Stage Adjustable Shocks	Up To Bar Front 0-300KG Rear	 <p>Includes: 4 x Coil Springs 4 x Shocks 1 x Caster Correction Kit 2 x Panhard Rods 1 x Brake Hose Kit (TDBH-003)</p>
	Up To Bar Front 300KG Rear	
	Bar & Winch Front 0-300KG Rear	
	Bar & Winch Front 300KG Rear	



FRONT SUSPENSION

ESTIMATED LIFT: 150mm

PART NO.	Qty	DESCRIPTION	NOTES
SHOCK ABSORBERS			
BMX1002/6	2	45mm Adjustable Shock	150mm Lift
COIL SPRINGS			
TDC948/6	1	150mm Lift Spring (Pair)	Petrol/Diesel/Bar
TDC948/6H	1	150mm Lift Spring (Pair)	Petrol/Diesel/Bar/Winch
CASTER CORRECTION			
TDCP-006	1	5 Degree Caster Correction Plate	
PANHARD RODS			
TDPR-006	1	Adjustable Panhard Rod	RHD
TDPR-001	1	Adjustable Panhard Rod	LHD
ADDITIONAL COMPONENTS			
TDUK-044	1	Front Radius Rod To Chassis	Bush Kit
TDUK-050	1	Front Radius Rod To Diff	Bush Kit
TDUK-043	1	Panhard Rod Bushing Kit	
TDUK-1725/20	1	Urethane Spring Spacer 20mm	1 Kit Required Per Coil As Required
TDUK-1725/30	1	Urethane Spring Spacer 30mm	1 Kit Required Per Coil As Required
TAK-8005	1	Offset Kingspin	0.5 Degree
TAK-8075	1	Offset Kingpin	0.75 Degree
TAK-8001	1	Offset Kingpin	1.0 Degree
BRAKE HOSE KITS			
TDBH-003	1	Rubber Brake Hose Kit	80 & 105 Series NON ABS
TDBH-197	1	Braided Brake Hose Kit	
TDBH-300	1	Rubber Brake Hose Kit	80 Series ABS
TDBH-200	1	Braided Brake Hose Kit	
TDBH-398	1	Rubber Brake Hose Kit	105 Series ABS
TDBH-198	1	Braided Brake Hose Kit	

Fitting sheet (located page 243) must be completed when suspension fitted. Failure to comply may affect warranty.



REAR SUSPENSION

ESTIMATED LIFT: 150mm

PART NO.	Qty	DESCRIPTION	NOTES
SHOCK ABSORBERS			
BMX1111/6	2	45mm Adjustable Shock	150mm Lift
COIL SPRINGS			
TDC949/6	1	0-300KG Load (Pair)	150mm Lift Spring
TDC949/6H	1	CONSTANT 300KG Load (Pair)	150mm Lift Spring
PANHARD RODS			
TDPR-007	1	Adjustable Panhard Rod	
ADDITIONAL COMPONENTS			
TDUK-045	1	Trailing Arm Bushing Kit (Upper)	
TDUK-046	1	Trailing Arm Bushing Kit (Lower)	
TDUK-047	1	Panhard Rod Bushing Kit	
TDUK-1724/15	1	Urethane Spring Spacer 15mm	1 Kit Required Per Coil As Required
TDUK-1724/30	1	Urethane Spring Spacer 30mm	1 Kit Required Per Coil As Required

REPLACEMENT BUSHINGS - Refer page 215

Please select components needed as outlined in the table below

COMPLETE KIT PRICE REFERENCE

SHOCK CHOICE	SPRING CHOICE	CONTENTS
45mm 9 Stage Adjustable Shocks	ANY COIL (RHD ONLY)	 <p>Includes: 4 x Coil Springs 4 x Shocks 1 x Caster Correction Kit 2 x Panhard Rods 1 x Brake Hose Kit (TDBH-003)</p>



FRONT SUSPENSION

ESTIMATED LIFT: 25mm

PART NO.	Qty	DESCRIPTION	NOTES
SHOCK ABSORBERS			
FC41103	2	Foam Cell Shock	Suit Up To 25mm Lift
TDR1103	2	'Ralph' Shock	Suit Up To 25mm Lift
TORSION BARS			
4WTB-1600	1	Replacement Torsion Bars	32mm/1160mm (PETROL)
4WTB-1610	1	Replacement Torsion Bars	32mm/1210mm (DIESEL)
4WTB-1610/BKT	1	Torsion Bar Strengthening Kit	Required With Torsion Bars
RIM TO GUARD MEASUREMENT (Bottom of Rim To Guard)			
For 16" Rim	740mm	Torsion Bars must only be adjusted so that the rim to guard measurements are not more that the measurements listed here. Lifting the vehicle higher than the specified measurement will result in the failure os front end components, including shock failure.	
For 17" Rim	753mm		

REPLACEMENT BUSHINGS

PART NO.	Qty	DESCRIPTION	NOTES
QUANTITY PER SHOCK			
ADJ300/40A	1	Suit Front Bottom Eying	Suit TDR Shock ONLY
TW040-14	1	Suit Front Bottom Eying	Suit FC Shock ONLY
404454B	2	Suit Front Top Pin	Pin Type Bushing
404454B	1	Suit Rear Top Of Top Pin	Pin Type Bushing
404454A	1	Suit Rear Bottom Of Top Pin	Pin Type Bushing
415024	1	Suit Rear Bottom Eying	Eying Bushing

Fitting sheet (located page 243) must be completed when suspension fitted. Failure to comply may affect warranty.



TOYOTA

LANDCRUISER - 100 SERIES (IFS)

1998 - 2007



REAR SUSPENSION

ESTIMATED LIFT: 25mm

PART NO.	Qty	DESCRIPTION	NOTES
SHOCK ABSORBERS			
FC41114	2	Foam Cell Shock	
BM401114	2	40mm Adjustable Shock	Suit Up To 25mm Lift
BMX1114/2	2	45mm Adjustable Shock	
TDR1114	2	'Ralph' Shock	
COIL SPRINGS			
TDC949HSL	1	0-300KG Load (Pair)	OE Height
TDC949L	1	0-300KG Load (Pair)	25mm Lift
TDC949HL	1	CONSTANT 300KG Load (Pair)	25mm Lift
PANHARD RODS			
TDPR-003	1	Adjustable Panhard Rod	
ADDITIONAL COMPONENTS			
TDUK-025	1	Trailing Arm Bush Kit	1 Kit Required (Upper)
TDUK-026	1	Trailing Arm Bush Kit	1 Kit Required (Lower)
TDUK-1724/15	1	Urethane Spring Spacer 15mm	1 Kit Required Per Coil As Required
TDUK-1724/30	1	Urethane Spring Spacer 30mm	1 Kit Required Per Coil As Required
AIR ASSIST BAGS			
TDAA-021	1	Coil Insert Bag Kit	Suit Standard Height ONLY
TDAA-010	1	Coil Insert Bag Kit	Suit Up To 25mm Lift
TDAA-011	1	Coil Insert Bag Kit	Suit Up To 50mm Lift

All prices exclude freight. Include only permanent accessories & weights when selecting springs. Towing weight is not included.



FRONT SUSPENSION

ESTIMATED LIFT: 40mm

PART NO.	Qty	DESCRIPTION	NOTES
SHOCK ABSORBERS			
FC404900	2	Foam Cell Strut	
BM404900	2	40mm Adjustable Strut	9 Stage Adjustable
BMX454900	2	45mm Adjustable Strut	Does NOT Suit Factory Coils
TDR4900	2	'Ralph' Shock	Does NOT Suit Factory Coils
COIL SPRINGS			
TDC930SL	1	OE Height (Pair)	OE Height Spring
TDC930HSL	1	OE Height (Pair)	OE Height/Bar/Winch
TDC930L	1	40mm Lift Spring (Pair)	Bar - Excluding Sahara
TDC930HL	1	40mm Lift Spring (Pair)	Bar/Winch
TDC932SL	1	25mm Lift - BMX & RALPH (Pair)	25mm Bar - BMX & RALPH
TDC932L	1	40mm Lift - BMX & RALPH (Pair)	Bar - OE Height Sahara
TDC932HL	1	40mm Lift - BMX & RALPH (Pair)	Bar/Winch
COMPLETE STRUT ASSEMBLY			
TOY-200/11	2	BM404900/TDC930SL	Petrol/Diesel/Bar (OE HEIGHT)
TOY-200/01	2	BM404900/TDC930L	Petrol/Diesel/Bar
TOY-200/02	2	BM404900/TDC930HL	Petrol/Diesel/Bar/Winch
TOY-200/10	2	FC404900/TDC930SL	Petrol/Diesel/Bar (OE HEIGHT)
TOY-200/15	2	FC404900/TDC930HSL	Petrol/Diesel/Bar/Winch (OE HEIGHT)
TOY-200/04	2	FC404900/TDC930L	Petrol/Diesel/Bar
TOY-200/05	2	FC404900/TDC930HL	Petrol/Diesel/Bar/Winch
TOY-200/07	2	BMX454900/TDC932L	Petrol/Diesel/Bar
TOY-200/08	2	BMX454900/TDC932HL	Petrol/Diesel/Bar/Winch
TOY-200/18	2	BMX454900/TDC932SL	Petrol/Diesel/Bar - 25mm Lift BMX
TOY-200/16	2	TDR4900/TDC932L	Petrol/Diesel/Bar
TOY-200/17	2	TDR4900/TDC932HL	Petrol/Diesel/Bar/Winch
TOY-200/12	2	TDR4900/TDC932SL	Petrol/Diesel/Bar - 25mm Lift Ralph
ADDITIONAL COMPONENTS			
TOY-1020	2	Strut Top	Replacement Strut Top
TDSB-005	1	Sway Bar (38mm)	
TDUK-087	1	Rear Coil Spacer	Suit KDSS Models
TDCA-004	1	Upper Control Arms (Pair)	Suit Up To 50mm Lift
TDSK-005	1	Bush Kit for TDCA-004	Replacement Bush Kit
TDSK-006	1	Ball Joint Kit for TDCA-004	Replacement Ball Joint

PLEASE NOTE:

Due to the nature of the KDSS, models fitted with KDSS may experience a 10-15mm lean resulting in the right hand side of the vehicle being lower. Part number TDUK-087 can be fitted to the top of the right rear coil which will assist with this issue.

Fitting sheet (located page 243) must be completed when suspension fitted. Failure to comply may affect warranty.



TOYOTA

LANDCRUISER - 200 SERIES

11/2007 ON



REAR SUSPENSION

ESTIMATED LIFT: 20mm

PART NO.	Qty	DESCRIPTION	NOTES
SHOCK ABSORBERS			
FC41114	2	Foam Cell Shock	Up To 20mm Lift
BM401114	2	40mm Adjustable Shock	
BMX1114/2	2	45mm Adjustable Shock	
TDR1114	2	'Ralph' Shock	
COIL SPRINGS			
TDC931SL	1	0-300KG Load (Pair)	OE Height
TDC931L	1	0-300KG Load (Pair)	
TDC931HL	1	CONSTANT 300KG Load (Pair)	20mm Lift
TDC931VHL	1	CONSTANT 500KG Load (Pair)	
PANHARD RODS			
TDPR-200	1	Adjustable Panhard Rod	
TDSB-006	1	33mm H/D Sway Bar Kit	Suit Non KDSS ONLY
AIR ASSIST BAGS			
TDAA-021	1	Coil Insert Bag Kit	Standard Height ONLY
TDAA-010	1	Coil Insert Bag Kit	Suit Up 25mm Lift
TDAA-011	1	Coil Insert Bag Kit	Suit Up 50mm Lift

REPLACEMENT BUSHINGS

PART NO.	Qty	DESCRIPTION	NOTES
QUANTITY PER SHOCK			
4WAY-001	1	Suit Front Bottom Eying	Eying Bonded Bushing
404454B	1	Suit Rear Top Of Top Pin	Pin Type Bushing
404454A	1	Suit Rear Bottom Of Top Pin	Pin Type Bushing
415024	1	Suit Rear Bottom Eying	Eying Bushing

PLEASE NOTE:

Fitment of Tough Dog upper control arms to vehicles that have lifts fitted greater than 50mm may suffer from premature ball joint failure due to longer droop lengths. The use of strut spacers may also effect the performance and longevity of the UCA ball joint due to the limitations of the spherical bearing housing being breached or bound at full suspension droop. There will be no warranty either expressed or implied if the vehicle is used out of legal driving conditions that will include but is not limited to jumping of the vehicle.



TOYOTA

PRADO - 95 SERIES

07/1996 - 2003



FRONT SUSPENSION

ESTIMATED LIFT: 40mm

PART NO.	Qty	DESCRIPTION	NOTES
SHOCK ABSORBERS			
FC404100	2	Foam Cell Strut	
BM404100	2	40mm Adjustable Strut	9 Stage Adjustable
COIL SPRINGS			
TDC971S	1	OE Height Spring (Pair)	
TDC971	1	40mm Lift Spring (Pair)	Petrol/Diesel/Bar
TDC971H	1	40mm Lift Spring (Pair)	Petrol/Diesel/Bar/Winch
COMPLETE STRUT ASSEMBLY			
1 Left Hand Side and 1 Right Hand Side strut assembly should be ordered			
TOY-095/01-LH	1	BM404100/TDC971	Bar Left Hand Side
TOY-095/01-RH	1	BM404100/TDC971	Bar Right Hand Side
TOY-095/02-LH	1	BM404100/TDC971H	Bar/Winch Left Hand Side
TOY-095/02-RH	1	BM404100/TDC971H	Bar/Winch Right Hand Side
TOY-095/03-LH	1	FC404100/TDC971	Bar Left Hand Side
TOY-095/03-RH	1	FC404100/TDC971	Bar Right Hand Side
TOY-095/04-LH	1	FC404100/TDC971H	Bar/Winch Left Hand Side
TOY-095/04-RH	1	FC404100/TDC971H	Bar/Winch Right Hand Side
TOY-095/05-LH	1	FC404100/TDC971S	OE Height Left Hand Side
TOY-095/05-RH	1	FC404100/TDC971S	OE Height Right Hand Side
TOY-095/06-LH	1	BM404100/TDC971S	Bar (OE Height) Left Hand Side
TOY-095/06-RH	1	BM404100/TDC971S	Bar (OE Height) Right Hand Side
ADDITIONAL COMPONENTS			
TOY-1081	2	Strut Top	Replacement Strut Top

Fitting sheet (located page 243) must be completed when suspension fitted. Failure to comply may affect warranty.



TOYOTA

PRADO - 95 SERIES

07/1996 - 2003



REAR SUSPENSION

ESTIMATED LIFT: 40mm

PART NO.	Qty	DESCRIPTION	NOTES
SHOCK ABSORBERS			
FC41108	2	Foam Cell Shock	OE Height
BM401108	2	40mm Adjustable Shock Shock	
FC41113	2	Foam Cell Shock	Suit 40mm Lift
BM401113	2	40mm Adjustable Shock	
COIL SPRINGS			
TDC973S	1	0-300KG Load (Pair)	25mm Lift
TDC973	1	0-300KG Load (Pair)	40mm Lift
TDC973H	1	CONSTANT 300KG Load (Pair)	40mm Lift

REPLACEMENT BUSHINGS

PART NO.	Qty	DESCRIPTION	NOTES
QUANTITY PER SHOCK			
ADJ300/40A	1	Suit Front Bottom Eying	Eying Bonded Bushing
TW959	2	Suit Rear Top Pin Mount	Pin Style Bushing
ADJ00191	1	Suit Rear Bottom Eying	Eying Bushing

All prices exclude freight. Include only permanent accessories & weights when selecting springs. Towing weight is not included.



FRONT SUSPENSION

ESTIMATED LIFT: 40mm

PART NO.	Qty	DESCRIPTION	NOTES
SHOCK ABSORBERS			
FC404400	2	Foam Cell Strut	
BM404400	2	40mm Adjustable Shock	9 Stage Adjustable
COIL SPRINGS			
TDC974S	1	OE Height Spring (Pair)	Petrol/Diesel/Bar
TDC974	1	40mm Lift Spring (Pair)	Petrol/Diesel/Bar
TDC974H	1	40mm Lift Spring (Pair)	Petrol/Diesel/Bar/Winch
COMPLETE STRUT ASSEMBLY			
1 Left Hand Side and 1 Right Hand Side strut assembly should be ordered			
TOY-120/01-LH	1	BM404400/TDC974	Bar Left Hand Side
TOY-120/01-RH	1	BM404400/TDC974	Bar Right Hand Side
TOY-120/02-LH	1	BM404400/TDC974H	Bar/Winch Left Hand Side
TOY-120/02-RH	1	BM404400/TDC974H	Bar/Winch Right Hand Side
TOY-120/03-LH	1	FC404400/TDC974	Bar Left Hand Side
TOY-120/03-RH	1	FC404400/TDC974	Bar Right Hand Side
TOY-120/04-LH	1	FC404400/TDC974H	Bar/Winch Left Hand Side
TOY-120/04-RH	1	FC404400/TDC974H	Bar/Winch Right Hand Side
TOY-120/07-LH	1	FC404400/TDC974S	Bar - OE Height Left Hand Side
TOY-120/07-RH	1	FC404400/TDC974S	Bar - OE Height Right Hand Side
TOY-120/08-LH	1	BM404400/TDC974S	Bar/Winch - OE Height Left Hand Side
TOY-120/08-RH	1	BM404400/TDC974S	Bar/Winch - OE Height Right Hand Side
ADDITIONAL COMPONENTS			
TOY-1084	2	Strut Top	Replacement Strut Top
TDSP-011	1	Swaybar Spacer Kit	76mm Hole Spacing
TDCA-005	1	Upper Control Arms (Pair)	Suit Up To 50mm Lift
TDSK-007	1	Bush Kit for TDCA-005	Replacement Bush Kit
TDSK-008	1	Ball Joint Kit for TDCA-005	Replacement Ball Joint

PLEASE NOTE:

Fitment of Tough Dog upper control arms to vehicles that have lifts fitted greater than 50mm may suffer from premature ball joint failure due to longer droop lengths. The use of strut spacers may also effect the performance and longevity of the UCA ball joint due to the limitations of the spherical bearing housing being breached or bound at full suspension droop. There will be no warranty either expressed or implied if the vehicle is used out of legal driving conditions that will include but is not limited to jumping of the vehicle.



REAR SUSPENSION

ESTIMATED LIFT: 40mm

PART NO.	Qty	DESCRIPTION	NOTES
SHOCK ABSORBERS			
FC41116	2	Foam Cell Chock	40mm Lift
BM401116	2	40mm Adjustable Shock	
COIL SPRINGS			
TDC975S	1	0-300KG Load (Pair)	OE Height - LWB
TDC975	1	0-300KG Load (Pair)	40mm Lift - LWB
TDC975H	1	CONSTANT 300KG Load (Pair)	
TDC975S	1	0-300KG Load (Pair)	40mm Lift - SWB
TDC975	1	CONSTANT 300KG Load (Pair)	
TDC975AB	1	0-300KG Load (Pair)	40mm Lift - Airbag Conversion
TDC975HAB	1	CONSTANT 300KG Load (Pair)	
AIR ASSIST BAGS - Coil Insert ONLY, does NOT suit OEM airbag replacement			
TDAA-009	1	Coil Insert Bag Kit	Suit Up To 40mm Lift
TDAA-020	1	Coil Insert Bag Kit	Suit Standard Height ONLY

REPLACEMENT BUSHINGS

PART NO.	Qty	DESCRIPTION	NOTES
QUANTITY PER SHOCK			
ADJ300/40A	1	Suit Front Bottom Eying	Eying Bonded Bushing
TW967	2	Suit Rear Top Pin Mount	Pin Style Bushing
415024	1	Suit Rear Bottom Eying	Eying Bushing

OEM AIRBAG VEHICLES

NOTES ON CONVERSION (Replacing Dampers Only)

The electronically controlled dampers on the 120 series Prado can be replaced with Tough Dog shock absorbers without error indicators appearing on the instrument cluster.

It is imperative that all Four shock absorbers are replaced at the same time.

If operating correctly, the electronically adjustable height control of the rear air springs will not be affected if all four dampers are replaced at the same time.

NOTES ON CONVERSION (Replacing Airbags & Dampers)

When converting from air springs to conventional coils at the rear of the Prado 120 series, the electronic workaround detailed in the instructions provided with the rear springs prevents the error indicator from being displayed in the instrument cluster.

The electronic workaround will also disable the electronic dampening system, it is therefore important that all four dampers be replaced if the air bag system is converted to coil springs.

Toyota Genuine Bump stop part number 48302-60080 spring seat sub assembly should be ordered through Toyota.



FRONT SUSPENSION

ESTIMATED LIFT: 40mm

PART NO.	Qty	DESCRIPTION	NOTES
SHOCK ABSORBERS			
FC404400	2	Foam Cell Strut	
BM404400	2	40mm Adjustable Shock	9 Stage Adjustable
COIL SPRINGS			
TDC974H	1	40mm Lift Spring (Pair)	Bar - LWB
TDC974HH	1	40mm Lift Spring (Pair)	Bar/Winch - LWB
TDC974S	1	40mm Lift Spring (Pair)	Bar - SWB
TDC974	1	40mm Lift Spring (Pair)	Bar/Winch - SWB
COMPLETE STRUT ASSEMBLY			
1 Left Hand Side and 1 Right Hand Side strut assembly should be ordered			
LWB			
TOY-150/03-LH	1	BM404400/TDC974H	Bar - LWB Left Hand Side
TOY-150/03-RH	1	BM404400/TDC974H	Bar - LWB Right Hand Side
TOY-150/04-LH	1	BM404400/TDC974HH	Bar/Winch - LWB Left Hand Side
TOY-150/04-RH	1	BM404400/TDC974HH	Bar/Winch - LWB Right Hand Side
TOY-150/07-LH	1	FC404400/TDC974H	Bar - LWB Left Hand Side
TOY-150/07-RH	1	FC404400/TDC974H	Bar - LWB Right Hand Side
TOY-150/08-LH	1	FC404400/TDC974HH	Bar/Winch - LWB Left Hand Side
TOY-150/08-RH	1	FC404400/TDC974HH	Bar/Winch - LWB Right Hand Side
SWB			
TOY-150/01-LH	1	BM404400/TDC974S	Bar - SWB Left Hand Side
TOY-150/01-RH	1	BM404400/TDC974S	Bar - SWB Right Hand Side
TOY-150/02-LH	1	BM404400/TDC974	Bar/Winch - SWB Left Hand Side
TOY-150/02-RH	1	BM404400/TDC974	Bar/Winch - SWB Right Hand Side
TOY-150/05-LH	1	FC404400/TDC974S	Bar - SWB Left Hand Side
TOY-150/05-RH	1	FC404400/TDC974S	Bar - SWB Right Hand Side
TOY-150/06-LH	1	FC404400/TDC974	Bar/Winch - SWB Left Hand Side
TOY-150/06-RH	1	FC404400/TDC974	Bar/Winch - SWB Right Hand Side
ADDITIONAL COMPONENTS			
TOY-1083	2	Strut Top	Replacement Strut Top
TDSP-012	1	Swaybar Spacer Kit	83mm Hole Spacing
TDCA-005	1	Upper Control Arms (Pair)	Suit Up To 50mm Lift
TDSK-007	1	Bush Kit for TDCA-005	Replacement Bush Kit
TDSK-008	1	Ball Joint Kit for TDCA-005	Replacement Ball Joint

Fitting sheet (located page 243) must be completed when suspension fitted. Failure to comply may affect warranty.



REAR SUSPENSION

ESTIMATED LIFT: 40mm

PART NO.	Qty	DESCRIPTION	NOTES
SHOCK ABSORBERS			
FC41118	2	Foam Cell Shock	40mm Lift
BM401118	2	40mm Adjustable Shock	
COIL SPRINGS			
TDC975S	1	0-300KG Load (Pair)	OE Height - LWB
TDC975	1	0-300KG Load (Pair)	40mm Lift - LWB
TDC975H	1	CONSTANT 300KG Load (Pair)	
TDC975S	1	0-300KG Load	40mm Lift - SWB
TDC975	1	CONSTANT 300KG Load	
AIR ASSIST BAGS			
TDAA-009	1	Coil Insert Bag Kit	Suit Up To 40mm Lift
TDAA-020	1	Coil Insert Bag Kit	Suit Standard Height ONLY

REPLACEMENT BUSHINGS

PART NO.	Qty	DESCRIPTION	NOTES
QUANTITY PER SHOCK			
ADJ300/40A	1	Suit Front Bottom Eying	Eying Bonded Bushing
TW967	2	Suit Rear Top Pin Mount	Pin Style Bushing
415024	1	Suit Rear Bottom Eying	Eying Bushing

PLEASE NOTE:

Fitment of Tough Dog upper control arms to vehicles that have lifts fitted greater than 50mm may suffer from premature ball joint failure due to longer droop lengths. The use of strut spacers may also effect the performance and longevity of the UCA ball joint due to the limitations of the spherical bearing housing being breached or bound at full suspension droop. There will be no warranty either expressed or implied if the vehicle is used out of legal driving conditions that will include but is not limited to jumping of the vehicle.



FRONT SUSPENSION

ESTIMATED LIFT: 40mm

PART NO.	Qty	DESCRIPTION	NOTES
SHOCK ABSORBERS			
FC404400	2	Foam Cell Strut	
BM404400	2	40mm Adjustable Strut	9 Stage Adjustable
COIL SPRINGS			
TDC974H	1	40mm Lift Spring (Pair)	Bar
TDC974HH	1	40mm Lift Spring (Pair)	Bar/Winch
COMPLETE STRUT ASSEMBLY			
1 Left Hand Side and 1 Right Hand Side strut assembly should be ordered			
TOY-150/03-LH	1	BM404400/TDC974H	Bar Left Hand Side
TOY-150/03-RH	1	BM404400/TDC974H	Bar Right Hand Side
TOY-150/04-LH	1	BM404400/TDC974HH	Bar/Winch Left Hand Side
TOY-150/04-RH	1	BM404400/TDC974HH	Bar/Winch Right Hand Side
TOY-150/07-LH	1	FC404400/TDC974H	Bar Left Hand Side
TOY-150/07-RH	1	FC404400/TDC974H	Bar Right Hand Side
TOY-150/08-LH	1	FC404400/TDC974HH	Bar/Winch Left Hand Side
TOY-150/08-RH	1	FC404400/TDC974HH	Bar/Winch Right Hand Side
ADDITIONAL COMPONENTS			
TOY-1083	2	Strut Top	Replacement Strut Top
TDCA-005	1	Upper Control Arms (Pair)	Suit Up To 50mm Lift
TDSK-007	1	Bush Kit for TDCA-005	Replacement Bush Kit
TDSK-008	1	Ball Joint Kit for TDCA-005	Replacement Ball Joint
TDSP-011	1	Swaybar Spacer Kit	76mm Spacing- 2006-2009 Vehicles
TDSP-012	1	Swaybar Spacer Kit	83mm Spacing - 2010 On Vehicles

PLEASE NOTE:

Fitment of Tough Dog upper control arms to vehicles that have lifts fitted greater than 50mm may suffer from premature ball joint failure due to longer droop lengths. The use of strut spacers may also effect the performance and longevity of the UCA ball joint due to the limitations of the spherical bearing housing being breached or bound at full suspension droop. There will be no warranty either expressed or implied if the vehicle is used out of legal driving conditions that will include but is not limited to jumping of the vehicle.



TOYOTA

FJ CRUISER

2011 - 2016



REAR SUSPENSION

ESTIMATED LIFT: 40mm

PART NO.	Qty	DESCRIPTION	NOTES
SHOCK ABSORBERS			
FC41116	2	Foam Cell Shock	40mm Lift
BM401116	2	40mm Adjustable Shock	
COIL SPRINGS			
TDC975	1	0-300KG Load (Pair)	40mm Lift
TDC975H	1	CONSTANT 300KG Load (Pair)	
AIR ASSIST BAGS			
TDAA-009	1	Coil Insert Bag Kit	Suit Up To 40mm Lift
TDAA-020	1	Coil Insert Bag Kit	Suit Standard Height Only

REPLACEMENT BUSHINGS

PART NO.	Qty	DESCRIPTION	NOTES
QUANTITY PER SHOCK			
ADJ300/40A	1	Suit Front Bottom Eying	Eying Bonded Bushing
TW967	2	Suit Rear Top Pin Mount	Pin Style Bushing
415024	1	Suit Rear Bottom Eying	Eying Bushing

All prices exclude freight. Include only permanent accessories & weights when selecting springs. Towing weight is not included.



TOYOTA

RAV4 - SXA, 10, 11

05/1994 - 2000



FRONT SUSPENSION

ESTIMATED LIFT: 30mm

PART NO.	Qty	DESCRIPTION	NOTES
SHOCK ABSORBERS			
BDS4001	2	Nitrogen Gas Strut Insert	Suit Up To 30mm Lift
COIL SPRINGS			
TDC981	1	30mm Lift Spring (Pair)	

REAR SUSPENSION

PART NO.	Qty	DESCRIPTION	NOTES
SHOCK ABSORBERS			
BD1106TB	2	Nitrogen Gas Shock	Suit Up To 30mm Lift
BM401106	2	40mm Adjustable Shock	
COIL SPRINGS			
TDC982	1	0-300KG Load	30mm Lift Spring

REPLACEMENT BUSHINGS

PART NO.	Qty	DESCRIPTION	NOTES
QUANTITY PER SHOCK			
TW959	2	Suit Rear Top Pin Mount	Pin Style Bushing
ADJ00191	1	Suit Rear Botton Eying	Eying Bushing

Fitting sheet (located page 243) must be completed when suspension fitted. Failure to comply may affect warranty.



TOYOTA

TUNDRA - UCK, UPK, USK 55, 56 03/2007 ON



FRONT SUSPENSION

ESTIMATED LIFT: 45mm

PART NO.	Qty	DESCRIPTION	NOTES
SHOCK ABSORBERS			
FC404910	2	Foam Cell Strut	Suit Up To 45mm Lift
BM404910	2	40mm Adjustable Strut	
COIL SPRINGS			
TDC930L	1	45mm Lift Spring (Pair)	Alloy Bar
TDC930HL	1	45mm Lift Spring (Pair)	Bar/Winch

REAR SUSPENSION

PART NO.	Qty	DESCRIPTION	NOTES
SHOCK ABSORBERS			
FC41117	2	Foam Cell Shock	Suit 45mm Lift
BM401117	2	40mm Adjustable Shock	
LEAF SPRINGS			
FS701	2	0-300KG Load	45mm Lift - Includes Bushing In Spring
ADDITIONAL COMPONENTS			
TDUK-074	1	Urethane Shackle Bushing Kit	Not Required When Ordering FS701
TDUK-076	1	Urethane Shackle Bushing Kit	Required For Lift Kit
TDUB-016HD	2	U-Bolt Kit	

All prices exclude freight. Include only permanent accessories & weights when selecting springs. Towing weight is not included.



FRONT SUSPENSION

ESTIMATED LIFT: 40mm

PART NO.	Qty	DESCRIPTION	NOTES
SHOCK ABSORBERS			
FC41382	2	Foam Cell Shock	Suit UAZ 452 (1965-1972)
BM401382	2	40mm Adjustable Shock	UAZ 469 (1972-1985) UAZ 3151 (1985-2003)
FC41391	2	Foam Cell Shock	Suit Hunter (2003 On)
BM401391	2	40mm Adjustable Shock	
FC41150	2	Foam Cell Shock	Suit Patriot (2005 On)
BM401150	2	40mm Adjustable Shock	
COIL SPRINGS			
TDC150SL	1	OE HEight Spring (Pair)	
TDC150L	1	40mm Lift Spring (Pair)	Bar
TDC150HL	1	40mm Lift Spring (Pair)	Bar/Winch

REAR SUSPENSION

PART NO.	Qty	DESCRIPTION	NOTES
SHOCK ABSORBERS			
FC41382	2	Foam Cell Shock	Suit UAZ 452 (1965-1972)
BM401382	2	40mm Adjustable Shock	UAZ 469 (1972-1985) UAZ 3151 (1985-2003)
FC41389	2	Foam Cell Shock	Suit Hunter (2003 On)
BM401389	2	40mm Adjustable Shock	
FC41389	2	Foam Cell Shock	Suit Patriot (2005 On)
BM401389	2	40mm Adjustable Shock	
LEAF SPRINGS			
FS160H	2	0-300KG Load	40mm Lift Spring
FS160HH	2	CONSTANT 400KG Load	40mm Lift Spring

Fitting sheet (located page 243) must be completed when suspension fitted. Failure to comply may affect warranty.



VOLKSWAGEN

AMAROK

2010 ON



FRONT SUSPENSION

ESTIMATED LIFT: 20mm

PART NO.	Qty	DESCRIPTION	NOTES
SHOCK ABSORBERS - SUIT TD SPRINGS ONLY			
FC404730	2	Foam Cell Strut	NOT Suitable With OE Coils
BM404730	2	40mm Adjustable Strut	
COIL SPRINGS - SUIT 2.0L ENGINE ONLY - ONLY SUITABLE WITH TD SHOCKS			
TDC110SL	1	OE Height Spring (Pair)	
TDC110L	1	20mm Lift Spring (Pair)	Bar
TDC110HL	1	20mm Lift Spring (Pair)	Bar/Winch
COIL SPRINGS - SUIT 3.0L V6 ENGINE ONLY - ONLY SUITABLE WITH TD SHOCKS			
TDC120L	2	20mm Lift Spring	Bar
TDC120HL	2	20mm Lift Spring	Bar/Winch

REAR SUSPENSION

PART NO.	Qty	DESCRIPTION	NOTES
SHOCK ABSORBERS			
FC41390	2	Foam Cell Shock	Up To 20mm Lift
BM401390	2	40mm Adjustable Shock	Up To 20mm Lift
LEAF SPRINGS			
FS710M	2	0-300KG Load	20mm Lift Spring
FS710HM	2	CONSTANT 300KG Load	20mm Lift Spring
ADDITIONAL COMPONENTS			
TDUK-072	1	Urethane Bushing Kit (Leaf)	Included in Kit Pricing
TDUK-075	1	Urethane Bushing Kit (Chassis)	Not included in Kit pricing - Order seperately if needed
Amarok chassis bush has two thicknesses - TDUK-075 includes both sizes. Please use correct set.			
TDUB-005	2	U-Bolt Kit	
AIR ASSIST BAGS			
TDAA-114	1	Bellows Bag Kit	Suit Up To 20mm Lift

All prices exclude freight. Include only permanent accessories & weights when selecting springs. Towing weight is not included.

Coilover setup can be complex - Please call (02) 9672 8899 to tailor a solution

PART NO.	QTY	RRP	DESCRIPTION	NOTES
SHOCK ABSORBERS				
BMX45305	2	12" Travel Shock (505/810mm)		
BMX45356	2	14" Travel Shock (565/910mm)		Includes Heim Joints
BMX45406	2	16" Travel Shock (610/1015mm)		
COIL SPRINGS				
TDC-BMX160	1	160lbs Spring		
TDC-BMX180	1	180lbs Spring		
TDC-BMX100	1	100lbs Tender Coil Spring		
TDC-BMX180T	1	180lbs Dual Rate (Tapered) Coil		One Piece Design - Tender Built In
<i>Custom Coil Design Available - Contact us on (02) 9672 8899</i>				
COMPONENTS				
TDUK-2000	1	Urethane Spring Connector		Urethane Seating Collar
TDUK-2001	1	Urethane Protector Sleeve		Protects Shock Body From Spring
361321	1	QA1 Heim Joints		Replacement Unit



QA1 Heim Joints



Urethane protector sleeve



100lbs tender coil



Urethane spring connector

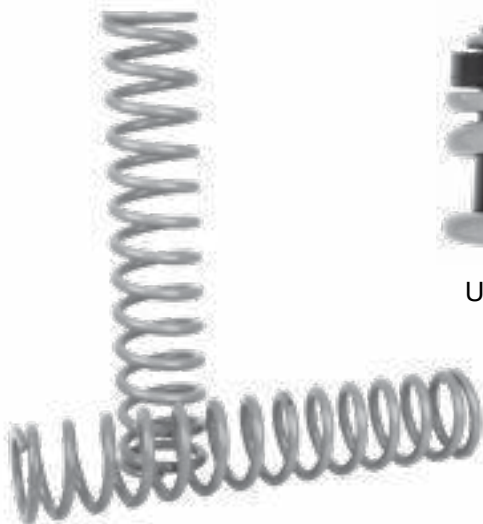

Coil springs



Dual Rate Tapered Coil Spring



Rock dog shock

Fitting sheet (located page 243) must be completed when suspension fitted. Failure to comply may affect warranty.

Please Complete this form for all warranty and part return requests. Returned items not accompanied by a form will experience extensive delays in processing

CUSTOMER DETAILS			
Fitted By:		Date	
Owner's Name		Year	
Address		Make	
Suburb	P'Code	Model	
Phone Number		Odometer:	
Email:		Comments:	

Measurements should be taken from the bottom of the rim to the wheel arch on each corner. In the case of a tray, measure to the same point each time

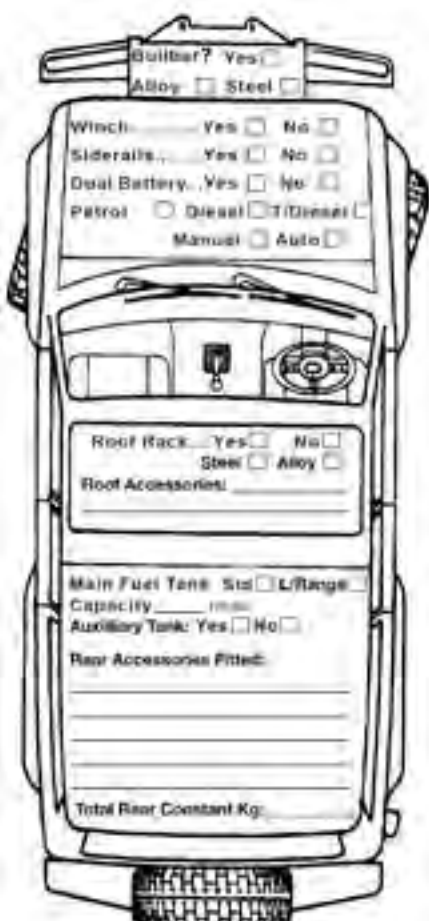
BEFORE & AFTER MEASUREMENTS	AFTERMARKET FITMENTS	BEFORE & AFTER MEASUREMENTS																												
<table border="1"> <thead> <tr> <th colspan="2">PASSENGER FRONT SIDE</th> </tr> </thead> <tbody> <tr><td>Original Height</td><td></td></tr> <tr><td>Height After Lift</td><td></td></tr> <tr><td>Height 500km Service</td><td></td></tr> <tr><td>Shock Fitted (P/N)</td><td></td></tr> <tr><td>Spring Fitted (P/N)</td><td></td></tr> <tr><td>Comments</td><td></td></tr> </tbody> </table>	PASSENGER FRONT SIDE		Original Height		Height After Lift		Height 500km Service		Shock Fitted (P/N)		Spring Fitted (P/N)		Comments			<table border="1"> <thead> <tr> <th colspan="2">DRIVERS FRONT SIDE</th> </tr> </thead> <tbody> <tr><td>Original Height</td><td></td></tr> <tr><td>Height After Lift</td><td></td></tr> <tr><td>Height 500km Service</td><td></td></tr> <tr><td>Shock Fitted (P/N)</td><td></td></tr> <tr><td>Spring Fitted (P/N)</td><td></td></tr> <tr><td>Comments</td><td></td></tr> </tbody> </table>	DRIVERS FRONT SIDE		Original Height		Height After Lift		Height 500km Service		Shock Fitted (P/N)		Spring Fitted (P/N)		Comments	
PASSENGER FRONT SIDE																														
Original Height																														
Height After Lift																														
Height 500km Service																														
Shock Fitted (P/N)																														
Spring Fitted (P/N)																														
Comments																														
DRIVERS FRONT SIDE																														
Original Height																														
Height After Lift																														
Height 500km Service																														
Shock Fitted (P/N)																														
Spring Fitted (P/N)																														
Comments																														
<table border="1"> <thead> <tr> <th colspan="2">PASSENGER REAR SIDE</th> </tr> </thead> <tbody> <tr><td>Original Height</td><td></td></tr> <tr><td>Height After Lift</td><td></td></tr> <tr><td>Height 500km Service</td><td></td></tr> <tr><td>Shock Fitted (P/N)</td><td></td></tr> <tr><td>Spring Fitted (P/N)</td><td></td></tr> <tr><td>Comments</td><td></td></tr> </tbody> </table>	PASSENGER REAR SIDE		Original Height		Height After Lift		Height 500km Service		Shock Fitted (P/N)		Spring Fitted (P/N)		Comments			<table border="1"> <thead> <tr> <th colspan="2">DRIVERS REAR SIDE</th> </tr> </thead> <tbody> <tr><td>Original Height</td><td></td></tr> <tr><td>Height After Lift</td><td></td></tr> <tr><td>Height 500km Service</td><td></td></tr> <tr><td>Shock Fitted (P/N)</td><td></td></tr> <tr><td>Spring Fitted (P/N)</td><td></td></tr> <tr><td>Comments</td><td></td></tr> </tbody> </table>	DRIVERS REAR SIDE		Original Height		Height After Lift		Height 500km Service		Shock Fitted (P/N)		Spring Fitted (P/N)		Comments	
PASSENGER REAR SIDE																														
Original Height																														
Height After Lift																														
Height 500km Service																														
Shock Fitted (P/N)																														
Spring Fitted (P/N)																														
Comments																														
DRIVERS REAR SIDE																														
Original Height																														
Height After Lift																														
Height 500km Service																														
Shock Fitted (P/N)																														
Spring Fitted (P/N)																														
Comments																														

CLAIMS FORM

WARRANTY & RETURNS

Please Complete this form for all warranty and part return requests. Returned items not accompanied by a form will experience extensive delays in processing

CUSTOMER DETAILS				
Name:				
Address:				
Suburb:		Postcode:		
PURCHASE DETAILS				
Dealer Name:				
Purchase Date:		Invoice No:		
VEHICLE DETAILS				
Year:		Make		Model:

ITEMS FOR WARRANTY/RETURN

PART NO.	QTY	REASON FOR RETURN	CREDIT AC.	REPLACE ITEM

Fitting sheet (located page 243) must be completed when suspension fitted. Failure to comply may affect warranty.



DISCLAIMER FORM

VEHICLES LIFTED MORE THAN 50MM

Vehicles fitted with a lift kit greater than 50mm over Original Equipment height may require additional certification to remain fit for registered use. Consult with your dealer on the steps to obtain engineering certification in your state / territory.

CUSTOMER DETAILS			
Rego No:			Date
Owner's Name			Year
Address			Make
Suburb		P'Code	Model
Phone Number			Odometer:
Email:			Comments:

Declaration

The suspension components fitted to this vehicle (Registration _____) are designed to lift the vehicle by more than 50mm. Vehicles with lifts greater than 50mm may require engineer's approval to continue to be used as a road-registered vehicle. Information on the certification process differs by jurisdiction.

Ensuring continuing compliance with the requirements of registration is the responsibility of the owner or operator of the vehicle and no liability shall be accepted by any other person. Compliance of the vehicle may be undertaken with the assistance of a qualified certifying engineer, at the expense of the vehicle owner.

Schedule of Parts Fitted		
	FRONT	REAR
Shock Absorbers		
Coil Springs		
Steering Stabilizer		
Panhard Rods		
Castor Bushes/ Plates		
Transmission Spacers		
Brake Hoses		

In most states, engineering certification requires that the entire vehicle be presented in a roadworthy condition. The final approval on any vehicle is at the discretion of the certifying engineer and that state or territory's registration authority.

By purchasing this equipment, the buyer acknowledges that additional steps may be required, and that 4 Way Suspension Products shall not be held responsible for the continued compliance of the vehicle.

Signed: _____ Date: _____

Name (Print): _____

Disclaimer

4Way Suspension Products Pty Ltd markets a range of off road products that may require certification from a qualified engineer prior to driving on public roads. The fitment of these items and the operation of the vehicle on public roads or road related areas prior to certification may render the vehicle unroadworthy, and may affect the status of your registration. Please check with the relevant ADR authorities in your state or territory and a qualified engineer. Details of suitable engineers are provided by the state/territory authority.

All prices exclude freight. Include only permanent accessories & weights when selecting springs. Towing weight is not included.





PURCHASE ORDER FORM

Please Complete this form for all warranty and part return requests. Returned items not accompanied by a form will experience extensive delays in processing

CUSTOMER DETAILS						
Name:				Date:		
ABN No				Staff Member:		
Address:				Phone Number		
				Fax Number:		
Suburb		P'Code:		Email		
SHIPPING DETAILS - Note: Must be a Business Address - NO DROP SHIPPING						
Address				Order Number:		
				Freight Service:	Standard	Air / Express
Freight (circle)	4WAY Default	Other (specify):		Freight A/C No:		
Send order by email to sales@4waysuspension.com.au						

Fitting sheet (located page 243) must be completed when suspension fitted. Failure to comply may affect warranty.



THIS PAGE IS INTENTIONALLY BLANK

All prices exclude freight. Include only permanent accessories & weights when selecting springs. Towing weight is not included.